

Cerwin

THE QUALITY OF EXPERIENCE



THE QUALITY OF EXPERIENCE

Die Firma **CERIN** begann mit ihren Aktivitäten im Jahre 1971 und ist heute eines der bestbekanntesten und solidesten **italienischen Unternehmen im Bereich Hartmetall-Präzisionswerkzeuge**.

Im Laufe der Jahre hat sich die Firma **CERIN** zu einem Branchenführer entwickelt und konnte sich auf den weltweiten Märkten behaupten durch ihre Produktqualität, Leistungsfähigkeit und Flexibilität der internen Strukturen. Außerdem bewährte sich ihr starkes Entwicklungs- und Forschungsengagement, das sich am Entwurf neuer Produkte orientiert.

Um die Wünsche und Anforderungen unserer Kunden zu erfüllen, steht ein technischer- und kaufmännischer Beratungsdienst immer zur Verfügung.

Die Firma **CERIN** ist zertifiziert nach Norm UNI EN ISO 9001:2008.

*CERIN has been present on the market since 1971 and currently represents one of the most well known and well reputed **Italian manufacturer of carbide precision tools**.*

During the years CERIN has become leader in the field and have been known on the domestic and international markets as high quality manufacturer thanks, above all, to the constant commitment focused to the main purpose: total customer's satisfaction pursued through: Quality of the Products, Efficiency of the inner structure, Services available for the clientele and Research and Development engaged in new products development.

A service of technical and commercial assistance is always available to meet customer needs.

The company is UNI EN ISO 9001:2008 certified.



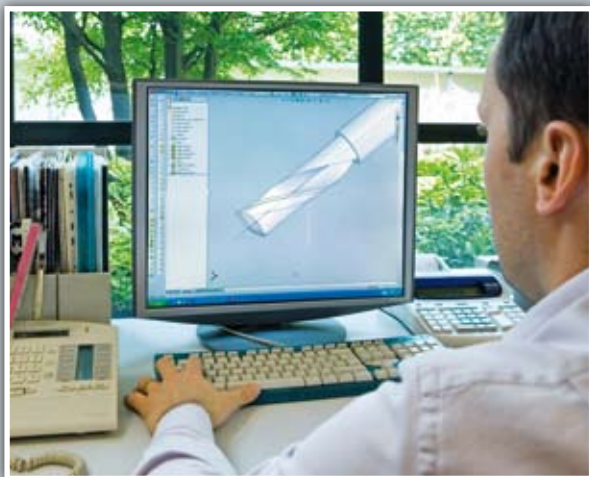



Seite
Page 06

Einführung
Introduction

Seite
Page 31

Frässtifte
Rotary burs

01

Seite
Page 67

VHM-Schaftfräser
End mills

02

Seite
Page 227

Bohrwerkzeuge
Drills

03

Seite
Page 267

Reibahlen
Reamers

04

Seite
Page 281

Kegelsenker
Countersinks

05

0916

Hartmetallqualitäten - Anwendungsbereiche und -Sorten Carbide features - Field of applications and grades

Stahlwerkstoffe HM-Sorte	Rostfreie Stähle HM-Sorte	Gußwerkstoffe HM-Sorte	gehärtete Stähle HM-Sorte	Einsatzverhalten	
				Härte	Zähigkeit
Steels Carbide grade	Stainless steels Carbide grade	Cast irons Carbide grade	Hardened steels Carbide grade	Properties Hardness Toughness	
P01 - P05	M01 - M05	K01 - K05	H01 - H05	↑↑	↓↓
P10 - P15	M10 - M15	K10 - K15	H10 - H15		
P20 - P25	M20 - M25	K20 - K25	H20 - H25	↑↑	↓↓
P30 - P35	M30 - M35	K30 - K35	H30		
P40 - P45	M40	K40			
P50					

Fein- und Feinstkorn Hartmetalle mit WC/Co Gefüge sind für fast alle Zerspanungsaufgaben bestens geeignet. Durch die enorme Härte und gute Biegefestigkeit können bei bester Standzeit höhere Schnittgeschwindigkeiten und Vorschübe als bei herkömmlichen Hartmetallen gefahren werden. Durch das Feinkorngefüge sind auch bessere Oberflächen und Schneidenschärfe erreichbar.

Tungstencarbide/Cobalt structured hard metals of fine and extra fine grain are suited at best for almost all cutting tasks. By means of extraordinary hardness and good flexural strength «with longest tool life» higher cutting speeds and feeds can be driven as with conventional carbides. Also better surfaces and sharpness of cutting edges can be attained by the use of fine grain structured carbides.

Korngrößen der Mikron und Submikron Bereiche Grain size range of micron and submicron grades

Gängige Bezeichnung Description	WC-Kristalle Korngröße (µm) Carbide grain size (µm)
Nano Feinstkorn Nano fine grain	< 0,2 (=200nm)
Ultrafeinstkorn Ultrafine grain	0,2 - 0,5
Feinstkorn Micro grain	0,5 - 0,8
Feinkorn Fine grain	0,8 - 1,3
Mittelkorn Medium grain	1,3 - 2,5
Grossekorn Coarse grain	2,5 - 6,0
Grosserkorn Extra coarse grain	> 6,0

Cerin Standard-Hartmetall-Qualitäten Cerin standard carbide grades

Hartmetall-Qualitäten Cerin carbide grade	Hartmetall-Qualitäten Carbide grade	Hartmetall - Eigenschaften Carbide properties
CK 05-10 MG	K05	Feinkorn mit ≤ 6% Co - für Diamantbeschichtung geeignet <i>Fine grain with ≤ 6% Co suitable for diamond coating</i>
CK 10-20 MG	K10-K20	Feinkorn Universalqualität - gute Härte und Zähigkeit <i>Fine grain for common use - Good hardness and toughness</i>
CK 20-30 MG	K20-K30	Feinkorn - Universalqualität - gute Härte und Biegefestigkeit <i>Fine grain for common use - Good hardness and bending strength</i>
CK 30 M	K30	Standard Guß-Qualität - gute Härte - für kurzspanige Werkstoffe <i>Standard cast iron grade - Good hardness - Short chipping materials</i>
CK 10-30UF	K10-K30	Feinstkorn für Werkstoffe ≤ 67 HRC - <i>Superfine grain for materials ≤ 67 HRC -</i>

Beschichtungstemperaturen / Hartstoff - Verschleißschutz- und Gleitschichten Coating temperatures / Wear protection and anti-friction coatings for hard materials

Kurzbezeichnung <i>Short term</i>	Prozess-Temperatur <i>Process-Temperature</i>	Anwendungsbereich <i>Range of applications</i>
PVD - physikalische Gasabscheidung <i>PVD - Physical Vapour Deposition</i>	200° - 550°	VHM-Zerspanungswerkzeuge <i>Carbide cutting tools</i>
CVD - chemische Gasabscheidung <i>CVD - Chemical Vapour Deposition</i>	400° - 800°	Geschliffene Wendeplatten <i>Ground inserts</i>
■ MT/HT-CVD - Mittel und hoch Temperatur CVD ■ <i>MT/HT-CVD - Medium/High temperature CVD</i>	700° - 1100°	Wendeschnidplatten <i>Inserts</i>

■ Durch die hohe Prozess-Temperatur besteht die Gefahr einer Versprödung der Werkzeugschneiden

■ *Due to high process temperatures there is a risk of embrittlement of cutting edges*

Standard Beschichtungen und Anwendungen Standard coatings and range of applications

Bezeichnung <i>Description</i>	Beschichtungsart <i>Coating Class</i>	Zusammen- setzung <i>Composition</i>	Schichtaufbau <i>Coating Structure</i>	Micro Härte HV 0,05 <i>Micro Hardness HV 0,05</i>	Maximale Einsatz- temperatur <i>Maximum application temperature °C</i>	Reib- Beiwert gegen Stahl <i>Friction coefficient against steel</i>	Schicht- dicke (µm). <i>Coating Thickness (µm)</i>	
A	Cer-T	Supernitride	TIALN	Monolayer	3500	900	0,4	2-4
B	Cer-X	Supernitride	TIALN	Monolayer	2700	900	0,5	2-5
C	Cer-A	Supernitride	TIALN	Monolayer	2700	900	0,5	2-5
D	Cer-D	Diamond	SP3	Monolayer	10000	600	0,05	6-8
E	Cer-P	Borid	TIB2	Monolayer	3500	900	0,4	1-3
F	Cer-Drl	Supernitride	TIALCN	Multilayer	3200	600	0,25	2-5
G	Cer-Al	Borid	TIB2	Monolayer	3500	900	0,4	1-3
H	Cer-H	Supernitride	TIALN	Monolayer	2700	900	0,5	2-5
U	Cer-CrN	Hard mat.	TiN	Monolayer	2500	520	0,4	2-5
V	Cer-TiCN	Hard mat.	TiCN	Multilayer	3000	420	0,3	2-5
Z	Cer-TiN	Hard mat.	TIALCN	Multilayer	3200	600	0,25	2-5

Werkstück-Werkstoff - Vergleich nach Zugfestigkeit und Härte Workpiece materials - Comparison of tensile strength and hardness

N/mm ²	HRC	HB	Hv10
≤ 255		≤ 76	≤ 80
≤ 400		≤ 119	≤ 125
≤ 705		≤ 209	≤ 220
≤ 850	≤ 24,8	≤ 252	≤ 265
≤ 1125	≤ 35,5	≤ 333	≤ 350
≤ 1420	≤ 44,5	≤ 418	≤ 440
≤ 1630	≤ 49,1	≤ 475	≤ 500
≤ 2030	≤ 55,7	≤ 580	≤ 610
	46,1 - 60,1		437 - 700
	48,4 - 63,3		490 - 780
	54,1 - 66,4		580 - 880

Empfehlung für VHM- Werkzeugeinsatz, mit und ohne Beschichtung Recommendation for use of carbide tools with and without coating

N/mm ²	HRC	Frässtifte Rotary burs	Schaftfräser End mills	Bohrer Drills	Reibahlen Reamers	Senker Countersinks
≤ 255		◇	◇	◇	◇	◇
≤ 400		◇	◇	◇	◇	◇
≤ 705		◇	□	□	◇	◇
≤ 850	≤ 24,8	◇	□	□	□	◇
≤ 1125	≤ 35,5	◇	□	□	□	◇
≤ 1420	≤ 44,5	□	▲	□	□	□
≤ 1630	≤ 49,1	□	▲	□	□	□
≤ 2030	≤ 55,7	□	▲	▲	▲	▲
	46,1 - 60,1	□	▲	▲	▲	▲
	48,4 - 63,3	▲	▲	▲	▲	▲
	54,1 - 66,4	▲	▲	▲	▲	▲

◇ Unbeschichtet / Uncoated □ mit und ohne Beschichtung / with and without coating ▲ nur mit Beschichtung / with coating only

Beschichtete VHM-Werkzeuge haben einen geringeren Reibwert als blanke Werkzeuge.

In der Serienfertigung sind mit beschichteten Werkzeugen, durch höhere Schnittparameter, bei längeren Standzeiten, deutliche Kostenreduzierungen möglich.

Coated carbide tools do have minor friction coefficient than uncoated tools.

In series production significant cost reductions are possible by using coated tools with higher cutting parameters.

Cerin fertigt Vollhartmetallwerkzeuge für fast alle zerspanbaren Werkstoffe
Cerin manufacture solid carbide tools for almost all kind of machinable materials

Farbkennung der verschiedenen Werkstück-Werkstoffgruppen
Colour code for different groups of workpiece - materials

Gruppe Group A	Aluminium - Aluminium Legierungen - MMC faserverstärkte Leichtmetalllegierungen Alu Knetlegierungen - Alu Gusslegierungen Kupfer - Kupferlegierungen - Messing - Bronze Magnesium - Magnesium Knet- und Gusslegierungen
	<i>Aluminium - Aluminium alloys - MMC Reinforced fibres light metal alloys</i> <i>Wrought aluminium alloys - Cast aluminium alloys</i> <i>Copper - Copper alloys - Brass - Bronze</i> <i>Magnesium - Magnesium wrought and cast alloys</i>
Gruppe Group B	Kunststoffe - Polycarbonate - Plexiglas - GFK - CFK -AFK - Duroplaste - Thermoplaste Hartholz - Hartgummi - NE-Materialien - Presskarton
	<i>Plastics - Polycarbonate - Plexiglass - GFK - CFK - AFK - Thermosets - Thermoplastics</i> <i>Hard wood - Hard rubber - Nonferrous materials - Pressed carton</i>
Gruppe Group C	Weicheisen - Baustähle - Automatenstähle - Legierte Stähle - Nitrierstähle Werkzeugstähle - Sonder-Stahlwerkstoffe - gehärtete Stähle -
	<i>Soft iron - Construction steel - Machine steel - Alloyed steel - Nitrided steel</i> <i>Tool steels - Special steels - Hardened steels</i>
Gruppe Group D	Rost u. säurebeständige Stähle -Hitzebeständige Stähle Edelstähle
	<i>Corrosion and acid resistant steels - Heat-resistant steels</i> <i>Stainless steel</i>
Gruppe Group E	Nickel/Kobalt Legierungen Rein Titan - Titan Legierungen
	<i>Nickel/Cobalt alloys</i> <i>Titanium - Titanium alloys</i>
Gruppe Group F	Gusseisen - Temperguss - Hartguss Gusseisen mit Kugel- und Vermikulargraphit
	<i>Cast irons - Malleable cast irons - Hard cast iron</i> <i>Graphite for electrodes</i>
Gruppe Group G	Wolfram-Kupferlegierungen für Elektroden Graphit für Elektroden
	<i>Tungsten-copper alloys for electrodes</i> <i>Graphite for electrodes</i>

Sollte ein von Ihnen zu bearbeitender Werkstoff nicht aufgelistet sein, fragen Sie bei uns an.
If any type of material processed by you is not listed, please contact us.

Schaftausführungen (für Bohr- und Fräswerkzeuge) DIN 6535

Shank design (for drilling and milling tools) DIN 6535

glatter Zylinderschaft- Form HA

Straight cylindrical shank - Shape HA

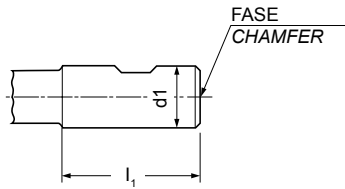

d_1	l_1	d_1	l_1	d_1	l_1
h6	+2	h6	+2	h6	+2
	0		0		0
2	28	8	36	18	48
3	28	10	40	20	50
4	28	12	45	25	56
5	28	14	45	32	60
6	36	16	48		

Zylinderschaft - Form HB

Cylindrical shank - Shape HB

eine Mitnahmefläche - $d_1 = 6$ bis 20 mm
one Weldon flat - $d_1 = 6$ to 20 mm

zwei Mitnahmeflächen - $d_1 = 25$ bis 32 mm
two Weldon flats - $d_1 = 25$ to 32 mm

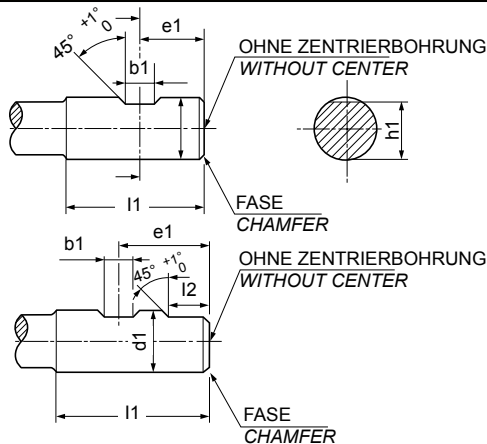

d_1	b_1	e_1	h_1	l_1	l_2
h6	+0,05	0	h11	+2	+1
	0	-1	0	0	0
6	4,2	18	5,1	36	
8	5,5	18	6,9	36	
10	7	20	8,5	40	
12	8	22,5	10,4	45	
14	8	22,5	12,7	45	
16	10	24	14,2	48	
18	10	24	16,2	48	
20	11	25	18,2	50	
25	12	32	23	56	17
32	14	36	32	60	19

Zylinderschaft - Form HE

Cylindrical shank - Shape HE

eine geneigte Spannfläche - $d_1 = 6$ bis 20 mm
one slope flat - $d_1 = 6$ to 20 mm

eine geneigte Spannfläche - $d_1 = 25$ bis 32 mm
one slope flat - $d_1 = 25$ to 32 mm

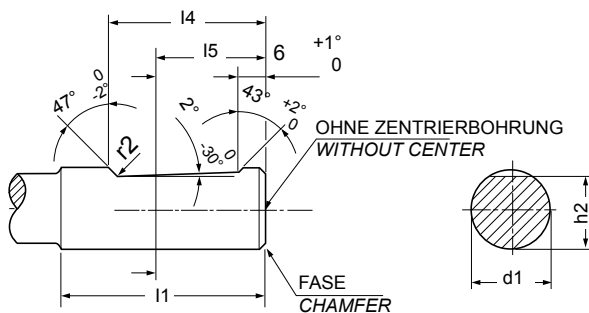

d_1	(b_2)	(b_3)	h_2	(h_3)	l_1	l_4	l_5	r_2
h6			h11		+2	0	Nenn- maß	min.
			0		0	-1		
6	4,3		5,1		36	25	18	1,2
8	5,5		6,9		36	25	18	1,2
10	7,1		8,5		40	28	20	1,2
12	8,2		10,4		45	33	22,5	1,2
14	8,1		12,7		45	33	22,5	1,2
16	10,1		14,2		48	36	24	1,6
18	10,8		16,2		48	36	24	1,6
20	11,4		18,2		50	38	25	1,6
25	13,8	9,3	23,0	24,1	56	44	32	1,6
32	15,5	9,9	30,0	31,2	60	48	35	1,6

Nennmass
Nominal size

Schaftausführung (für Bohr- und Fräswerkzeuge) ähnlich DIN 6535
Shank design (for drilling and milling tools) similar to DIN 6535

Zylinderschaft - Form HEK
Cylindrical shank - Shape HEK

eine geneigte Spannfläche - $d_1 = 6$ bis 20 mm
one slope flat - $d_1 = 6$ to 20 mm

eine geneigte Spannfläche - $d_1 = 25$ bis 32 mm
one slope flat - $d_1 = 25$ to 32 mm

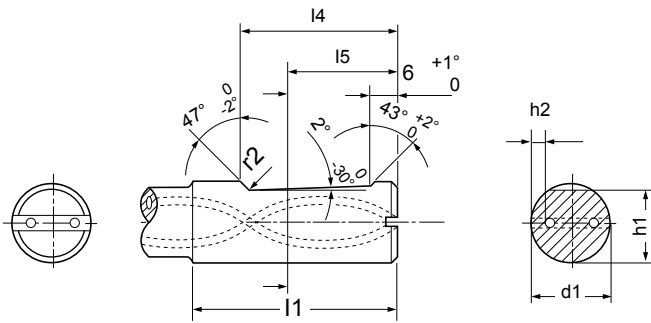

d_1	l_1	l_4	l_5	h_1	r_2	h_2
h6	+2	0	Nenn- maß	h11		min.
0	0	-1				
6	36	25	18	5,3	1,2	1,3
8	36	25	18	7,1	1,2	1,5
10	40	28	20	8,9	1,2	1,8
12	45	33	22,5	10,9	1,2	2,0
14	45	33	22,5	12,4	1,2	2,5
16	48	36	24	14,5	1,6	2,5
18	48	36	24	16,2	1,6	2,8
20	50	38	25	18,2	1,6	3
25	56	44	32	23	1,6	3,7
32	60	48	35	30	1,6	4,5

Nennmass
 Nominal size

Schaftausführung mit Mitnehmer DIN 1809
Shank with drive tenon DIN 1809

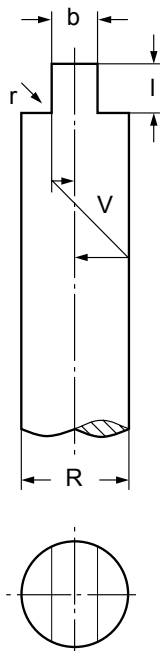

d_1		b	l	r	v
von/from	bis/up to	h12	$\pm IT16^1$		
3	3,5	1,6	2,2	0,2	0,05
3,5	4	2	2,2	0,2	0,05
4	4,5	2,2	2,5	0,2	0,05
4,5	5,5	2,5	2,5	0,2	0,05
5,5	6,5	3	3	0,2	0,05
6,5	8	3,5	3,5	0,2	0,06
8	9,5	4,5	4,5	0,4	0,06
9,5	11	5	5	0,4	0,06
11	13	6	6	0,4	0,06
13	15	7	7	0,4	0,08
15	18	8	8	0,4	0,08
18	21	10	10	0,4	0,08
21	24	11	11	0,6	0,10
24	27	13	13	0,6	0,10
27	30	14	14	0,6	0,10
30	34	16	16	0,6	0,10
34	38	18	18	0,6	0,10
38	42	20	19	0,6	0,15
42	46	22	20	1,0	0,15
46	50	24	22	1,0	0,15



**Einsatzgebiete
Materialgruppen**

***Range of application
Material groups***

**Ausklappseite
*Fold-out page***

Werkstückwerkstoffe / Materials

Gruppe Group		Werkstoff Materials	Festigkeit N/mm ² Strength N/mm ²	
Leichtmetalle Light Alloys	Aluminium - Aluminium Knetlegierungen - Alu Gußlegierungen / Aluminium - Wrought aluminium alloys - Cast aluminium alloys			
	A 1	A 1.1	Alu Gußlegierungen <5% Si / Cast aluminium alloys <5% Si	≤ 255
		A 1.2	Alu Knetlegierungen / Wrought aluminium alloys	≤ 255
		A 1.3	Alu Gußlegierungen > 12% <Si / Cast aluminium alloys <12% Si	≤ 255
		A 1.4	Alu Gußlegierungen >5% <12% / Cast aluminium alloys >5 % <12%	≤ 400
		A 1.5	Alu Gußlegierungen >5% <12% / Cast aluminium alloys >5 % <12%	≤ 400
		A 1.6	Alu Knetlegierungen / Wrought aluminium alloys	≤ 705
		A 1.7	Faserverstärkte LM Legierungen / Reinforced aluminium alloys	≤ 705
	A 2	Kupfer - Kupfer Legierungen - Messing - Bronze / Cooper - Cooper alloys - Brass - Bronze		
		A 2.1	Rein- und niedriglegiertes Kupfer / Low alloys cooper	≤ 400
		A 2.2	Kupfer Zinn Legierung / Cu-Sn alloys (cooper)	≤ 400
		A 2.3	Bronze kurzspanend / Cu-Sn alloys (cooper)	≤ 400
		A 2.4	Kupfer-Zink Legierungen / Cu-Zn alloys (brass) (long chipping)	≤ 705
		A 2.5	Messing kurzspanend / Cu-Zn alloys (brass) (short chipping)	≤ 705
A 2.6		Messing langspanend / Cu-Zn alloys (brass) (long chipping)	≤ 705	
A 2.7	Kupfer-Alu Legierung/Alubronze / Cu-Sn alloys (bronze)	≤ 850		
A 3	Kupfer Sonderlegierungen / Cooper special alloys			
	A 3.1	Kupfer Sonderlegierungen bis Q18 / Cooper special alloys from Q18	≤ 705	
A 3.2	Kupfer Sonderlegierungen über Q18 / Cooper special alloys	≤ 705		
A 4	Magnesium Legierungen - Magnesium Gußlegierungen / Magnesium alloys - Cast magnesium alloys			
	A 4.1	Magnesium Knetlegierungen / Magnesium wrought alloys	≤ 705	
	A 4.2	Magnesium Gußlegierungen / Cast magnesium alloys	≤ 705	
Kunststoffe und Verbundwerkstoffe Plastic & Comp. Materials	Kunststoffe - kurz- und langspanend / Plastics - short and long chipping			
	B 1	B 1.1	Duroplaste kurzspanend / Duroplaste short chipping	110
		B 1.2	Thermoplaste langspanend / Thermoplaste long chipping	80
		B 1.3	Polykarbonate / Polycarbonate	110
		B 1.4	Faserverstärkte Kunststoffe / Reinforced Plastics Fibers	800-1500
		B 1.5	Plexiglas / Plexiglass	130
		B 1.6	Kevlar / Kevlar	110
	B 2	NE Werkstoffe - Sonderwerkstoffe / Nonferrous metals - Special plastic		
		B 2.1	Hartholz / Hardwood	< 80
		B 2.2	Hartgummi / Hard rubber	< 80
		B 2.3	NE-Metalle / Nonferrous metals	< 80
		B 2.4	Presskarton / Pressed carton	< 80
		Allgemeine Stähle - Baustähle - Legierte Stähle / Structural Steel		
		C 1	C 1.1	Kaltfließpresssäthle / Materials for rail vehicles
C 1.2			Magnetweicheisen / Soft magnetic material	≤ 400
C 1.3	Automatenstähle / Automatic steel		≤ 705	
C 1.4	Allgemeine Baustähle / Structural steel (unalloyed, warm-rolled)		≤ 705	
C 1.5	Einsatzstähle / Hardened steel (unalloyed/alloyed)		≤ 705	
C 1.6	Vergütungsstähle / Heat-treatable steel (special steel)		≤ 850	
C 1.7	Legierte Stähle Stahlguß / Cold upsetting and cold extrusion steel, heat-treatable steel		≤ 1125	
C 1.8	Automatenstähle Baustähle / Structural steel (unalloyed, warm-rolled)		≤ 1125	
C 2	Nitrierstähle Kalt- und Warmarbeitsstähle / Roller bearing steel - Tool steel for warm working			
	C 2.1	Nitrierstähle / Roller bearing steel	≤ 1125	
	C 2.2	Kaltarbeitsstähle / Tool steel for cold working (alloyed)	≤ 1125	
	C 2.3	Warmarbeitsstähle / Tool steel for warm working	≤ 1125	
	C 2.4	Vergütungsstähle Nitrierstähle / Cast steel for flame and induction hardening	≤ 1420	
C 3	Gehärtete Stähle / Tool Steel for warm working			
	C 3.1	Gehärtete Stähle / Tool steel for warm working	< 44,5HRc	
	C 3.2	Gehärtete Stähle / Tool steel for warm- and cold-working	44 - 56 HRc	
	C 3.3	Gehärtete Stähle / Tool steel for warm- and cold-working	56 - 60 HRc	
	C 3.4	Gehärtete Stähle / Tool steel for cold working (alloyed)	58 - 63 HRc	
	C 3.5	Gehärtete Stähle / Tool steel for cold working (alloyed)	56 - 67 HRc	
C 4	Sonder Stahl-Werkstoffe / Special Steel			
	C 4.1	Stahl Sonderwerkstoffe / Specialsteel	≤ 1125	
C 4.2	Stahl Sonderwerkstoffe / Specialsteel	≤ 1420		
Rostfreier Stahl Stainless Steel	Rost- Säure- und Hitzebeständige Stähle / Heat-resistant steel - Stainless austenitic steel			
	D 1	D 1.1	Rostbeständige Stähle / Heat-resistant steel	≤ 850
		D 1.2	Rostbeständige Stähle / Heat-resistant steel	≤ 850
		D 1.3	Hitzebeständige Stähle / Austenitic stainless steel	≤ 850
		D 1.4	Rost- Säure- Hitzebeständige Stähle / Valve materials (heat-resistant)	≤ 1125
		D 1.5	Rost- Säure- Hitzebeständige Stähle / High heat-resistant steel and alloys	≤ 1420
Titan - Titanlegierungen / Titanium and Titanium alloys				
E 1	E 1.1	Reintitan / Titanium (pure)	≤ 705	
	E 1.2	Titanlegierungen / Wrought titanium alloy	≤ 1125	
	E 1.3	Titanlegierungen Wrought titanium alloy	≤ 1420	
E 2	Nickel/Kobaltlegierungen / Wrought nickel-copper alloy			
	E 2.1	Nickel-/Kobaltlegierungen warmfest / Wrought nickel-copper alloy	≤ 705	
	E 2.2	Nickel/Kobaltlegierungen hochwarmfest / Wrought nickel-chrome alloy	≤ 1420	
E 2.3	Nickel/Kobaltlegierungen hochwarmfest / Wrought nickel-chrome alloy	≤ 2030		
Gußeisen Cast Irons	Grau- Hart- und Temperguß / Grey and hard cast iron			
	F 1	F 1.1	Grauguß GG 20 / Grey cast iron	< 333 HB
		F 1.2	Grauguß GG 30 / Grey cast iron	< 333 HB
		F 1.3	Hartguß / Hard cast iron	≤ 416 HB
		F 1.4	Temperguß / Malleable cast iron, decarbonized annealed	≤ 705
		F 1.5	Temperguß / Malleable cast iron, non-decarbonized annealed	≤ 705
	Gußeisen / Cast Iron			
	F 2	F 2.1	Gußeisen mit Kugelgraphit / Nodular graphite iron	≤ 400
		F 2.2	Gußeisen mit Kugelgraphit / Nodular graphite iron	≤ 1125
		F 2.3	Gußeisen mit Vermikulargraphit / Cast iron with vermicular	< 333 HB
F 2.4		Gußeisen mit Vermikulargraphit / Cast iron with vermicular	< 333 HB	
Graphit Graphite	Graphit / Graphite			
	G 1	G 1.1	Graphit / Graphite	≤ 255
	Wolfram/Kupferlegierungen / Tungsten-copper alloys			
G 2	G 2.1	Wolfram-Kupfer Legierungen / Tungsten-copper alloys	≤ 255 HV 10	

Eine detaillierte Aufstellung über gebräuchliche Kunststoffe finden Sie in der Werkzeug Gruppe 2-4 - Fräswerkzeuge für Kunststoff / Detailed description of plastic materials to be worked is available under section 2-4 - End Mills for composite materials.

■ gut geeignet / Suggested ▲ mit Beschichtung gut geeignet / Suggested with coating

Werkstückwerkstoffe / Materials
Einsatzgebiete VHM Fräser - Werkstückwerkstoffe / Workpiece materials

Werkstoff Bezeichnung Material designation	Werkstoff Nummer Material Number	Festigkeit N/mm ² Strength N/mm ²	Frässtifte / Rotary burs						
			1 - Aluminium 1 - Aluminium	2 - Grob 2 - Course	3 - Mittel / Standard 3 - Medium	4 - Diamant 4 - Diamond	5 - Fein 5 - Fine	6 - Kreuzverzahnt 6 - Double cut	
G-AlMg3	3.3541	130 - 190							
Al 99.5 / F13	3.0255	100 - 250							
GDAlSi17Cu4		180 - 250		■					
GD-AlSi12	3.2582	220 - 300		■					
GD-AlSi9Cu3	3.2163	240 - 320		■					
AlCuMg1 / F39	3.1325	300 - 500	■	■					
MMC		600 - 1400	▲	■					
E-Cu	2.0060	220 - 350	■	■					
GCuSn5ZnPb / Rg5	2.1096	150 - 350	■	■					
GCuSn7ZnPb / Rg7	2.1090	150 - 350	■	■					
CuZn40 / Ms60	2.0360	340 - 500	■	■					
CuZn39Pb2 / Ms58	2.0380	350 - 500	■	■					
CuZn37 / Ms63	2.0321	300 - 550	■	■					
CuAl10Ni	2.0966	500 - 800	■	■					
Ampco 16		630	▲	▲	■				■
Ampco 20		600	▲	▲	■				■
MgAl6	3.5662	300 - 500	▲	▲	■				■
GMgAl9Zn1	3.5912	300 - 500	▲	▲	■				■
AFK-CFK-GFK			■				■		■
			■				■		■
			▲				■		■
			■	■			■		■
			▲	■			■		■
			■	■			■		■
Q-St-37-3	1.0123	< 400		■	■	■	■	■	■
R-Fe80	1.1014	< 400		■	■	■	■	■	■
9SMnPb28	1.0718	500 - 700		■	■	■	■	■	■
St37-2	1.0037	320 - 470		■	■	■	■	■	■
16MnCr5	1.7131	500 - 700		■	■	■	■	■	■
Ck45	1.1191	600 - 800		■	■	■	■	■	■
Gs25CrMo4	1.7218	650 - 950		■	■	■	■	■	■
St70-2	1.0070	700 - 900		■	■	■	■	■	■
100Cr6	1.3505	700 - 900			■	■	■	■	■
X155CrVMo12-1	1.2379	900 - 1100			■	■	■	■	■
X30WCrV5-3	1.2567	1100			■	■	■	■	■
42CrMo4V	1.7225	1200 - 1400			■	■	■	■	■
X38CrMoV5-3	1.2367	900 - 1100			■	■	■	■	■
55NiCrMoV6	1.2713	47 - 52 HRC			■	■	■	■	■
45WCrV7	1.2542	56 - 60 HRC			■	■	■	■	■
X155CrVMo12-1	1.2379	60 - 63 HRC			■	■	■	■	■
X210CrW12	1.2436	63 - 66 HRC			■	■	■	■	■
FeroTiC		800 - 900			■	■	■	■	■
Hardox500		1300 - 1400			■	■	■	■	■
X10NiCrAlTi32-20 (INCO.800)	1.4876	610 - 850		▲	▲	■	■	■	■
X12CrNiTi18-9	1.4878	500 - 700		▲	▲	■	■	■	■
X6CrNiMoTi17-12-2	1.4571	500 - 730		▲	▲	■	■	■	■
X45SiCr4	1.4704	900 - 1100		▲	▲	■	■	■	■
X5NiCrTi26-15	1.4980	1200		▲	▲	■	■	■	■
Ti3 (Ti99.4)	3.7055	700		▲					
TiAl6V4	3.7164	700 - 900		▲					
TiAlMo4Sn2	3.7185	900 - 1250		▲					
NiCu30Fe (MONEL400)	2.4360	420 - 610		▲	▲	■	■	■	■
NiCr19NbMo (INCONEL718)	2.4668	850-1200		▲	▲	■	■	■	■
Haynes 25 (L605)		1550 - 2000		▲	▲	■	■	■	■
GG 20	0.6020	120-220 HB			■	■	■	■	■
GG 30	0.6030	220 - 270 HB			■	■	■	■	■
		< 400 HB			■	■	■	■	■
GTW40	0.8040	360 - 420			■	■	■	■	■
GTS65	0.8165	560 - 650			■	■	■	■	■
GGG 40	0.7040	400		■	■	■	■	■	■
GGG 70	0.7070	700 - 1050		■	■	■	■	■	■
GGV (80% Perlit)		220 HB		■	■	■	■	■	■
GGV (100% Perlit)		230 HB		■	■	■	■	■	■
C-800		60		▲	▲	■	■	■	■
W-Cu 80/20		230-250 HV	▲	▲	▲				■

Eine detaillierte Aufstellung über gebräuchliche Kunststoffe finden Sie in der Werkzeug Gruppe 2-4 - Fräswerkzeuge für Kunststoff / Detailed description of plastic materials to be worked is available under section 2-4 - End Mills for composite materials.

■ gut geeignet / Suggested ▲ mit Beschichtung gut geeignet / Suggested with coating

Werkstückwerkstoffe / Materials

Einsatzgebiete VHM Fräser - Werkstückwerkstoffe / Workpiece materials

Gruppe Group	Festigkeit N/mm ² Strength N/mm ²	Werkstoff Bezeichnung Material designation	Werkstoff Nummer Material Number	Festigkeit N/mm ² Strength N/mm ²	Fräswerkzeuge / End mill tool						
					Seite / Page 111	Seite / Page 112	Seite / Page 113	Seite / Page 114	Seite / Page 115	Seite / Page 116	Seite / Page 117
					GF GM	72GT 72GTD	72GR 72GRD	73GRI 73GRID	73GTI 73GTID	108GFD 108GMD	109GFD 109GMD
A											
A 1.1	≤ 255	G-AlMg3	3.3541	130 - 190							
A 1.2	≤ 255	Al 99.5 / F13	3.0255	100 - 250							
A 1.3	≤ 255	GDAIS17Cu4		180 - 250							
A 1.4	≤ 400	GD-AlSi12	3.2582	220 - 300							
A 1.5	≤ 400	GD-AlSi9Cu3	3.2163	240 - 320							
A 1.6	≤ 705	AlCuMg1 / F39	3.1325	300 - 500							
A 1.7	≤ 705	MMC		600 - 1400							
A 2											
A 2.1	≤ 400	E-Cu	2.0060	220 - 350							
A 2.2	≤ 400	GCuSn5ZnPb / Rg5	2.1096	150 - 350							
A 2.3	≤ 400	GCuSn7ZnPb / Rg7	2.1090	150 - 350							
A 2.4	≤ 705	CuZn40 / Ms60	2.0360	340 - 500							
A 2.5	≤ 705	CuZn39Pb2 / Ms58	2.0380	350 - 500							
A 2.6	≤ 705	CuZn37 / Ms63	2.0321	300 - 550							
A 2.7	≤ 850	CuAl10Ni	2.0966	500 - 800							
A 3											
A 3.1	≤ 705	Ampco 16		630							
A 3.2	≤ 705	Ampco 20		600							
A 4											
A 4.1	≤ 705	MgAl6	3.5662	300 - 500							
A 4.2	≤ 705	GMgAl9Zn1	3.5912	300 - 500							
B											
B 1.1	110										
B 1.2	80										
B 1.3	110										
B 1.4	800-1500	AFK-CFK-GFK									
B 1.5	130										
B 1.6	110										
B 2											
B 2.1	< 80										
B 2.2	< 80										
B 2.3	< 80										
B 2.4	< 80										
C											
C 1.1	≤ 400	Q-St-37-3	1.0123	< 400							
C 1.2	≤ 400	R-Fe80	1.1014	< 400							
C 1.3	≤ 705	9SMnPb28	1.0718	500 - 700							
C 1.4	≤ 705	Si37-2	1.0037	320 - 470							
C 1.5	≤ 705	16MnCr5	1.7131	500 - 700							
C 1.6	≤ 850	Ck45	1.1191	600 - 800							
C 1.7	≤ 1125	Gs25CrMo4	1.7218	650 - 950							
C 1.8	≤ 1125	Si70-2	1.0070	700 - 900							
C 2											
C 2.1	≤ 1125	100Cr6	1.3505	700 - 900							
C 2.2	≤ 1125	X155CrVMo12-1	1.2379	900 - 1100							
C 2.3	≤ 1125	X30WCrV5-3	1.2567	1100							
C 2.4	≤ 1420	42CrMo4V	1.7225	1200 - 1400							
C 3											
C 3.1	< 44,5HRc	X38CrMoV5-3	1.2367	900 - 1100							
C 3.2	44 - 56 HRc	55NiCrMoV6	1.2713	47 - 52 HRC							
C 3.3	56 - 60 HRc	45WCrV7	1.2542	56 - 60 HRC							
C 3.4	58 - 63 HRc	X155CrVMo12-1	1.2379	60 - 63 HRC							
C 3.5	56 - 67 HRc	X210CrW12	1.2436	63 - 66 HRC							
C 4											
C 4.1	≤ 1125	FeroTiC		800 - 900							
C 4.2	≤ 1420	Hardox500		1300 - 1400							
D											
D 1.1	≤ 850	X10NiCrAlTi32-20 (INCO.800)	1.4876	610 - 850							
D 1.2	≤ 850	X12CrNiTi18-9	1.4878	500 - 700							
D 1.3	≤ 850	X6CrNiMoTi17-12-2	1.4571	500 - 730							
D 1.4	≤ 1125	X45SiCr4	1.4704	900 - 1100							
D 1.5	≤ 1420	X5NiCrTi26-15	1.4980	1200							
E											
E 1.1	≤ 705	Ti3 (Ti99,4)	3.7055	700							
E 1.2	≤ 1125	TiAl6V4	3.7164	700 - 900							
E 1.3	≤ 1420	TiAlMo4Sn2	3.7185	900 - 1250							
E 2											
E 2.1	≤ 705	NiCu30Fe (MONEL400)	2.4360	420 - 610							
E 2.2	≤ 1420	NiCr19NbMo (INCONEL718)	2.4668	850-1200							
E 2.3	≤ 2030	Haynes 25 (L605)		1550 - 2000							
F											
F 1.1	< 333 HB	GG 20	0.6020	120-220 HB							
F 1.2	< 333 HB	GG 30	0.6030	220 - 270 HB							
F 1.3	≤ 416 HB			< 400 HB							
F 1.4	≤ 705	GTW40	0.8040	360 - 420							
F 1.5	≤ 705	GTS65	0.8165	560 - 650							
F 2											
F 2.1	≤ 400	GGG 40	0.7040	400							
F 2.2	≤ 1125	GGG 70	0.7070	700 - 1050							
F 2.3	< 333 HB	GGV (80% Perlit)		220 HB							
F 2.4	< 333 HB	GGV (100% Perlit)		230 HB							
G											
G 1.1	≤ 255	C-800		60	▲	▲	▲	▲	▲	▲	▲
G 2											
G 2.1	≤ 255 HV 10	W-Cu 80/20		230-250 HV							

Eine detaillierte Aufstellung über gebräuchliche Kunststoffe finden Sie in der Werkzeug Gruppe 2-4 - Fräswerkzeuge für Kunststoff / Detailed description of plastic materials to be worked is available under section 2-4 - End Mills for composite materials.

■ gut geeignet / Suggested ▲ mit Beschichtung gut geeignet / Suggested with coating

Werkstückwerkstoffe / Materials
Einsatzgebiete VHM Fräser - Werkstückwerkstoffe / Workpiece materials

Gruppe Group	Festigkeit N/mm ² Strength N/mm ²	Werkstoff Bezeichnung Material designation	Werkstoff Nummer Material Number	Festigkeit N/mm ² Strength N/mm ²	Fräserwerkzeuge / End mill tool						
					Seite / Page 137	Seite / Page 138	Seite / Page 139	Seite / Page 148	Seite / Page 149	Seite / Page 150	Seite / Page 151
A					106RF 106RM	102S 102SE	77SU 77SUE	110TD 110TDG	110TDR 110TDRG	110A 110AG	111A 111AG
A 1.1	≤ 255	G-AlMg3	3.3541	130 - 190		■	■	■	■	■	■
A 1.2	≤ 255	Al 99.5 / F13	3.0255	100 - 250		■		■	■	■	■
A 1.3	≤ 255	GDAISI17Cu4		180 - 250				▲	▲	▲	▲
A 1.4	≤ 400	GD-AlSi12	3.2582	220 - 300				▲	▲	▲	▲
A 1.5	≤ 400	GD-AlSi9Cu3	3.2163	240 - 320				▲	▲	▲	▲
A 1.6	≤ 705	AlCuMg1 / F39	3.1325	300 - 500				■	■	■	■
A 1.7	≤ 705	MMC		600 - 1400					▲	▲	▲
A 2											
A 2.1	≤ 400	E-Cu	2.0060	220 - 350				■	■	■	■
A 2.2	≤ 400	GCuSn5ZnPb / Rg5	2.1096	150 - 350				■	■	■	■
A 2.3	≤ 400	GCuSn7ZnPb / Rg7	2.1090	150 - 350				■	■	■	■
A 2.4	≤ 705	CuZn40 / Ms60	2.0360	340 - 500				▲	▲	▲	▲
A 2.5	≤ 705	CuZn39Pb2 / Ms58	2.0380	350 - 500				▲	▲	▲	▲
A 2.6	≤ 705	CuZn37 / Ms63	2.0321	300 - 550				▲	▲	▲	▲
A 2.7	≤ 850	CuAl10Ni	2.0966	500 - 800				▲	▲	▲	▲
A 3											
A 3.1	≤ 705	Ampco 16		630				▲	▲	▲	▲
A 3.2	≤ 705	Ampco 20		600				▲	▲	▲	▲
A 4											
A 4.1	≤ 705	MgAl6	3.5662	300 - 500				▲	▲	▲	▲
A 4.2	≤ 705	GMgAl9Zn1	3.5912	300 - 500				▲	▲	▲	▲
B											
B 1.1	110					■		■	■		
B 1.2	80					■		■	■		
B 1.3	110					■		■	■		
B 1.4	800-1500	AFK-CFK-GFK			▲		■				
B 1.5	130					■		■	■		
B 1.6	110					■		■	■		
B 2											
B 2.1	< 80							■	■		
B 2.2	< 80							■	■		
B 2.3	< 80					■		■	■		
B 2.4	< 80					■		■	■		
C											
C 1.1	≤ 400	Q-St-37-3	1.0123	< 400							
C 1.2	≤ 400	R-Fe80	1.1014	< 400							
C 1.3	≤ 705	9SMnPb28	1.0718	500 - 700							
C 1.4	≤ 705	St37-2	1.0037	320 - 470							
C 1.5	≤ 705	16MnCr5	1.7131	500 - 700							
C 1.6	≤ 850	Ck45	1.1191	600 - 800							
C 1.7	≤ 1125	Gs25CrMo4	1.7218	650 - 950							
C 1.8	≤ 1125	St70-2	1.0070	700 - 900							
C 2											
C 2.1	≤ 1125	100Cr6	1.3505	700 - 900							
C 2.2	≤ 1125	X155CrVMo12-1	1.2379	900 - 1100							
C 2.3	≤ 1125	X30WCrV5-3	1.2567	1100							
C 2.4	≤ 1420	42CrMo4V	1.7225	1200 - 1400							
C 3											
C 3.1	< 44,5HRc	X38CrMoV5-3	1.2367	900 - 1100							
C 3.2	44 - 56 HRc	55NiCrMoV6	1.2713	47 - 52 HRC							
C 3.3	56 - 60 HRc	45WCrV7	1.2542	56 - 60 HRC							
C 3.4	58 - 63 HRc	X155CrVMo12-1	1.2379	60 - 63 HRC							
C 3.5	56 - 67 HRc	X210CrW12	1.2436	63 - 66 HRC							
C 4											
C 4.1	≤ 1125	FeroTiC		800 - 900							
C 4.2	≤ 1420	Hardox500		1300 - 1400							
D											
D 1.1	≤ 850	X10NiCrAlTi32-20 (INCO.800)	1.4876	610 - 850							
D 1.2	≤ 850	X12CrNiTi18-9	1.4878	500 - 700							
D 1.3	≤ 850	X6CrNiMoTi17-12-2	1.4571	500 - 730							
D 1.4	≤ 1125	X45SiCr4	1.4704	900 - 1100							
D 1.5	≤ 1420	X5NiCrTi26-15	1.4980	1200							
E											
E 1.1	≤ 705	Ti3 (Ti99.4)	3.7055	700							
E 1.2	≤ 1125	TiAl6V4	3.7164	700 - 900							
E 1.3	≤ 1420	TiAlMo4Sn2	3.7185	900 - 1250							
E 2											
E 2.1	≤ 705	NiCu30Fe (MONEL400)	2.4360	420 - 610							
E 2.2	≤ 1420	NiCr19NbMo (INCONEL718)	2.4668	850-1200							
E 2.3	≤ 2030	Haynes 25 (L605)		1550 - 2000							
F											
F 1.1	< 333 HB	GG 20	0.6020	120-220 HB							
F 1.2	< 333 HB	GG 30	0.6030	220 - 270 HB							
F 1.3	≤ 416 HB			< 400 HB							
F 1.4	≤ 705	GTW40	0.8040	360 - 420							
F 1.5	≤ 705	GTS65	0.8165	560 - 650							
F 2											
F 2.1	≤ 400	GGG 40	0.7040	400							
F 2.2	≤ 1125	GGG 70	0.7070	700 - 1050							
F 2.3	< 333 HB	GGV (80% Perlit)		220 HB							
F 2.4	< 333 HB	GGV (100% Perlit)		230 HB							
G											
G 1.1	≤ 255	C-800		60							
G 2											
G 2.1	≤ 255 HV 10	W-Cu 80/20		230-250 HV							

Eine detaillierte Aufstellung über gebräuchliche Kunststoffe finden Sie in der Werkzeug Gruppe 2-4 - Fräserwerkzeuge für Kunststoff / Detailed description of plastic materials to be worked is available under section 2-4 - End Mills for composite materials.

■ gut geeignet / Suggested ▲ mit Beschichtung gut geeignet / Suggested with coating

Werkstückwerkstoffe / Materials
Einsatzgebiete VHM Fräser - Werkstückwerkstoffe / Workpiece materials

Gruppe Group	Festigkeit N/mm ² Strength N/mm ²	Werkstoff Bezeichnung Material designation	Werkstoff Nummer Material Number	Festigkeit N/mm ² Strength N/mm ²	Fräserwerkzeuge / End mill tool						
					Seite / Page 166	Seite / Page 167	Seite / Page 168	Seite / Page 169	Seite / Page 175	Seite / Page 176	Seite / Page 177
A					103TI	103I-45°	103RI	110SP	64SS / 64SSC	63SP / 63SPC	63SP-45° / 63SP-45°C
					103TIG	103I-45°G	103RIG	110SPG	64SSW / 64SSWC	63SPW / 63SPWC	63SPW-45° / 63SPW-45°C
A 1.1	≤ 255	G-AlMg3	3.3541	130 - 190	■	■	■				
A 1.2	≤ 255	Al 99.5 / F13	3.0255	100 - 250	■	■	■				
A 1.3	≤ 255	GDAISI17Cu4		180 - 250	▲	▲	▲				
A 1.4	≤ 400	GD-AISI12	3.2582	220 - 300	▲	▲	▲				
A 1.5	≤ 400	GD-AISI9Cu3	3.2163	240 - 320	▲	▲	▲				
A 1.6	≤ 705	AlCuMg1 / F39	3.1325	300 - 500	■	■	■				▲
A 1.7	≤ 705	MMC		600 - 1400	▲	▲	▲				▲
A 2											
A 2.1	≤ 400	E-Cu	2.0060	220 - 350	■	■	■				
A 2.2	≤ 400	GCuSn5ZnPb / Rg5	2.1096	150 - 350	■	■	■				
A 2.3	≤ 400	GCuSn7ZnPb / Rg7	2.1090	150 - 350	■	■	■				
A 2.4	≤ 705	CuZn40 / Ms60	2.0360	340 - 500	▲	▲	▲				▲
A 2.5	≤ 705	CuZn39Pb2 / Ms58	2.0380	350 - 500	▲	▲	▲				▲
A 2.6	≤ 705	CuZn37 / Ms63	2.0321	300 - 550	▲	▲	▲				▲
A 2.7	≤ 850	CuAl10Ni	2.0966	500 - 800	▲	▲	▲				▲
A 3											
A 3.1	≤ 705	Ampco 16		630	▲	▲	▲				
A 3.2	≤ 705	Ampco 20		600	▲	▲	▲				
A 4											
A 4.1	≤ 705	MgAl6	3.5662	300 - 500	▲	▲	▲				
A 4.2	≤ 705	GMgAl9Zn1	3.5912	300 - 500	▲	▲	▲				
B											
B 1.1	110							■			
B 1.2	80							■			
B 1.3	110							■			
B 1.4	800-1500	AFK-CFK-GFK						■			
B 1.5	130							■			
B 1.6	110							■			
B 2											
B 2.1	< 80										
B 2.2	< 80										
B 2.3	< 80										
B 2.4	< 80										
C											
C 1.1	≤ 400	Q-St-37-3	1.0123	< 400					▲	▲	
C 1.2	≤ 400	R-Fe80	1.1014	< 400					▲	▲	
C 1.3	≤ 705	9SMnPb28	1.0718	500 - 700					▲	▲	
C 1.4	≤ 705	Si37-2	1.0037	320 - 470					▲	▲	
C 1.5	≤ 705	16MnCr5	1.7131	500 - 700					▲	▲	
C 1.6	≤ 850	Ck45	1.1191	600 - 800					▲	▲	▲
C 1.7	≤ 1125	Gs25CrMo4	1.7218	650 - 950					▲	▲	▲
C 1.8	≤ 1125	St70-2	1.0070	700 - 900					▲	▲	▲
C 2											
C 2.1	≤ 1125	100Cr6	1.3505	700 - 900					▲	▲	▲
C 2.2	≤ 1125	X155CrVMo12-1	1.2379	900 - 1100					▲	▲	▲
C 2.3	≤ 1125	X30WCrV5-3	1.2567	1100					▲	▲	▲
C 2.4	≤ 1420	42CrMo4V	1.7225	1200 - 1400					▲	▲	▲
C 3											
C 3.1	< 44,5HRc	X38CrMoV5-3	1.2367	900 - 1100					▲	▲	▲
C 3.2	44 - 56 HRc	55NiCrMoV6	1.2713	47 - 52 HRC					▲	▲	▲
C 3.3	56 - 60 HRc	45WCrV7	1.2542	56 - 60 HRC					▲	▲	▲
C 3.4	58 - 63 HRc	X155CrVMo12-1	1.2379	60 - 63 HRC					▲	▲	▲
C 3.5	56 - 67 HRc	X210CrW12	1.2436	63 - 66 HRC					▲	▲	▲
C 4											
C 4.1	≤ 1125	FeroTiC		800 - 900					▲	▲	▲
C 4.2	≤ 1420	Hardox500		1300 - 1400					▲	▲	▲
D											
D 1.1	≤ 850	X10NiCrAlTi32-20 (INCO.800)	1.4876	610 - 850					▲	▲	▲
D 1.2	≤ 850	X12CrNiTi18-9	1.4878	500 - 700					▲	▲	▲
D 1.3	≤ 850	X6CrNiMoTi17-12-2	1.4571	500 - 730					▲	▲	▲
D 1.4	≤ 1125	X45SiCr4	1.4704	900 - 1100					▲	▲	▲
D 1.5	≤ 1420	X5NiCrTi26-15	1.4980	1200					▲	▲	▲
E											
E 1.1	≤ 705	Ti3 (Ti99.4)	3.7055	700					▲	▲	▲
E 1.2	≤ 1125	TiAl6V4	3.7164	700 - 900					▲	▲	▲
E 1.3	≤ 1420	TiAlMo4Sn2	3.7185	900 - 1250					▲	▲	▲
E 2											
E 2.1	≤ 705	NiCu30Fe (MONEL400)	2.4360	420 - 610					▲	▲	▲
E 2.2	≤ 1420	NiCr19NbMo (INCONEL718)	2.4668	850-1200					▲	▲	▲
E 2.3	≤ 2030	Haynes 25 (L605)		1550 - 2000					▲	▲	▲
F											
F 1.1	< 333 HB	GG 20	0.6020	120-220 HB					▲	▲	▲
F 1.2	< 333 HB	GG 30	0.6030	220 - 270 HB					▲	▲	▲
F 1.3	≤ 416 HB			< 400 HB					▲	▲	▲
F 1.4	≤ 705	GTW40	0.8040	360 - 420					▲	▲	▲
F 1.5	≤ 705	GTS65	0.8165	560 - 650					▲	▲	▲
F 2											
F 2.1	≤ 400	GGG 40	0.7040	400					▲	▲	▲
F 2.2	≤ 1125	GGG 70	0.7070	700 - 1050					▲	▲	▲
F 2.3	< 333 HB	GGV (80% Perlit)		220 HB					▲	▲	▲
F 2.4	< 333 HB	GGV (100% Perlit)		230 HB					▲	▲	▲
G											
G 1.1	≤ 255	C-800		60							
G 2											
G 2.1	≤ 255 HV 10	W-Cu 80/20		230-250 HV							

Eine detaillierte Aufstellung über gebräuchliche Kunststoffe finden Sie in der Werkzeug Gruppe 2-4 - Fräserwerkzeuge für Kunststoff / Detailed description of plastic materials to be worked is available under section 2-4 - End Mills for composite materials.

■ gut geeignet / Suggested ▲ mit Beschichtung gut geeignet / Suggested with coating

Werkstückwerkstoffe / Materials
Einsatzgebiete VHM Fräser - Werkstückwerkstoffe / Workpiece materials

Gruppe Group	Festigkeit N/mm ² Strength N/mm ²	Werkstoff Bezeichnung Material designation	Werkstoff Nummer Material Number	Festigkeit N/mm ² Strength N/mm ²	Fräswerkzeuge / End mill tool							
					Seite / Page 195	Seite / Page 196	Seite / Page 197	Seite / Page 198	Seite / Page 199	Seite / Page 200	Seite / Page 201	
A					63TISQC 63TISQC	63 / 63A 63W / 63WA	63-45° / 63-45°A 63W-45° / 63W-45°A	63L 63LA	63XL 63XLA	63R / 63RA 63RW / 63RWA	63RL 63RLA	
A 1.1	≤ 255	G-AlMg3	3.3541	130 - 190								
A 1.2	≤ 255	Al 99.5 / F13	3.0255	100 - 250								
A 1.3	≤ 255	GDAISI17Cu4		180 - 250	■		■					
A 1.4	≤ 400	GD-AISI12	3.2582	220 - 300	■		■					
A 1.5	≤ 400	GD-AISI9Cu3	3.2163	240 - 320	■		■					
A 1.6	≤ 705	AlCuMg1 / F39	3.1325	300 - 500	■		■					
A 1.7	≤ 705	MMC		600 - 1400	■		■					
A 2												
A 2.1	≤ 400	E-Cu	2.0060	220 - 350								
A 2.2	≤ 400	GCuSn5ZnPb / Rg5	2.1096	150 - 350								
A 2.3	≤ 400	GCuSn7ZnPb / Rg7	2.1090	150 - 350								
A 2.4	≤ 705	CuZn40 / Ms60	2.0360	340 - 500	■		■					
A 2.5	≤ 705	CuZn39Pb2 / Ms58	2.0380	350 - 500	■		■					
A 2.6	≤ 705	CuZn37 / Ms63	2.0321	300 - 550	■		■					
A 2.7	≤ 850	CuAl10Ni	2.0966	500 - 800	■		■					
A 3												
A 3.1	≤ 705	Ampco 16		630	■		■					
A 3.2	≤ 705	Ampco 20		600	■		■					
A 4												
A 4.1	≤ 705	MgAl6	3.5662	300 - 500	■		■					
A 4.2	≤ 705	GMgAl9Zn1	3.5912	300 - 500	■		■					
B												
B 1.1	110											
B 1.2	80											
B 1.3	110											
B 1.4	800-1500	AFK-CFK-GFK										
B 1.5	130											
B 1.6	110											
B 2												
B 2.1	< 80											
B 2.2	< 80											
B 2.3	< 80											
B 2.4	< 80											
C												
C 1.1	≤ 400	Q-St-37-3	1.0123	< 400	■	■	■	■	■	■	■	■
C 1.2	≤ 400	R-Fe80	1.1014	< 400	■	■	■	■	■	■	■	■
C 1.3	≤ 705	9SMnPb28	1.0718	500 - 700	■	■	■	■	■	■	■	■
C 1.4	≤ 705	Si37-2	1.0037	320 - 470	■	■	■	■	■	■	■	■
C 1.5	≤ 705	16MnCr5	1.7131	500 - 700	▲	▲	▲	▲	▲	▲	▲	▲
C 1.6	≤ 850	Ck45	1.1191	600 - 800	▲	▲	▲	▲	▲	▲	▲	▲
C 1.7	≤ 1125	Gs25CrMo4	1.7218	650 - 950	▲	▲	▲	▲	▲	▲	▲	▲
C 1.8	≤ 1125	Si70-2	1.0070	700 - 900	▲	▲	▲	▲	▲	▲	▲	▲
C 2												
C 2.1	≤ 1125	100Cr6	1.3505	700 - 900	▲	▲	▲	▲	▲	▲	▲	▲
C 2.2	≤ 1125	X155CrVMo12-1	1.2379	900 - 1100	▲	▲	▲	▲	▲	▲	▲	▲
C 2.3	≤ 1125	X30WCrV5-3	1.2567	1100	▲	▲	▲	▲	▲	▲	▲	▲
C 2.4	≤ 1420	42CrMo4V	1.7225	1200 - 1400	▲	▲	▲	▲	▲	▲	▲	▲
C 3												
C 3.1	< 44,5HRc	X38CrMoV5-3	1.2367	900 - 1100	▲	▲	▲	▲	▲	▲	▲	▲
C 3.2	44 - 56 HRC	55NiCrMoV6	1.2713	47 - 52 HRC	▲	▲	▲	▲	▲	▲	▲	▲
C 3.3	56 - 60 HRC	45WCrV7	1.2542	56 - 60 HRC								
C 3.4	58 - 63 HRC	X155CrVMo12-1	1.2379	60 - 63 HRC								
C 3.5	56 - 67 HRC	X210CrW12	1.2436	63 - 66 HRC								
C 4												
C 4.1	≤ 1125	FeroTiC		800 - 900	▲		▲	▲	▲	▲	▲	▲
C 4.2	≤ 1420	Hardox500		1300 - 1400	▲		▲	▲	▲	▲	▲	▲
D												
D 1.1	≤ 850	X10NiCrAlTi32-20 (INCO.800)	1.4876	610 - 850	▲		▲	▲	▲	▲	▲	▲
D 1.2	≤ 850	X12CrNiTi18-9	1.4878	500 - 700	▲		▲	▲	▲	▲	▲	▲
D 1.3	≤ 850	X6CrNiMoTi17-12-2	1.4571	500 - 730	▲		▲	▲	▲	▲	▲	▲
D 1.4	≤ 1125	X45SiCr4	1.4704	900 - 1100	▲		▲	▲	▲	▲	▲	▲
D 1.5	≤ 1420	X5NiCrTi26-15	1.4980	1200	▲		▲	▲	▲	▲	▲	▲
E												
E 1.1	≤ 705	Ti3 (Ti99.4)	3.7055	700	▲		▲					
E 1.2	≤ 1125	TiAl6V4	3.7164	700 - 900	▲		▲					
E 1.3	≤ 1420	TiAlMo4Sn2	3.7185	900 - 1250	▲		▲					
E 2												
E 2.1	≤ 705	NiCu30Fe (MONEL400)	2.4360	420 - 610	▲		▲					
E 2.2	≤ 1420	NiCr19NbMo (INCONEL718)	2.4668	850-1200	▲		▲					
E 2.3	≤ 2030	Haynes 25 (L605)		1550 - 2000								
F												
F 1.1	< 333 HB	GG 20	0.6020	120-220 HB	▲	▲	▲	▲	▲	▲	▲	▲
F 1.2	< 333 HB	GG 30	0.6030	220 - 270 HB	▲	▲	▲	▲	▲	▲	▲	▲
F 1.3	≤ 416 HB			< 400 HB		▲	▲	▲	▲	▲	▲	▲
F 1.4	≤ 705	GTW40	0.8040	360 - 420	▲	▲	▲	▲	▲	▲	▲	▲
F 1.5	≤ 705	GTS65	0.8165	560 - 650	▲	▲	▲	▲	▲	▲	▲	▲
F 2												
F 2.1	≤ 400	GGG 40	0.7040	400	▲	▲	▲	▲	▲	▲	▲	▲
F 2.2	≤ 1125	GGG 70	0.7070	700 - 1050	▲	▲	▲	▲	▲	▲	▲	▲
F 2.3	< 333 HB	GGV (80% Perlit)		220 HB	▲	▲	▲	▲	▲	▲	▲	▲
F 2.4	< 333 HB	GGV (100% Perlit)		230 HB	▲	▲	▲	▲	▲	▲	▲	▲
G												
G 1.1	≤ 255	C-800		60								
G 2												
G 2.1	≤ 255 HV 10	W-Cu 80/20		230-250 HV								

Eine detaillierte Aufstellung über gebräuchliche Kunststoffe finden Sie in der Werkzeug Gruppe 2-4 - Fräswerkzeuge für Kunststoff / Detailed description of plastic materials to be worked is available under section 2-4 - End Mills for composite materials.

■ gut geeignet / Suggested ▲ mit Beschichtung gut geeignet / Suggested with coating

Werkstückwerkstoffe / Materials

Einsatzgebiete VHM Fräser - Werkstückwerkstoffe / Workpiece materials

Gruppe Group	Festigkeit N/mm ² Strength N/mm ²	Werkstoff Bezeichnung Material designation	Werkstoff Nummer Material Number	Festigkeit N/mm ² Strength N/mm ²	Fräswerkzeuge / End mill tool				Bohrwerkzeuge / Drills			
					Seite / Page 218	Seite / Page 219	Seite / Page 238	Seite / Page 239	Seite / Page 240	Seite / Page 241	Seite / Page 242	
A					66M 66MA	66MR 66MRA	171 171F	170-90° / 170-90°F 170-120° / 170-120°F	181 181F	182 182F	117 117D	
A 1.1	≤ 255	G-AlMg3	3.3541	130 - 190								
A 1.2	≤ 255	Al 99.5 / F13	3.0255	100 - 250								
A 1.3	≤ 255	GDAISI17Cu4		180 - 250								
A 1.4	≤ 400	GD-AISI12	3.2582	220 - 300								
A 1.5	≤ 400	GD-AISI9Cu3	3.2163	240 - 320								
A 1.6	≤ 705	AlCuMg1 / F39	3.1325	300 - 500								
A 1.7	≤ 705	MMC		600 - 1400								
A 2												
A 2.1	≤ 400	E-Cu	2.0060	220 - 350								
A 2.2	≤ 400	GCuSn5ZnPb / Rg5	2.1096	150 - 350								
A 2.3	≤ 400	GCuSn7ZnPb / Rg7	2.1090	150 - 350								
A 2.4	≤ 705	CuZn40 / Ms60	2.0360	340 - 500								
A 2.5	≤ 705	CuZn39Pb2 / Ms58	2.0380	350 - 500								
A 2.6	≤ 705	CuZn37 / Ms63	2.0321	300 - 550								
A 2.7	≤ 850	CuAl10Ni	2.0966	500 - 800								
A 3												
A 3.1	≤ 705	Ampco 16		630								
A 3.2	≤ 705	Ampco 20		600								
A 4												
A 4.1	≤ 705	MgAl6	3.5662	300 - 500								
A 4.2	≤ 705	GMgAl9Zn1	3.5912	300 - 500								
B												
B 1.1	110											
B 1.2	80											
B 1.3	110											
B 1.4	800-1500	AFK-CFK-GFK										▲
B 1.5	130											
B 1.6	110											
B 2												
B 2.1	< 80											
B 2.2	< 80											
B 2.3	< 80											
B 2.4	< 80											
C												
C 1.1	≤ 400	Q-St-37-3	1.0123	< 400								
C 1.2	≤ 400	R-Fe80	1.1014	< 400								
C 1.3	≤ 705	9SMnPb28	1.0718	500 - 700	■							
C 1.4	≤ 705	Si37-2	1.0037	320 - 470	■							
C 1.5	≤ 705	16MnCr5	1.7131	500 - 700	▲	▲						
C 1.6	≤ 850	Ck45	1.1191	600 - 800	▲	▲						
C 1.7	≤ 1125	Gs25CrMo4	1.7218	650 - 950	▲	▲						
C 1.8	≤ 1125	Si70-2	1.0070	700 - 900	▲	▲						
C 2												
C 2.1	≤ 1125	100Cr6	1.3505	700 - 900	▲	▲						
C 2.2	≤ 1125	X155CrVMo12-1	1.2379	900 - 1100	▲	▲						
C 2.3	≤ 1125	X30WCrV5-3	1.2567	1100	▲	▲						
C 2.4	≤ 1420	42CrMo4V	1.7225	1200 - 1400	▲	▲						
C 3												
C 3.1	< 44,5HRC	X38CrMoV5-3	1.2367	900 - 1100	▲	▲						
C 3.2	44 - 56 HRC	55NiCrMoV6	1.2713	47 - 52 HRC	▲	▲						
C 3.3	56 - 60 HRC	45WCrV7	1.2542	56 - 60 HRC	▲	▲						
C 3.4	58 - 63 HRC	X155CrVMo12-1	1.2379	60 - 63 HRC	▲	▲						
C 3.5	56 - 67 HRC	X210CrW12	1.2436	63 - 66 HRC	▲	▲						
C 4												
C 4.1	≤ 1125	FeroTiC		800 - 900	▲	▲						
C 4.2	≤ 1420	Hardox500		1300 - 1400	▲	▲						
D												
D 1.1	≤ 850	X10NiCrAlTi32-20 (INCO.800)	1.4876	610 - 850		▲						
D 1.2	≤ 850	X12CrNiTi18-9	1.4878	500 - 700		▲						
D 1.3	≤ 850	X6CrNiMoTi17-12-2	1.4571	500 - 730		▲						
D 1.4	≤ 1125	X45SiCr4	1.4704	900 - 1100		▲						
D 1.5	≤ 1420	X5NiCrTi26-15	1.4980	1200		▲						
E												
E 1.1	≤ 705	Ti3 (Ti99.4)	3.7055	700								
E 1.2	≤ 1125	TiAl6V4	3.7164	700 - 900								
E 1.3	≤ 1420	TiAlMo4Sn2	3.7185	900 - 1250								
E 2												
E 2.1	≤ 705	NiCu30Fe (MONEL400)	2.4360	420 - 610	▲							
E 2.2	≤ 1420	NiCr19NbMo (INCONEL718)	2.4668	850-1200	▲							
E 2.3	≤ 2030	Haynes 25 (L605)		1550 - 2000	▲							
F												
F 1.1	< 333 HB	GG 20	0.6020	120-220 HB	▲	▲						
F 1.2	< 333 HB	GG 30	0.6030	220 - 270 HB	▲	▲						
F 1.3	≤ 416 HB			< 400 HB	▲	▲						
F 1.4	≤ 705	GTW40	0.8040	360 - 420		▲						
F 1.5	≤ 705	GTS65	0.8165	560 - 650		▲						
F 2												
F 2.1	≤ 400	GGG 40	0.7040	400	▲	▲						
F 2.2	≤ 1125	GGG 70	0.7070	700 - 1050	▲	▲						
F 2.3	< 333 HB	GGV (80% Perlit)		220 HB	▲	▲						
F 2.4	< 333 HB	GGV (100% Perlit)		230 HB	▲	▲						
G												
G 1.1	≤ 255	C-800		60								
G 2												
G 2.1	≤ 255 HV 10	W-Cu 80/20		230-250 HV								

Eine detaillierte Aufstellung über gebräuchliche Kunststoffe finden Sie in der Werkzeug Gruppe 2-4 - Fräswerkzeuge für Kunststoff / Detailed description of plastic materials to be worked is available under section 2-4 - End Mills for composite materials.

■ gut geeignet / Suggested ▲ mit Beschichtung gut geeignet / Suggested with coating

Werkstückwerkstoffe / Materials
Einsatzgebiete VHM Fräser - Werkstückwerkstoffe / Workpiece materials

Gruppe Group	Festigkeit N/mm ² Strength N/mm ²	Werkstoff Bezeichnung Material designation	Werkstoff Nummer Material Number	Festigkeit N/mm ² Strength N/mm ²	Bohrwerkzeuge / Drills					
					Seite / Page 264					
A					176					
					176F					
A 1.1	≤ 255	G-AlMg3	3.3541	130 - 190						
A 1.2	≤ 255	Al 99.5 / F13	3.0255	100 - 250						
A 1.3	≤ 255	GDAlSi17Cu4		180 - 250						
A 1.4	≤ 400	GD-AlSi12	3.2582	220 - 300						
A 1.5	≤ 400	GD-AlSi9Cu3	3.2163	240 - 320						
A 1.6	≤ 705	AlCuMg1 / F39	3.1325	300 - 500						
A 1.7	≤ 705	MMC		600 - 1400						
A 2										
A 2.1	≤ 400	E-Cu	2.0060	220 - 350						
A 2.2	≤ 400	GCuSn5ZnPb / Rg5	2.1096	150 - 350						
A 2.3	≤ 400	GCuSn7ZnPb / Rg7	2.1090	150 - 350						
A 2.4	≤ 705	CuZn40 / Ms60	2.0360	340 - 500						
A 2.5	≤ 705	CuZn39Pb2 / Ms58	2.0380	350 - 500						
A 2.6	≤ 705	CuZn37 / Ms63	2.0321	300 - 550						
A 2.7	≤ 850	CuAl10Ni	2.0966	500 - 800						
A 3										
A 3.1	≤ 705	Ampco 16		630						
A 3.2	≤ 705	Ampco 20		600						
A 4										
A 4.1	≤ 705	MgAl6	3.5662	300 - 500						
A 4.2	≤ 705	GMgAl9Zn1	3.5912	300 - 500						
B										
B 1.1	110									
B 1.2	80									
B 1.3	110									
B 1.4	800-1500	AFK-CFK-GFK								
B 1.5	130									
B 1.6	110									
B 2										
B 2.1	< 80									
B 2.2	< 80									
B 2.3	< 80									
B 2.4	< 80									
C										
C 1.1	≤ 400	Q-St-37-3	1.0123	< 400	▲					
C 1.2	≤ 400	R-Fe80	1.1014	< 400	▲					
C 1.3	≤ 705	9SMnPb28	1.0718	500 - 700	▲					
C 1.4	≤ 705	Si37-2	1.0037	320 - 470	▲					
C 1.5	≤ 705	16MnCr5	1.7131	500 - 700	▲					
C 1.6	≤ 850	Ck45	1.1191	600 - 800	▲					
C 1.7	≤ 1125	Gs25CrMo4	1.7218	650 - 950	▲					
C 1.8	≤ 1125	Si70-2	1.0070	700 - 900	▲					
C 2										
C 2.1	≤ 1125	100Cr6	1.3505	700 - 900	▲					
C 2.2	≤ 1125	X155CrVMo12-1	1.2379	900 - 1100	▲					
C 2.3	≤ 1125	X30WCrV5-3	1.2567	1100	▲					
C 2.4	≤ 1420	42CrMo4V	1.7225	1200 - 1400	▲					
C 3										
C 3.1	< 44,5HRc	X38CrMoV5-3	1.2367	900 - 1100	▲					
C 3.2	44 - 56 HRc	55NiCrMoV6	1.2713	47 - 52 HRC	▲					
C 3.3	56 - 60 HRc	45WCrV7	1.2542	56 - 60 HRC						
C 3.4	58 - 63 HRc	X155CrVMo12-1	1.2379	60 - 63 HRC						
C 3.5	56 - 67 HRc	X210CrW12	1.2436	63 - 66 HRC						
C 4										
C 4.1	≤ 1125	FeroTiC		800 - 900	▲					
C 4.2	≤ 1420	Hardox500		1300 - 1400	▲					
D										
D 1.1	≤ 850	X10NiCrAlTi32-20 (INCO.800)	1.4876	610 - 850	▲					
D 1.2	≤ 850	X12CrNiTi18-9	1.4878	500 - 700						
D 1.3	≤ 850	X6CrNiMoTi17-12-2	1.4571	500 - 730						
D 1.4	≤ 1125	X45SiCr4	1.4704	900 - 1100						
D 1.5	≤ 1420	X5NiCrTi26-15	1.4980	1200						
E										
E 1.1	≤ 705	Ti3 (Ti99.4)	3.7055	700						
E 1.2	≤ 1125	TiAl6V4	3.7164	700 - 900						
E 1.3	≤ 1420	TiAlMo4Sn2	3.7185	900 - 1250						
E 2										
E 2.1	≤ 705	NiCu30Fe (MONEL400)	2.4360	420 - 610						
E 2.2	≤ 1420	NiCr19NbMo (INCONEL718)	2.4668	850-1200						
E 2.3	≤ 2030	Haynes 25 (L605)		1550 - 2000						
F										
F 1.1	< 333 HB	GG 20	0.6020	120-220 HB						
F 1.2	< 333 HB	GG 30	0.6030	220 - 270 HB						
F 1.3	≤ 416 HB			< 400 HB						
F 1.4	≤ 705	GTW40	0.8040	360 - 420						
F 1.5	≤ 705	GTS65	0.8165	560 - 650						
F 2										
F 2.1	≤ 400	GGG 40	0.7040	400						
F 2.2	≤ 1125	GGG 70	0.7070	700 - 1050						
F 2.3	< 333 HB	GGV (80% Perlit)		220 HB						
F 2.4	< 333 HB	GGV (100% Perlit)		230 HB						
G										
G 1.1	≤ 255	C-800		60						
G 2										
G 2.1	≤ 255 HV 10	W-Cu 80/20		230-250 HV						









Eine detaillierte Aufstellung über gebräuchliche Kunststoffe finden Sie in der Werkzeug Gruppe 2-4 - Fräswerkzeuge für Kunststoff / Detailed description of plastic materials to be worked is available under section 2-4 - End Mills for composite materials.

■ gut geeignet / Suggested ▲ mit Beschichtung gut geeignet / Suggested with coating



Frässtifte
Rotary burs





WERKZEUG - GRUPPE 1
TOOL - GROUP 1
STANDARD ROTIERFRÄSER - FRÄSSTIFTE / STANDARD ROTARY BURS

Form Shape	Schaftabmessungen Shank dimensions	Ident - Nr. Code	Seite Page	
ZYA Ohne Stirnverzahnung <i>Cylindrical without end cut</i>	Ø 2,35 mm	20	41	
	Ø 3,00 mm	40	41	
	Standard / Standard	30	41	
	Schaftlänge / Shank length 100 mm	30-100	55	
	Schaftlänge / Shank length 150 mm	30-150	57	
Schaftlänge / Shank length 300 mm	30-300	59		
ZYA/ST Mit Stirnverzahnung <i>Cylindrical with end cut</i>	Ø 2,35 mm	20-ST	42	
	Ø 3,00 mm	40-ST	42	
	Standard / Standard	30-ST	42	
	Schaftlänge / Shank length 100 mm	30-ST100	55	
	Schaftlänge / Shank length 150 mm	30-ST150	57	
Schaftlänge / Shank length 300 mm	30-ST300	59		
WRC Walzenrund <i>Cylindrical radius end</i>	Ø 2,35 mm	21	43	
	Ø 3,00 mm	41	43	
	Standard / Standard	31	43	
	Schaftlänge / Shank length 100 mm	31-100	55	
	Schaftlänge / Shank length 150 mm	31-150	57	
Schaftlänge / Shank length 300 mm	31-300	59		
KEL Rundbogen <i>Taper radius end</i>	Ø 2,35 mm	22	44	
	Ø 3,00 mm	42	44	
	Standard / Standard	32	44	
	Schaftlänge / Shank length 100 mm	32-100	55	
	Schaftlänge / Shank length 150 mm	32-150	57	
Schaftlänge / Shank length 300 mm	32-300	59		
RBF Rundbogen <i>Tree with radius end</i>	Ø 2,35 mm	23	45	
	Ø 3,00 mm	43	45	
	Standard / Standard	33	45	
	Schaftlänge / Shank length 100 mm	33-100	56	
	Schaftlänge / Shank length 150 mm	33-150	58	
Schaftlänge / Shank length 300 mm	33-300	60		
SPG Spitzbogen <i>Tree with pointed end</i>	Ø 2,35 mm	24	46	
	Ø 3,00 mm	44	46	
	Standard / Standard	34	46	
	Schaftlänge / Shank length 100 mm	34-100	56	
	Schaftlänge / Shank length 150 mm	34-150	58	
Schaftlänge / Shank length 300 mm	34-300	60		
SKM Spitzkegel <i>Conical</i>	Ø 2,35 mm	25	47	
	Ø 3,00 mm	45	47	
	Standard / Standard	35	47	
KSK-90° Kegel <i>90° Conical</i>	Ø 3,00 mm	46-90°	48	
	Standard / Standard	36-90°	48	

01

WERKZEUG - GRUPPE 1
TOOL - GROUP 1

STANDARD ROTIERFRÄSER - FRÄSSTIFTE / STANDARD ROTARY BURS

Form <i>Shape</i>	Schaftabmessungen <i>Shank dimensions</i>	Ident - Nr. <i>Code</i>	Seite <i>Page</i>	
KSJ-60° Kegel <i>60° Conical</i>	Ø 3,00 mm	46-60°	49	
	Standard / <i>Standard</i>	36-60°	49	
TRE Tropfen <i>Oval</i>	Ø 2,35 mm	27	50	
	Ø 3,00 mm	47	50	
	Standard / <i>Standard</i>	37	50	
	Schaftlänge / <i>Shank length</i> 100 mm	37-100	56	
	Schaftlänge / <i>Shank length</i> 150 mm	37-150	58	
Schaftlänge / <i>Shank length</i> 300 mm	37-300	60		
KUD Kugel <i>Ball</i>	Ø 2,35 mm	28	51	
	Ø 3,00 mm	48	51	
	Standard / <i>Standard</i>	38	51	
	Schaftlänge / <i>Shank length</i> 100 mm	38-100	56	
	Schaftlänge / <i>Shank length</i> 150 mm	38-150	58	
Schaftlänge / <i>Shank length</i> 300 mm	38-300	60		
WKN Winkel ohne Stirnverzahnung <i>Inverted cone without end cut</i>	Ø 3,00 mm	49	52	
	Standard / <i>Standard</i>	39	52	
WKN/ST Winkel mit Stirnverzahnung <i>Inverted cone with end cut</i>	Ø 3,00 mm	49-ST	53	
	Standard / <i>Standard</i>	39-ST	53	



01

SÄTZE & ZUBEHÖR / SETS & ACCESSORIES



		Ident - Nr. <i>Code</i>	Seite <i>Page</i>	
Sätze <i>Sets</i>	Nr. 10	10	54	
	Nr. 11	11	54	
	Nr. 12	12	54	
Druckluftschleifer <i>Air grinding unit</i>	Nr. 13	13	54	

WERKZEUG - GRUPPE 1
TOOL - GROUP 1



MATRIZENFRÄSER - WN / MOULD, TOOL AND DIE MAKING ROTARY BURS - INTERNAL STANDARD

Form Shape	Schaftabmessungen Shank dimensions	Ident - Nr. Code	Seite Page	
Zylinder Cylindrical	Zahnung 4 Cut type	40ST-4	61-62	
Zylinder Cylindrical	Zahnung 6 Cut type	40ST-6	61-62	

SPEZIAL ROTIERFRÄSER - WN / SPECIAL ROTARY BURS - INTERNAL STANDARD

Form Shape	Schaftabmessungen Shank dimensions	Ident - Nr. Code	Seite Page	
Glasnuten- Fräser Groove cutters	WN - 6,00 mm <i>Internal standard</i>	114-90°	63	
Scheiben- Radiusfräser Radius groove cutters	WN - 6,00 mm <i>Internal standard 6,00 mm</i>	115	64	
Scheiben- Zylinderfräser Disc cutters	WN - 6,00 mm <i>Internal standard 6,00 mm</i>	116	64	

Schnittgeschwindigkeiten (Richtwerte) für Cerin Frässtifte Cutting speeds (approximative values) for Cerin rotary burs

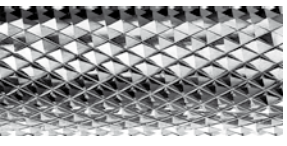
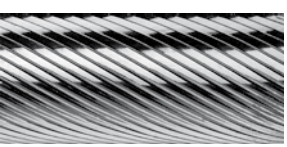
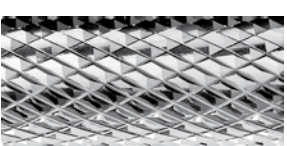
Werkstoff Material	VHM V _c (m/min)	Cer-T V _c (m/min)	Zahnung Cut type	
< 400 N/mm ²	800 - 1000	800 - 1000	Zahnung 1 Cut type 1	
< 705 N/mm ²	600 - 800	800 - 1000		
Titan Titanlegierungen	max n = 2000 (min ⁻¹)			①
< 400 N/mm ²	650 - 800	650 - 1000	Zahnung 2 Cut type 2	
< 850 N/mm ²	500 - 650	600 - 800		
Titan Titanlegierungen	max n = 2000 (min ⁻¹)			②
< 705 N/mm ²	500 - 650	600 - 800	Zahnung 3 Cut type 3	
< 1125 N/mm ²	400 - 500	400 - 600		
< 46 HRC	200 - 450	300 - 500		
Titan Titanlegierungen	max n = 2000 (min ⁻¹)			③
< 850 N/mm ²	450 - 650	500 - 750	Zahnung 4 Cut type 4	
< 1125 N/mm ²	350 - 500	400 - 600		
< 46 HRC	250 - 350	250 - 500		
< 418 HB	200 - 350	300 - 450		
Titan Titanlegierungen	max n = 2000 (min ⁻¹)			④
< 1125 N/mm ²	350 - 600	400 - 600	Zahnung 5 Cut type 5	
< 1450 N/mm ²	250 - 300	250 - 400		
< 2050 N/mm ²	150 - 250	150 - 300		
< 66HRC	150 - 300	200 - 400		
Titan Titanlegierungen	max n = 2000 (min ⁻¹)			⑤
< 705 N/mm ²	500 - 650	600 - 800	Zahnung 6 Cut type 6	
< 1125 N/mm ²	300 - 500	400 - 600		
< 46 HRC	200 - 450	300 - 500		
Titan Titanlegierungen	max n = 2000 (min ⁻¹)			⑥

* Achtung! Titan und Titanlegierungen max. n = 2000 (min⁻¹)

* Attention! Titanium and Titanium alloys max. n = 2000 (min⁻¹)

Schnittgeschwindigkeiten V_c (m/min) - Drehzahlen n (min⁻¹) Cutting speeds V_c (m/min) - Revolution per minute n (min⁻¹)

Berechnungsformeln: Schnittgeschwindigkeit V_c (m/min) - Drehzahl n (min⁻¹)

Formula: cutting speed V_c (m/min) - Revolution per minute n (min⁻¹)

$$V_c \text{ (m/min)} = \frac{\varnothing D_c \text{ (mm)} \times 3,14 \times n \text{ (min}^{-1}\text{)}}{1000}$$

$$n \text{ (min}^{-1}\text{)} = \frac{V_c \text{ (m/min)} \times 1000}{\varnothing D_c \text{ (mm)} \times 3,14}$$

V _c (m/min)	D _c (mm)									
	2,35	3,00	4,00	5,00	6,00	8,00	10,00	12,00	16,00	20,00
	Drehzahl n (min ⁻¹) / Revolution per minute n (min ⁻¹)									
100	13550	10616	7962	6369	5308	3981	3185	2654	1990	1592
150	20325	15924	11943	9554	7962	5971	4777	3981	2986	2389
200	27100	21231	15924	12739	10616	7962	6369	5308	3981	3185
250	33875	26539	19904	15924	13270	9952	7962	6635	4976	3981
300	40650	31847	23885	19108	15924	11943	9554	7962	5971	4777
350	47425	37155	27866	22293	18577	13933	11146	9289	6967	5573
400	54201	42463	31847	25478	21231	15924	12739	10616	7962	6369
500	67751	53079	39809	31847	26539	19904	15924	13270	9952	7962
600	81301	63694	47771	38217	31847	23885	19108	15924	11943	9554
700	94851	74310	55732	44586	37155	27866	22293	18577	13933	11146
800	108401	84926	63694	50955	42463	31847	25478	21231	15924	12739
900	121951	95541	71656	57325	47771	35828	28662	23885	17914	14331
1000	135501	106157	79618	63694	53079	39809	31847	26539	19904	15924

* Achtung! Titan und Titanlegierungen max. n = 2000 (min⁻¹)

* Attention! Titanium and Titanium alloys max. n = 2000 (min⁻¹)

Verzahnungen bei Cerin Frässtiften Cut types of Cerin rotary burs

Zahnung 1 - Aluminium Cut type 1 - Aluminium



Besonders geeignet für Aluminium, Magnesium, Kunststoffe, Hartholz und Hartgummi.

Gute Schnittleistung und hohe Materialabtragung. Die besondere Auslegung der Zahn- und Nutengeometrie erleichtert die Spanabfuhr und verhindert damit das Zusetzen des Werkzeuges.

Particularly suitable for working on aluminium, magnesium, plastic, and hard rubber. Gives high cutter efficiency, with good removal of material. The specific features of this type of cut facilitate rapid removal of chips preventing these from clogging the tool.

Zahnung 2 - Grob Cut type 2 - Course



Diese Verzahnung liegt zwischen der Ausführung 1 und 3. Sie eignet sich besonders für Leichtmetalle, Bronze, Messing, Zinn, Zink, Kupfer und andere, leicht zu bearbeitende Werkstoffe. Für langspanige Werkstoffe sollte diese Verzahnung mit Spanbrechernuten eingesetzt werden.

This type of cut is intermediate between cut 1 and cut 3 and, it is recommended for soft materials, bronze, brass, tin, zinc, copper and other easily removable materials. For long chipping material this cut should be used with chip breaker.

Zahnung 3 - Mittel / Standard Cut type 3 - Medium

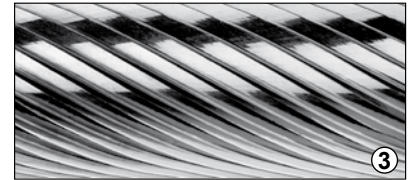

Die Standardverzahnung eignet sich für Stahl bis ca 56 HRC, Gußstahl, Stahllegierungen, Schweißnähte und fast alle metallischen Werkstoffe. Mit diesem Werkzeug werden optimale Schnittleistungen und gute Oberflächen erzielt.

Standard cut. Suitable for steel (including tempered) cast steel, weld seams, and in general almost all metallic materials. To gether with optimum efficiency, it gives a good surface finish.

Spanbrechernuten Chip breaker

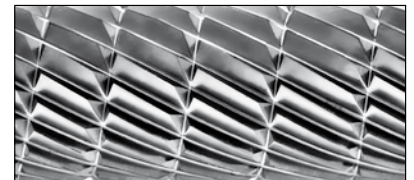

Geeignet für langspanende Werkstoffe, um kurze Späne zu erzeugen. Alle Werkzeuge mit den Verzahnungen 1-2-3-und 5 können auf Wunsch mit Spanbrechernuten zu einem geringen Aufpreis geliefert werden.

This can be executed on all single cut file cutters. Use is recommended for working of materials which produce long chips. Upon request, Cerin rotary burs with cut type 1-2-3 and 5 can be supplied with chip breaker with a small additional price.

Verzahnungen bei Cerin Frässtiften und Rotierfräsern

Cut types of Cerin rotary burs

Zahnung 4 - Diamant

Cut type 4 - Diamond

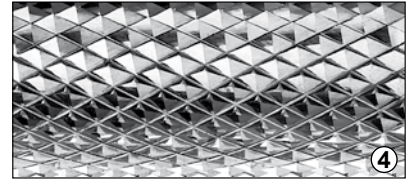

Geeignet für Grauguß, hochlegierte- rostfreie- CrNi- und Mangan-Stähle. Durch die besondere geometrische Verzahnung werden Kurz- und Kleinspäne erzeugt. Damit erfolgt eine gute Spanabfuhr und bessere Leistung als beim Standardwerkzeug.
Recommended for high alloy steel, stainless steel, magnesium alloys, grey cast iron and CrNi steels. Its particular geometry allows considerable material penetration with a removal capacity greater than the standard cut. It avoids the formation of true proper chips pulverising the removed material and thus avoiding the associated disadvantage for the operator during working.

01

Zahnung 5 - Fein

Cut type 5 - Fine

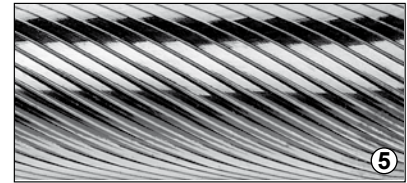

Durch die Feilverzahnung können gehärtete Stähle bis 66 HRC bearbeitet werden. Es wird eine sehr gute Oberflächengüte erzielt.
Fine cut. Particularly suitable for tempered steel up to 66 HRC and for obtaining high surface finish.

Zahnung 6 - Kreuzverzahnt

Cut type 6 - Double cut

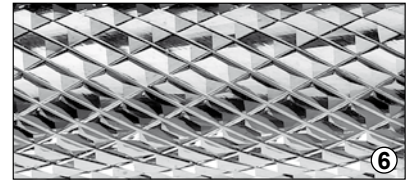

Mit dieser Universalverzahnung können fast alle Metallwerkstoffe, auch gehärtete und korrosionsbeständige Stähle, weitestgehend vibrationsarm bearbeitet werden. Es wird eine beachtliche Schnittleistung mit guter Oberflächengüte erreicht.
Universal cut suitable for working on almost metallic materials, including tempered steels and corrosion resistant material. Reduces vibration and gives a better control of the cutter during working. Considerable removal capacity with good surface finish.

Stirnverzahnung

Frontal teeth

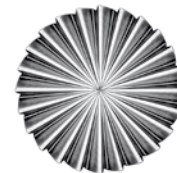







Damit kann auch frontal Material abgetragen werden.
 Cerin Frässtifte - Bestell Nummer 30ST und 39ST haben eine Stirnverzahnung.
Cerin rotary burs type 30 and 39 can be supplied with end cut upon request.
Used if frontal material has to be removed.

PIKTOGRAMME (SYMBOLS) ERKLÄRUNG
ICONS (SYMBOLS) DESCRIPTION

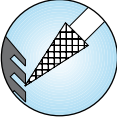
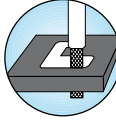
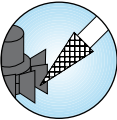
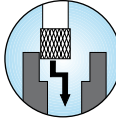
01

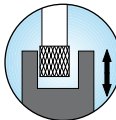
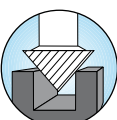
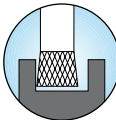
Hartmetall Qualität <i>Carbide grade</i>		Bearbeitungsbeispiel <i>Application example</i>	
Hartmetall Qualität <i>Carbide grade</i>		Bearbeitungsbeispiel <i>Application example</i>	
Baumaße ähnlich DIN 8033 <i>Dimensions similar to DIN 8033</i>		Bearbeitungsbeispiel <i>Application example</i>	
Werksnorm (WN) <i>Internal standard (WN)</i>		Bearbeitungsbeispiel <i>Application example</i>	
Werkzeug - Länge <i>Tool length</i>		Bearbeitungsbeispiel <i>Application example</i>	
Werkzeug - Länge <i>Tool length</i>		Bearbeitungsbeispiel <i>Application example</i>	
Werkzeug - Länge <i>Tool length</i>		Bearbeitungsbeispiel <i>Application example</i>	
Werkzeug - Länge <i>Tool length</i>		Bearbeitungsbeispiel <i>Application example</i>	
Achtung! Reduzierte Schnittgeschwindigkeit <i>Attention! Reduced cutting speed</i>		Bearbeitungsbeispiel <i>Application example</i>	
mit Emulsion <i>With emulsion</i>		Bearbeitungsbeispiel <i>Application example</i>	
Trockenbearbeitung <i>Dry machining</i>		Bearbeitungsbeispiel <i>Application example</i>	
mit Luft <i>With compressed air</i>		Bearbeitungsbeispiel <i>Application example</i>	
Bearbeitungsbeispiel <i>Application example</i>		Bearbeitungsbeispiel <i>Application example</i>	

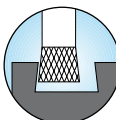
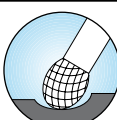
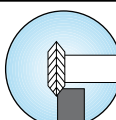
PIKTOGRAMME (SYMBOLS) ERKLÄRUNG
ICONS (SYMBOLS) DESCRIPTION

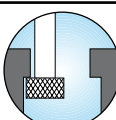
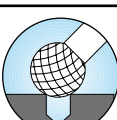
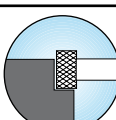
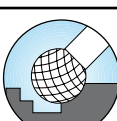
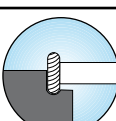
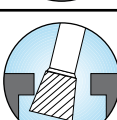
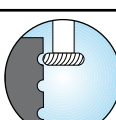
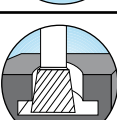
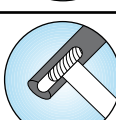
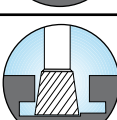
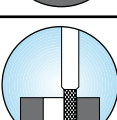
Bearbeitungsbeispiel <i>Application example</i>		Bearbeitungsbeispiel <i>Application example</i>	
Bearbeitungsbeispiel <i>Application example</i>		Bearbeitungsbeispiel <i>Application example</i>	
Bearbeitungsbeispiel <i>Application example</i>		Bearbeitungsbeispiel <i>Application example</i>	
Bearbeitungsbeispiel <i>Application example</i>		Bearbeitungsbeispiel <i>Application example</i>	
Bearbeitungsbeispiel <i>Application example</i>		Bearbeitungsbeispiel <i>Application example</i>	
Bearbeitungsbeispiel <i>Application example</i>		Bearbeitungsbeispiel <i>Application example</i>	
Bearbeitungsbeispiel <i>Application example</i>		Bearbeitungsbeispiel <i>Application example</i>	
Bearbeitungsbeispiel <i>Application example</i>		Bearbeitungsbeispiel <i>Application example</i>	
Bearbeitungsbeispiel <i>Application example</i>		Bearbeitungsbeispiel <i>Application example</i>	
Bearbeitungsbeispiel <i>Application example</i>		Bearbeitungsbeispiel <i>Application example</i>	
Bearbeitungsbeispiel <i>Application example</i>		Bearbeitungsbeispiel <i>Application example</i>	
Bearbeitungsbeispiel <i>Application example</i>			
Bearbeitungsbeispiel <i>Application example</i>			

01

Form ZYA - ohne Stirnverzahnung Shape ZYA - Cylindrical without end cut

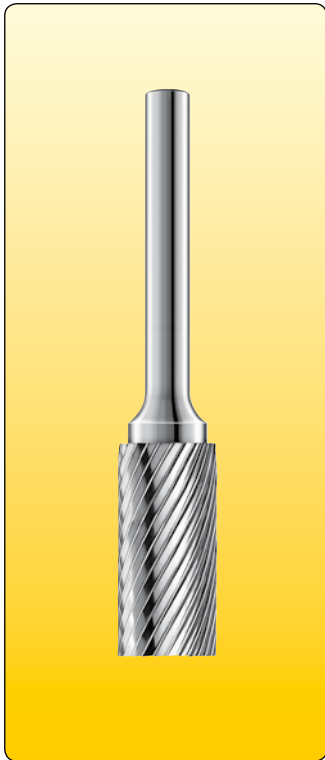

Auf Anfrage auch mit Cer-T Beschichtung lieferbar
Cer-T coating upon request

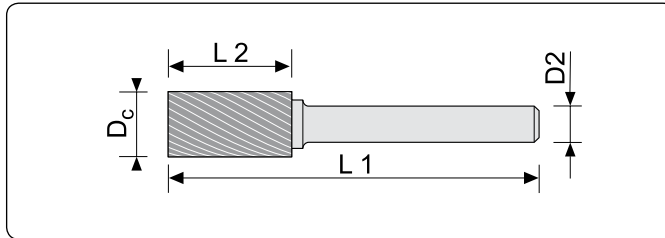

1.
01



D _c	L ₂	L ₁	D ₂	Zahnung / Cut type						20	40	30
				1	2	3	4	5	6			
1,5	8	40	2,35	-	●	●	●	●	●	2015/...		
2,35	12	40	2,35	-	●	●	●	●	●	2020/...		
4	10	45	2,35	-	●	●	●	●	●	2043/...		
5	12	47	2,35	-	●	●	●	●	●	2053/...		
6	13	48	2,35	-	●	●	●	●	●	2063/...		
1,5	8	40	3,00	-	●	●	●	●	●		4015/...	
2	10	40	3,00	-	●	●	●	●	●		4020/...	
2,5	12	40	3,00	-	●	●	●	●	●		4025/...	
3	13	40	3,00	-	●	●	●	●	●		4033/...	
4	10	45	3,00	-	●	●	●	●	●		4043/...	
5	12	47	3,00	-	●	●	●	●	●		4053/...	
6	13	48	3,00	-	●	●	●	●	●		4063/...	
4	13	50	6,00	●	●	●	●	●	●			300406/...
6	16	50	6,00	●	●	●	●	●	●			300606/...
8	20	65	6,00	●	●	●	●	●	●			300806/...
10	20	65	6,00	●	●	●	●	●	●			301006/...
12	25	70	6,00	●	●	●	●	●	●			301206/...
16	25	70	6,00	●	●	●	●	●	●			301606/...
16	25	70	8,00	●	●	●	●	●	●			301608/...
20	25	70	6,00	●	●	●	●	●	●			302006/...
20	25	70	8,00	●	●	●	●	●	●			302008/...

... Zahnung immer mit angeben (zum Beispiel: 2015/4)
... Please always indicate cut type (example: 2015/4)

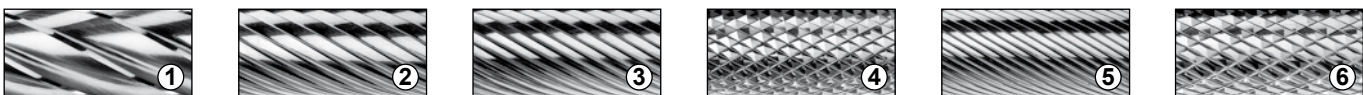

Form ZYA/ST - mit Stirnverzahnung Shape ZYA/ST - Cylindrical with end cut

1.
01



Auf Anfrage auch mit Cer-T Beschichtung lieferbar
Cer-T coating upon request

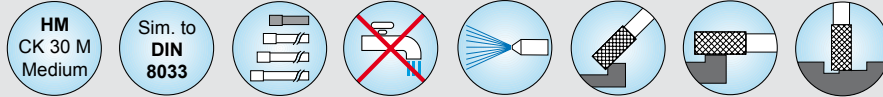
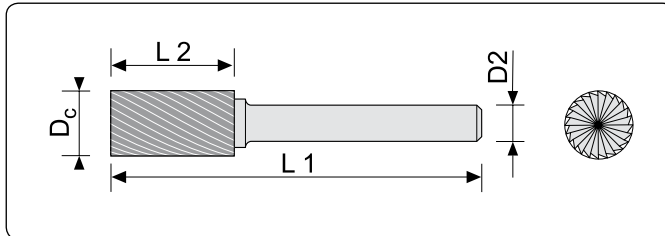

D _c	L2	L1	D2	Zahnung / Cut type						20-ST	40-ST	30-ST
				1	2	3	4	5	6			
1,5	8	40	2,35	-	●	●	●	●	●	2015/...ST		
2,35	12	40	2,35	-	●	●	●	●	●	2020/...ST		
4	10	45	2,35	-	●	●	●	●	●	2043/...ST		
5	12	47	2,35	-	●	●	●	●	●	2053/...ST		
6	13	48	2,35	-	●	●	●	●	●	2063/...ST		
1,5	8	40	3,00	-	●	●	●	●	●		4015/...ST	
2	10	40	3,00	-	●	●	●	●	●		4020/...ST	
2,5	12	40	3,00	-	●	●	●	●	●		4025/...ST	
3	13	40	3,00	-	●	●	●	●	●		4033/...ST	
4	10	45	3,00	-	●	●	●	●	●		4043/...ST	
5	12	47	3,00	-	●	●	●	●	●		4053/...ST	
6	13	48	3,00	-	●	●	●	●	●		4063/...ST	
4	13	50	6,00	●	●	●	●	●	●			300406/...ST
6	16	50	6,00	●	●	●	●	●	●			300606/...ST
8	20	65	6,00	●	●	●	●	●	●			300806/...ST
10	20	65	6,00	●	●	●	●	●	●			301006/...ST
12	25	70	6,00	●	●	●	●	●	●			301206/...ST
16	25	70	6,00	●	●	●	●	●	●			301606/...ST
16	25	70	8,00	●	●	●	●	●	●			301608/...ST
20	25	70	6,00	●	●	●	●	●	●			302006/...ST
20	25	70	8,00	●	●	●	●	●	●			302008/...ST

... Zahnung immer mit angeben (zum Beispiel: 2015/4)

... Please always indicate cut type (example: 2015/4)

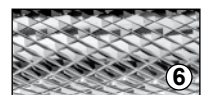
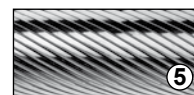
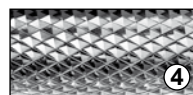
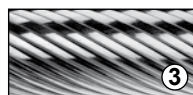
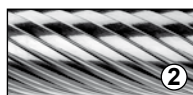

Form WRC - Walzenrund
Shape WRC - Cylindrical radius end

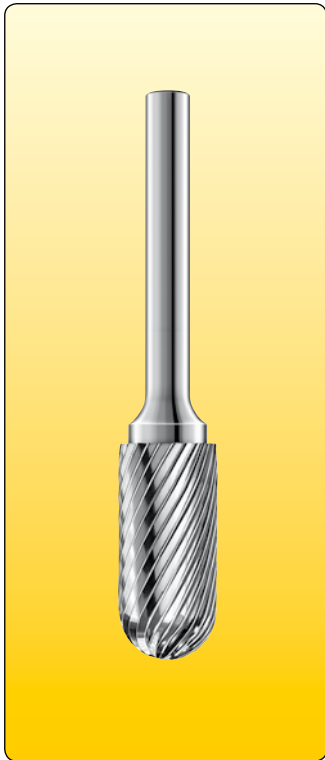

Auf Anfrage auch mit Cer-T Beschichtung lieferbar
 Cer-T coating upon request

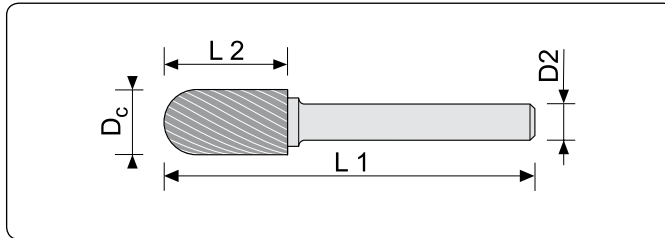

1.
01

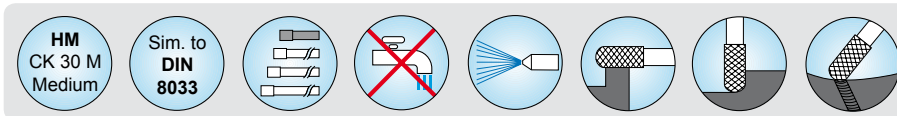

D _c	L ₂	L ₁	D ₂	Zahnung / Cut type						21	41	31
				1	2	3	4	5	6			
1,5	8	40	2,35	-	●	●	●	●	●	2115/...		
2,35	12	40	2,35	-	●	●	●	●	●	2120/...		
4	10	45	2,35	-	●	●	●	●	●	2143/...		
5	12	47	2,35	-	●	●	●	●	●	2153/...		
6	13	48	2,35	-	●	●	●	●	●	2163/...		
1,5	8	40	3,00	-	●	●	●	●	●		4115/...	
2	10	40	3,00	-	●	●	●	●	●		4120/...	
2,5	12	40	3,00	-	●	●	●	●	●		4125/...	
3	13	40	3,00	-	●	●	●	●	●		4133/...	
4	10	45	3,00	-	●	●	●	●	●		4143/...	
5	12	47	3,00	-	●	●	●	●	●		4153/...	
6	13	48	3,00	-	●	●	●	●	●		4163/...	
4	13	50	6,00	●	●	●	●	●	●			310406/...
6	16	50	6,00	●	●	●	●	●	●			310606/...
8	20	65	6,00	●	●	●	●	●	●			310806/...
10	20	65	6,00	●	●	●	●	●	●			311006/...
12	25	70	6,00	●	●	●	●	●	●			311206/...
16	25	70	6,00	●	●	●	●	●	●			311606/...
16	25	70	8,00	●	●	●	●	●	●			311608/...
20	25	70	6,00	●	●	●	●	●	●			312006/...
20	25	70	8,00	●	●	●	●	●	●			312008/...

... Zahnung immer mit angeben (zum Beispiel: 2015/4)
 ... Please always indicate cut type (example: 2015/4)

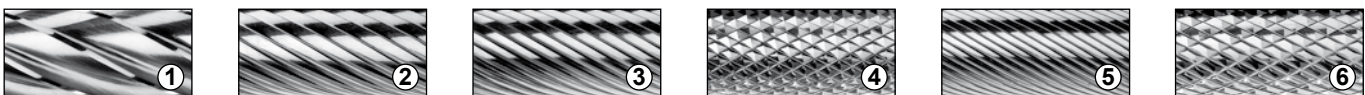

Form KEL - Rundbogen Shape KEL - Taper radius end

Auf Anfrage auch mit Cer-T Beschichtung lieferbar
Cer-T coating upon request

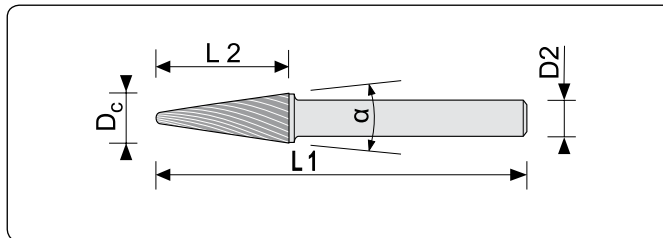
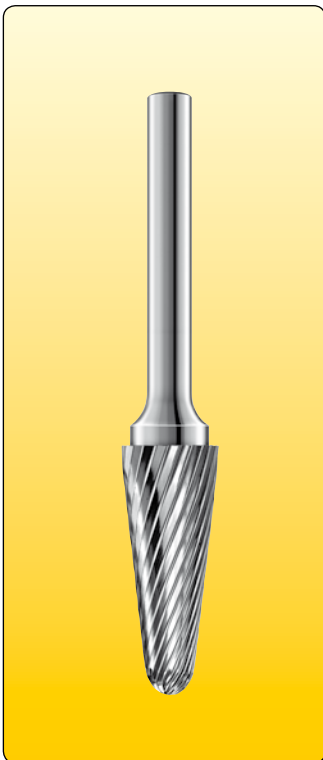

1.
01



D _c	L ₂	L ₁	D ₂	R	α	Zahnung / Cut type						22	42	32
						1	2	3	4	5	6			
2,35	12	40	2,35	1	4°	-	●	●	●	●	●	2220/...		
4	14	49	2,35	1	10°	-	●	●	●	●	●	2243/...		
5	16	51	2,35	1,5	10°	-	●	●	●	●	●	2253/...		
6	20	55	2,35	1,5	10°	-	●	●	●	●	●	2263/...		
3	14	40	3,00	1	6°	-	●	●	●	●	●		4233/...	
4	14	49	3,00	1	10°	-	●	●	●	●	●		4243/...	
5	16	51	3,00	1,5	10°	-	●	●	●	●	●		4253/...	
6	20	55	3,00	1,5	10°	-	●	●	●	●	●		4263/...	
4	14	50	6,00	1	10°	●	●	●	●	●	●			320406/...
6	20	50	6,00	1,5	10°	●	●	●	●	●	●			320606/...
8	20	65	6,00	1,5	14°	●	●	●	●	●	●			320806/...
10	20	65	6,00	2,9	14°	●	●	●	●	●	●			321006/...
12	30	75	6,00	2,6	14°	●	●	●	●	●	●			321206/...
16	30	75	6,00	4,8	14°	●	●	●	●	●	●			321606/...
16	30	75	8,00	4,8	14°	●	●	●	●	●	●			321608/...
20	42	87	6,00	5,9	14°	●	●	●	●	●	●			322006/...
20	42	87	8,00	5,9	14°	●	●	●	●	●	●			322008/...

... Zahnung immer mit angeben (zum Beispiel: 2015/4)
... Please always indicate cut type (example: 2015/4)



Form RBF - Rundbogen
Shape RBF - Tree with radius end

Auf Anfrage auch mit Cer-T Beschichtung lieferbar
 Cer-T coating upon request

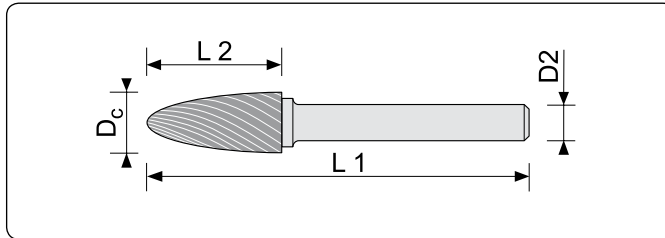
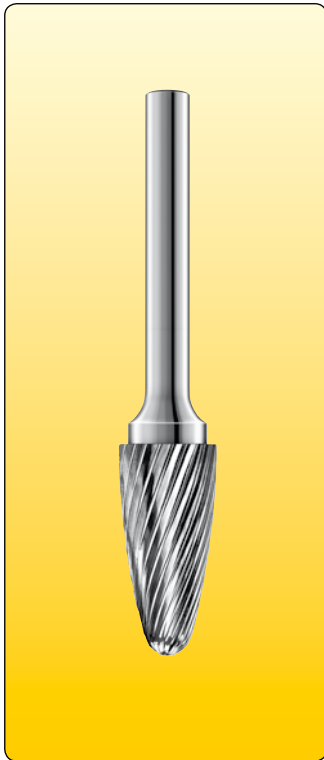

**1.
01**



D _c	L ₂	L ₁	D ₂	R~	Zahnung / Cut type						23	43	33
					1	2	3	4	5	6			
2,35	12	40	2,35	0,5	-	●	●	●	●	●	2320/...		
4	10	45	2,35	1	-	●	●	●	●	●	2343/...		
5	12	47	2,35	1,2	-	●	●	●	●	●	2353/...		
6	13	48	2,35	1,5	-	●	●	●	●	●	2363/...		
3	13	40	3,00	0,8	-	●	●	●	●	●		4333/...	
4	10	45	3,00	1	-	●	●	●	●	●		4343/...	
5	12	47	3,00	1,2	-	●	●	●	●	●		4353/...	
6	13	48	3,00	1,4	-	●	●	●	●	●		4363/...	
4	14	50	6,00	1	●	●	●	●	●	●			330406/...
6	18	50	6,00	1,5	●	●	●	●	●	●			330606/...
8	20	65	6,00	1,8	●	●	●	●	●	●			330806/...
10	20	65	6,00	2,5	●	●	●	●	●	●			331006/...
12	25	70	6,00	2,5	●	●	●	●	●	●			331206/...
16	30	75	6,00	3,6	●	●	●	●	●	●			331606/...
16	30	75	8,00	3,6	●	●	●	●	●	●			331608/...
20	35	80	6,00	5	●	●	●	●	●	●			332006/...
20	35	80	8,00	5	●	●	●	●	●	●			332008/...

... Zahnung immer mit angeben (zum Beispiel: 2015/4)
 ... Please always indicate cut type (example: 2015/4)

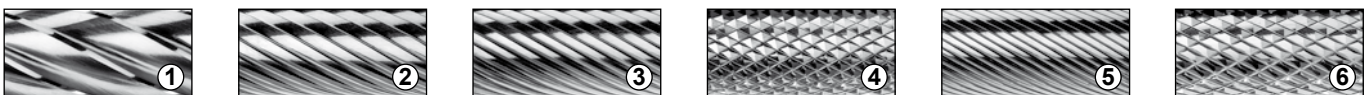

Form SPG - Spitzbogen Shape SPG - Tree with pointed end

1.
01

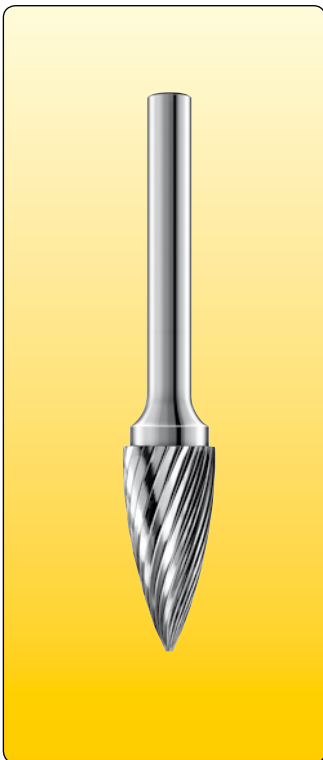

Auf Anfrage auch mit Cer-T Beschichtung lieferbar
Cer-T coating upon request

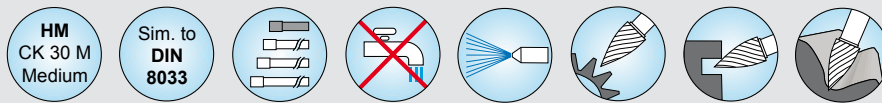
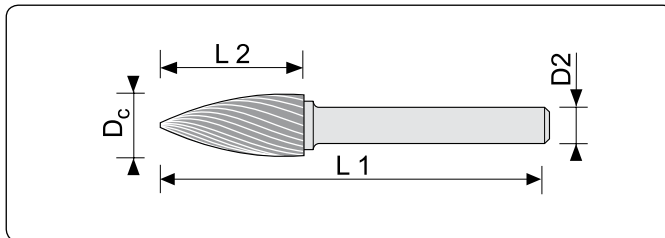

D _c	L2	L1	D2	Zahnung / Cut type						24	44	34
				1	2	3	4	5	6			
2,35	12	40	2,35	-	●	●	●	●	●	2420/...		
4	10	45	2,35	-	●	●	●	●	●	2443/...		
5	12	47	2,35	-	●	●	●	●	●	2453/...		
6	13	48	2,35	-	●	●	●	●	●	2463/...		
3	13	40	3,00	-	●	●	●	●	●		4433/...	
4	10	45	3,00	-	●	●	●	●	●		4443/...	
5	12	47	3,00	-	●	●	●	●	●		4453/...	
6	13	48	3,00	-	●	●	●	●	●		4463/...	
4	14	50	6,00	●	●	●	●	●	●			340406/...
6	18	50	6,00	●	●	●	●	●	●			340606/...
8	20	65	6,00	●	●	●	●	●	●			340806/...
10	20	65	6,00	●	●	●	●	●	●			341006/...
12	25	70	6,00	●	●	●	●	●	●			341206/...
16	30	75	6,00	●	●	●	●	●	●			341606/...
16	30	75	8,00	●	●	●	●	●	●			341608/...
20	40	85	6,00	●	●	●	●	●	●			342006/...
20	40	85	8,00	●	●	●	●	●	●			342008/...

... Zahnung immer mit angeben (zum Beispiel: 2015/4)
... Please always indicate cut type (example: 2015/4)



Form SKM - Spitzkegel
Shape SKM - Conical

Auf Anfrage auch mit Cer-T Beschichtung lieferbar
Cer-T coating upon request

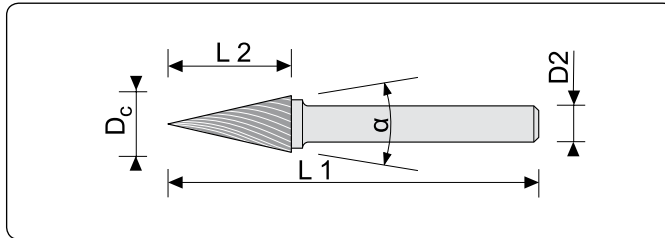
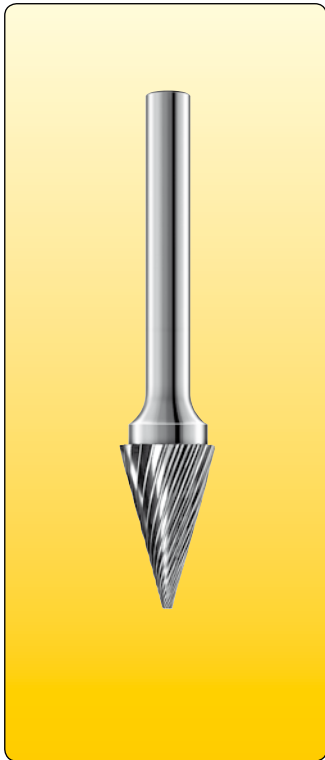

1.
01



D _c	L2	L1	D2	Zahnung / Cut type						25	45	35
				1	2	3	4	5	6			
2,35	11	40	2,35	-	●	●	●	●	●	2520/...		
4	10	45	2,35	-	●	●	●	●	●	2543/...		
5	12	47	2,35	-	●	●	●	●	●	2553/...		
6	13	48	2,35	-	●	●	●	●	●	2563/...		
3	11	40	3,00	-	●	●	●	●	●		4533/...	
4	10	45	3,00	-	●	●	●	●	●		4543/...	
5	12	47	3,00	-	●	●	●	●	●		4553/...	
6	13	48	3,00	-	●	●	●	●	●		4563/...	
4	14	50	6,00	●	●	●	●	●	●			350406/...
6	18	50	6,00	●	●	●	●	●	●			350606/...
8	20	65	6,00	●	●	●	●	●	●			350806/...
10	20	65	6,00	●	●	●	●	●	●			351006/...
12	25	70	6,00	●	●	●	●	●	●			351206/...
16	25	70	6,00	●	●	●	●	●	●			351606/...
16	25	70	8,00	●	●	●	●	●	●			351608/...
20	24	69	6,00	●	●	●	●	●	●			352006/...
20	24	69	8,00	●	●	●	●	●	●			352008/...

... Zahnung immer mit angeben (zum Beispiel: 2015/4)
 ... Please always indicate cut type (example: 2015/4)

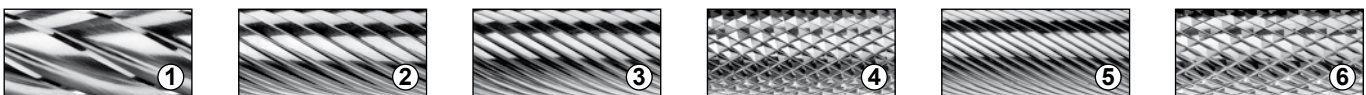

Form KSK - Kegel 90° Shape KSK - 90° Conical

1.
01

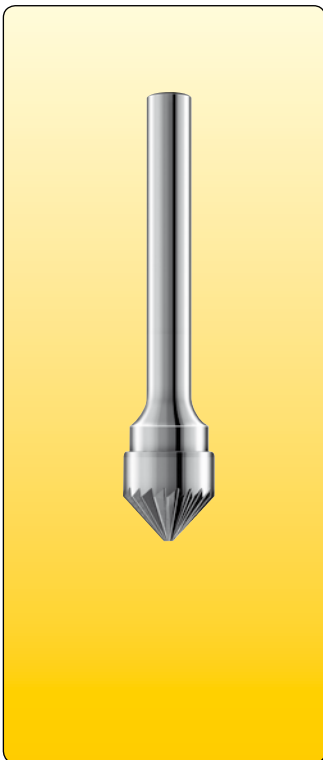

Auf Anfrage auch mit Cer-T Beschichtung lieferbar
Cer-T coating upon request

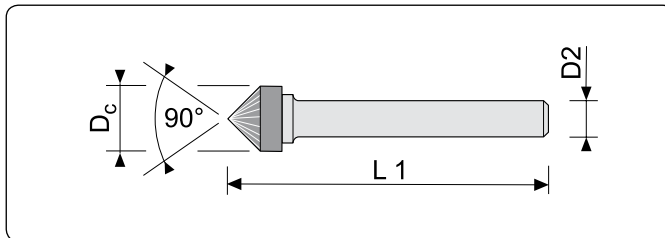

D _c	L1	D2	Zahnung / Cut type							46	36
			1	2	3	4	5	6			
3	40	3,00	-	●	●	●	●	●		4633/...-90°	
4	38	3,00	-	●	●	●	●	●		4643/...-90°	
5	39	3,00	-	●	●	●	●	●		4653/...-90°	
6	40	3,00	-	●	●	●	●	●		4663/...-90°	
4	50	6,00	●	●	●	●	●	●			360406/...-90°
6	50	6,00	●	●	●	●	●	●			360606/...-90°
8	53	6,00	●	●	●	●	●	●			360806/...-90°
10	54	6,00	●	●	●	●	●	●			361006/...-90°
12	56	6,00	●	●	●	●	●	●			361206/...-90°
16	59	6,00	●	●	●	●	●	●			361606/...-90°
20	62	6,00	●	●	●	●	●	●			362006/...-90°
20	62	8,00	●	●	●	●	●	●			362008/...-90°

... Zahnung immer mit angeben (zum Beispiel: 2015/4)
... Please always indicate cut type (example: 2015/4)



Form KSJ - Kegel 60°
Shape KSJ - 60° Conical

Auf Anfrage auch mit Cer-T Beschichtung lieferbar
Cer-T coating upon request

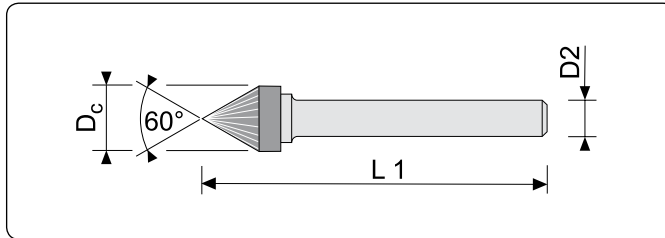
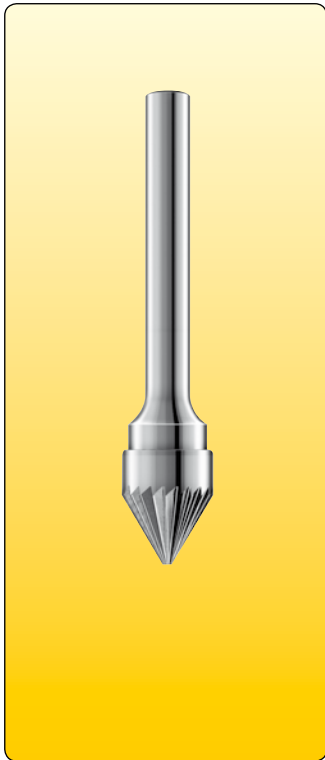

**1.
01**



D _c	L1	D2	Zahnung / Cut type						46	36
			1	2	3	4	5	6		
3	40	3,00	-	●	●	●	●	●	4633/...-60°	
4	38	3,00	-	●	●	●	●	●	4643/...-60°	
5	39	3,00	-	●	●	●	●	●	4653/...-60°	
6	40	3,00	-	●	●	●	●	●	4663/...-60°	
4	50	6,00	●	●	●	●	●	●		360406/...-60°
6	50	6,00	●	●	●	●	●	●		360606/...-60°
8	56	6,00	●	●	●	●	●	●		360806/...-60°
10	57	6,00	●	●	●	●	●	●		361006/...-60°
12	60	6,00	●	●	●	●	●	●		361206/...-60°
16	64	6,00	●	●	●	●	●	●		361606/...-60°
20	68	6,00	●	●	●	●	●	●		362006/...-60°
20	68	8,00	●	●	●	●	●	●		362008/...-60°

... Zahnung immer mit angeben (zum Beispiel: 2015/4)
 ... Please always indicate cut type (example: 2015/4)

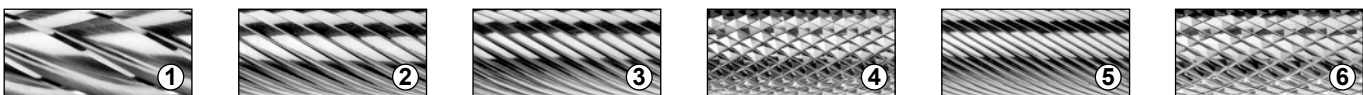

Form TRE - Tropfen Shape TRE - Oval

1.
01

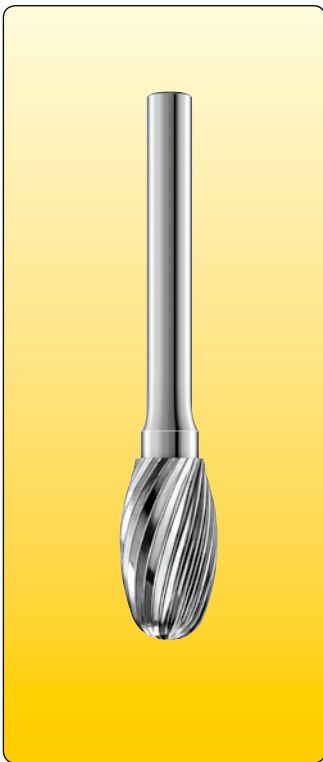

Auf Anfrage auch mit Cer-T Beschichtung lieferbar
Cer-T coating upon request

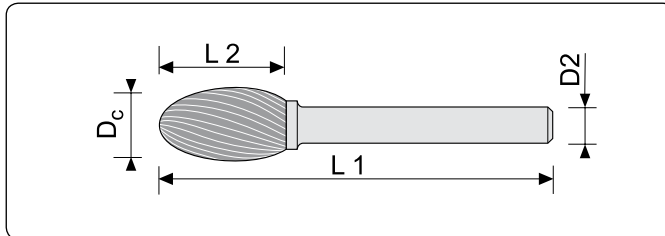

D _c	L ₂	L ₁	D ₂	R	Zahnung / Cut type						27	47	37
					1	2	3	4	5	6			
1,5	2,5	40	2,35	0,64	-	●	●	●	●	●	2715/...		
2,35	4	40	2,35	1	-	●	●	●	●	●	2720/...		
4	7	42	2,35	1,5	-	●	●	●	●	●	2743/...		
5	8	43	2,35	2	-	●	●	●	●	●	2753/...		
6	10	45	2,35	2,8	-	●	●	●	●	●	2763/...		
3	7	40	3,00	1,2	-	●	●	●	●	●		4733/...	
4	7	42	3,00	1,5	-	●	●	●	●	●		4743/...	
5	8	43	3,00	2	-	●	●	●	●	●		4753/...	
6	10	45	3,00	2,8	-	●	●	●	●	●		4763/...	
4	7	50	6,00	1,5	●	●	●	●	●	●			370406/...
6	10	50	6,00	2,8	●	●	●	●	●	●			370606/...
8	13	58	6,00	3,7	●	●	●	●	●	●			370806/...
10	16	61	6,00	4	●	●	●	●	●	●			371006/...
12	20	65	6,00	5	●	●	●	●	●	●			371206/...
16	25	70	6,00	6,5	●	●	●	●	●	●			371606/...
16	25	70	8,00	6,5	●	●	●	●	●	●			371608/...
20	25	70	6,00	9	●	●	●	●	●	●			372006/...
20	25	70	8,00	9	●	●	●	●	●	●			372008/...

... Zahnung immer mit angeben (zum Beispiel: 2015/4)
... Please always indicate cut type (example: 2015/4)

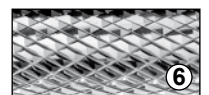
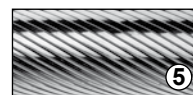
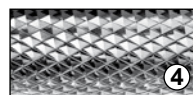
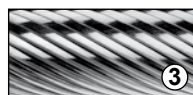

Form KUD - Kugel
Shape KUD - Ball

Auf Anfrage auch mit Cer-T Beschichtung lieferbar
Cer-T coating upon request

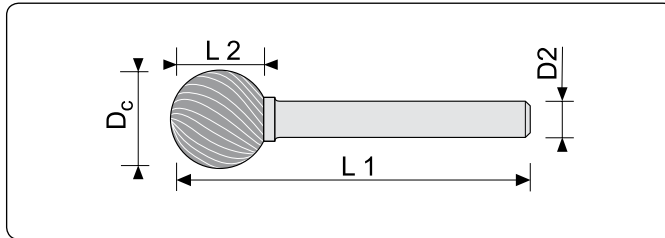

**1.
01**

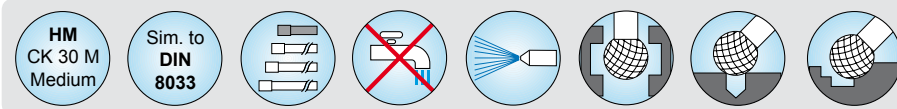

D _c	L ₂	L ₁	D ₂	Zahnung / Cut type						28	48	38
				1	2	3	4	5	6			
1,5	1,35	40	2,35		●	●	●	●	●	2815/...		
2,35	2,1	40	2,35	-	●	●	●	●	●	2820/...		
4	3,6	38,5	2,35	-	●	●	●	●	●	2843/...		
5	4,5	39,5	2,35	-	●	●	●	●	●	2853/...		
6	5,4	40,4	2,35	-	●	●	●	●	●	2863/...		
1,5	1,35	40	3,00	-	●	●	●	●	●		4815/...	
2	1,8	40	3,00	-	●	●	●	●	●		4820/...	
2,5	2,2	40	3,00	-	●	●	●	●	●		4825/...	
3	2,7	40	3,00	-	●	●	●	●	●		4833/...	
4	3,6	38,5	3,00	-	●	●	●	●	●		4843/...	
5	4,5	39,5	3,00	-	●	●	●	●	●		4853/...	
6	5,4	40,4	3,00	-	●	●	●	●	●		4863/...	
4	3,6	50	6,00	●	●	●	●	●	●			380406/...
6	5	50	6,00	●	●	●	●	●	●			380606/...
8	7,2	52,2	6,00	●	●	●	●	●	●			380806/...
10	9	54	6,00	●	●	●	●	●	●			381006/...
12	10,8	55,8	6,00	●	●	●	●	●	●			381206/...
16	14,4	59,4	6,00	●	●	●	●	●	●			381606/...
16	14,4	59,4	8,00	●	●	●	●	●	●			381608/...
20	18	63	6,00	●	●	●	●	●	●			382006/...
20	18	63	8,00	●	●	●	●	●	●			382008/...

... Zahnung immer mit angeben (zum Beispiel: 2015/4)
... Please always indicate cut type (example: 2015/4)

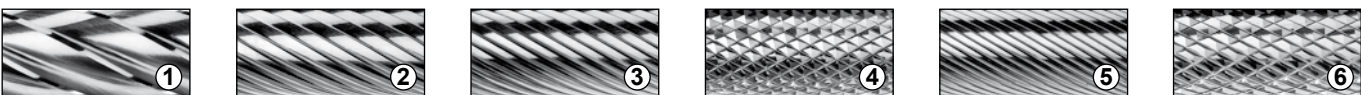

Form WKN - Winkel ohne Stirnverzahnung Shape WKN - Inverted cone without end cut

1.
01

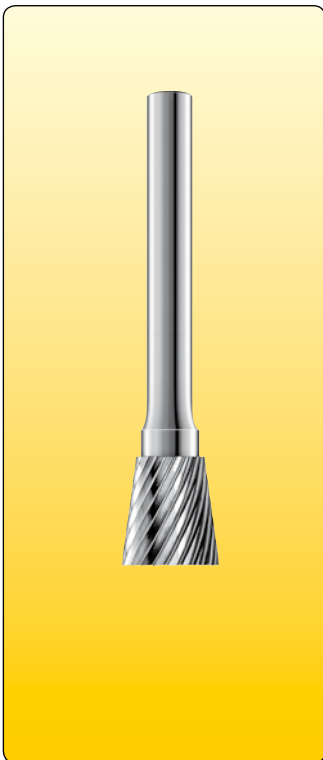

Auf Anfrage auch mit Cer-T Beschichtung lieferbar
Cer-T coating upon request

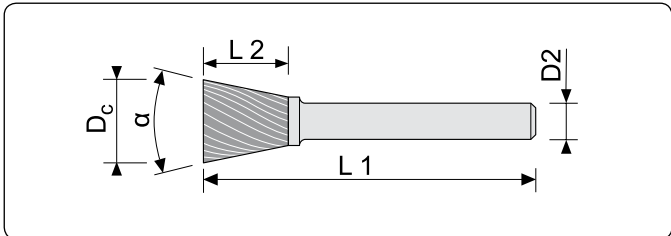

D _c	L ₂	L ₁	D ₂	α	Zahnung / Cut type						49	39
					1	2	3	4	5	6		
3	7	40	3,00	10°	-	●	●	●	●	●	4933/...	
4	7	42	3,00	10°	-	●	●	●	●	●	4943/...	
5	7	42	3,00	10°	-	●	●	●	●	●	4953/...	
6	7	42	3,00	10°	-	●	●	●	●	●	4963/...	
4	7	50	6,00	10°	●	●	●	●	●	●		390406/...
6	7	50	6,00	10°	●	●	●	●	●	●		390606/...
8	8	53	6,00	10°	●	●	●	●	●	●		390806/...
10	13	58	6,00	10°	●	●	●	●	●	●		391006/...
12	13	58	6,00	20°	●	●	●	●	●	●		391206/...
16	13	58	6,00	20°	●	●	●	●	●	●		391606/...
20	13	58	6,00	30°	●	●	●	●	●	●		392006/...
20	13	58	8,00	30°	●	●	●	●	●	●		392008/...

... Zahnung immer mit angeben (zum Beispiel: 2015/4)
... Please always indicate cut type (example: 2015/4)

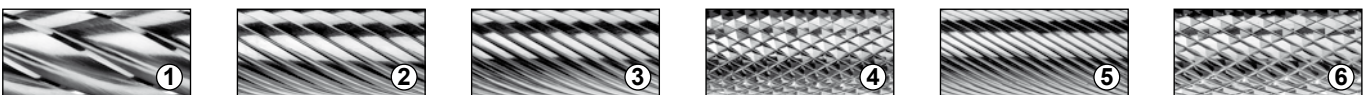

Form WKN/ST - Winkel mit Stirnverzahnung
Shape WKN/ST - Inverted cone with end cut

Auf Anfrage auch mit Cer-T Beschichtung lieferbar
 Cer-T coating upon request

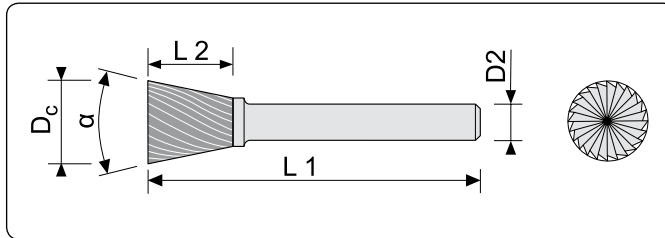
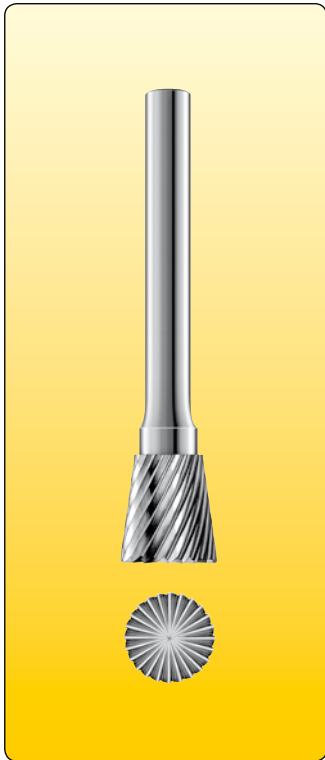

**1.
01**

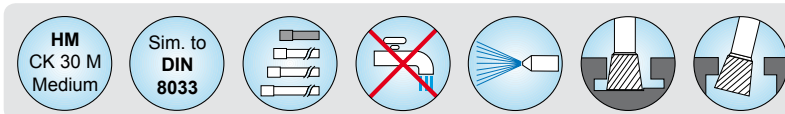

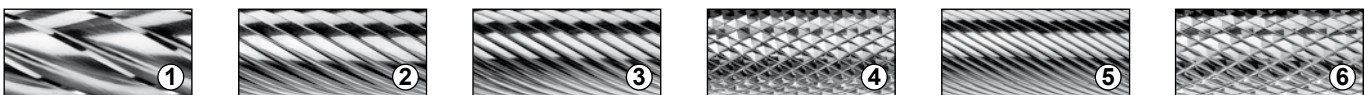

D _c	L ₂	L ₁	D ₂	α	Zahnung / Cut type						49-ST	39-ST
					1	2	3	4	5	6		
3	7	40	3,00	10°	-	●	●	●	●	●	4933/...ST	
4	7	42	3,00	10°	-	●	●	●	●	●	4943/...ST	
5	7	42	3,00	10°	-	●	●	●	●	●	4953/...ST	
6	7	42	3,00	10°	-	●	●	●	●	●	4963/...ST	
4	7	50	6,00	10°	●	●	●	●	●	●		390406/...ST
6	7	50	6,00	10°	●	●	●	●	●	●		390606/...ST
8	8	53	6,00	10°	●	●	●	●	●	●		390806/...ST
10	13	58	6,00	10°	●	●	●	●	●	●		391006/...ST
12	13	58	6,00	20°	●	●	●	●	●	●		391206/...ST
16	13	58	6,00	20°	●	●	●	●	●	●		391606/...ST
20	13	58	6,00	30°	●	●	●	●	●	●		392006/...ST
20	13	58	8,00	30°	●	●	●	●	●	●		392008/...ST

... Zahnung immer mit angeben (zum Beispiel: 2015/4)
 ... Please always indicate cut type (example: 2015/4)



Sätze & Zubehör Sets & Accessories

Satz / Set	Nr. 10		<p>Satz Nr. 10 - bestehend aus: 4033 - 4133 - 4233 - 4333 - 4433 - 4533 - 4633 - 4733 - 4833 - 4933 Lieferbar in Zahnung Typ 3-4-5-6</p> <p><i>Set Nr. 10 - including:</i> 4033 - 4133 - 4233 - 4333 - 4433 - 4533 - 4633 - 4733 - 4833 - 4933 Available in cut type 3-4-5-6</p>
Satz / Set	Nr. 11		<p>Satz Nr. 11 - bestehend aus: 4063 - 4163 - 4263 - 4363 - 4463 - 4563 - 4663 - 4763 - 4863 - 4963 Lieferbar in Zahnung Typ 2-3-4-5-6</p> <p><i>Set Nr. 11 - including:</i> 4063 - 4163 - 4263 - 4363 - 4463 - 4563 - 4663 - 4763 - 4863 - 4963 Available in cut type 2-3-4-5-6</p>
Satz / Set	Nr. 12		<p>Satz Nr. 12 - bestehend aus: 300606 - 310606 - 320606 - 330606 - 340606 - 350606 - 360606 - 370606 - 380606 - 390606 Lieferbar in Zahnung Typ 1-2-3-4-5-6</p> <p><i>Set Nr. 12 - including:</i> 300606 - 310606 - 320606 - 330606 - 340606 - 350606 - 360606 - 370606 - 380606 - 390606 Available in cut type 1-2-3-4-5-6</p>

1.
01

DRUCKLUFTSCHLEIFER Drehzahl: 24.000 min⁻¹ - Luftverbrauch: 250 l/min AIR GRINDING UNIT 24.000 min⁻¹ - Air consumption: 250 l/min

Satz / Set	Nr. 13		 <p>Satz Nr. 13 - bestehend aus: 301206/1 - 311206/2 - 321206/3 - 331206/4 - 341206/5 - 351206/3SP - 361206/3 - 371206/3 - 381206/6 - 391206/3 SMS 30 DC</p> <p><i>Set Nr. 13 - including:</i> 301206/1 - 311206/2 - 321206/3 - 331206/4 - 341206/5 - 351206/3SP - 361206/3 - 371206/3 - 381206/6 - 391206/3 SMS 30 DC</p>
------------	--------	---	---

Frässtifte - Schaftlänge 100 mm Rotary burs shank length 100 mm

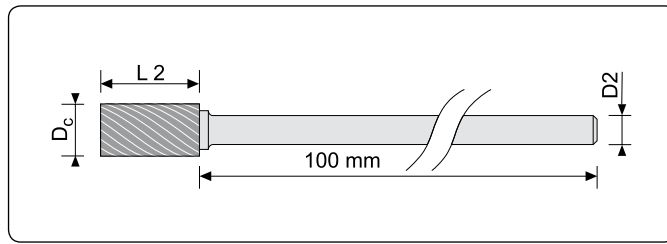
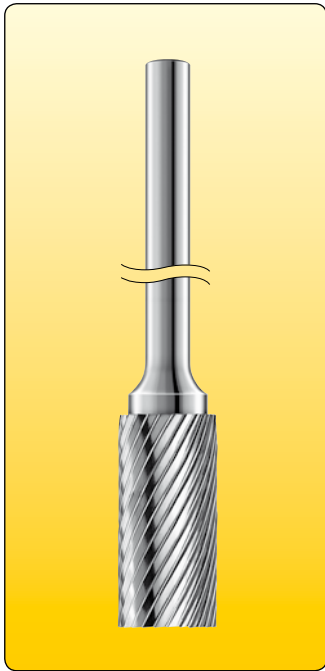





HM
CK 30 M
Medium

WN



1.
02

D _c	L2	D2	Zahnung / Cut type						Bestell - Nummer Order code	Ausführung Design
			1	2	3	4	5	6		
6	18	6	-	-	●	●	-	●	300606/...x100	Form - Shape ZYA Ident. 30 
8	20	6	-	-	●	●	-	●	300806/...x100	
10	20	6	-	-	●	●	-	●	301006/...x100	
12	25	6	-	-	●	●	-	●	301206/...x100	
16	25	6	-	-	●	●	-	●	301606/...x100	
16	25	8	-	-	●	●	-	●	301608/...x100	
20	25	6	-	-	●	●	-	●	302006/...x100	
20	25	8	-	-	●	●	-	●	302008/...x100	
6	18	6	-	-	●	●	-	●	300606/...STx100	Form - Shape ZYA-ST Ident. 30-ST 
8	20	6	-	-	●	●	-	●	300806/...STx100	
10	20	6	-	-	●	●	-	●	301006/...STx100	
12	25	6	-	-	●	●	-	●	301206/...STx100	
16	25	6	-	-	●	●	-	●	301606/...STx100	
16	25	8	-	-	●	●	-	●	301608/...STx100	
20	25	6	-	-	●	●	-	●	302006/...STx100	
20	25	8	-	-	●	●	-	●	302008/...STx100	
6	18	6	-	-	●	●	-	●	310606/...x100	Form - Shape WRC Ident. 31 
8	20	6	-	-	●	●	-	●	310806/...x100	
10	20	6	-	-	●	●	-	●	311006/...x100	
12	25	6	-	-	●	●	-	●	311206/...x100	
16	25	6	-	-	●	●	-	●	311606/...x100	
16	25	8	-	-	●	●	-	●	311608/...x100	
20	25	6	-	-	●	●	-	●	312006/...x100	
20	25	8	-	-	●	●	-	●	312008/...x100	
6	20	6	-	-	●	●	-	●	320606/...x100	Form - Shape KEL-14° Ident. 32 
8	20	6	-	-	●	●	-	●	320806/...x100	
10	20	6	-	-	●	●	-	●	321006/...x100	
12	30	6	-	-	●	●	-	●	321206/...x100	
16	30	6	-	-	●	●	-	●	321606/...x100	
16	30	8	-	-	●	●	-	●	321608/...x100	
20	42	6	-	-	●	●	-	●	322006/...x100	
20	42	8	-	-	●	●	-	●	322008/...x100	

... Zahnung immer mit angeben (zum Beispiel: 2015/4)

... Please always indicate cut type (example: 2015/4)

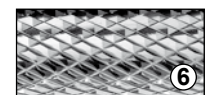
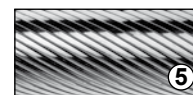
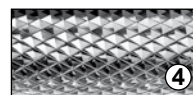
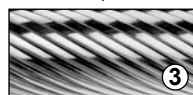

Frässtifte - Schaftlänge 100 mm Rotary burs shank length 100 mm

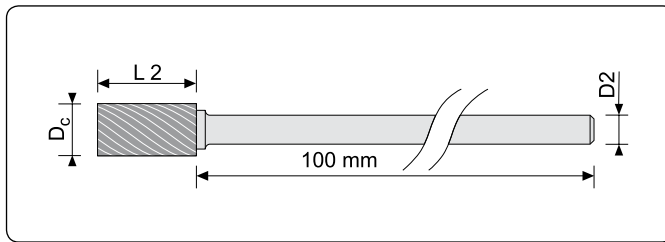
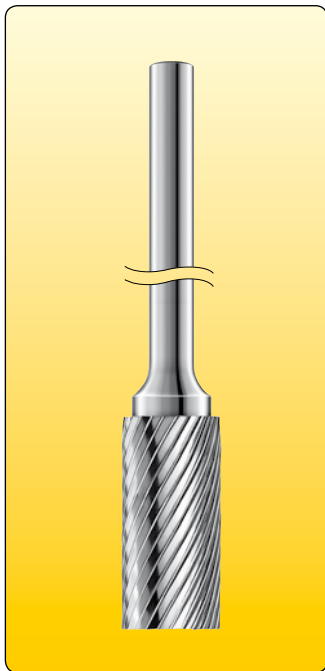

1.
02

D _c	L2	D2	Zahnung / Cut type						Bestell - Nummer Order code	Ausführung Design	
			1	2	3	4	5	6			
6	18	6	-	-	●	●	-	●	330606/...x100	Form - Shape RBF	Ident. 33
8	20	6	-	-	●	●	-	●	330806/...x100		
10	20	6	-	-	●	●	-	●	331006/...x100		
12	25	6	-	-	●	●	-	●	331206/...x100		
16	30	6	-	-	●	●	-	●	331606/...x100		
16	30	8	-	-	●	●	-	●	331608/...x100		
20	35	6	-	-	●	●	-	●	332006/...x100		
20	35	8	-	-	●	●	-	●	332008/...x100		
6	18	6	-	-	●	●	-	●	340606/...x100	Form - Shape SPG	Ident. 34
8	20	6	-	-	●	●	-	●	340806/...x100		
10	20	6	-	-	●	●	-	●	341006/...x100		
12	25	6	-	-	●	●	-	●	341206/...x100		
16	30	6	-	-	●	●	-	●	341606/...x100		
16	30	8	-	-	●	●	-	●	341608/...x100		
20	40	6	-	-	●	●	-	●	342006/...x100		
20	40	8	-	-	●	●	-	●	342008/...x100		
6	20	6	-	-	●	●	-	●	370606/...x100	Form - Shape TRE	Ident. 37
8	13	6	-	-	●	●	-	●	370806/...x100		
10	16	6	-	-	●	●	-	●	371006/...x100		
12	20	6	-	-	●	●	-	●	371206/...x100		
16	25	6	-	-	●	●	-	●	371606/...x100		
16	25	8	-	-	●	●	-	●	371608/...x100		
20	25	6	-	-	●	●	-	●	372006/...x100		
20	25	8	-	-	●	●	-	●	372008/...x100		
6	5,4	6	-	-	●	●	-	●	380606/...x100	Form - Shape KUD	Ident. 38
8	7,2	6	-	-	●	●	-	●	380806/...x100		
10	9	6	-	-	●	●	-	●	381006/...x100		
12	10,8	6	-	-	●	●	-	●	381206/...x100		
16	14,4	6	-	-	●	●	-	●	381606/...x100		
16	14,4	8	-	-	●	●	-	●	381608/...x100		
20	18	6	-	-	●	●	-	●	382006/...x100		
20	18	8	-	-	●	●	-	●	382008/...x100		

... Zahnung immer mit angeben (zum Beispiel: 2015/4)

... Please always indicate cut type (example: 2015/4)

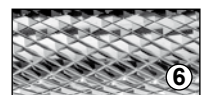
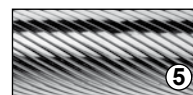
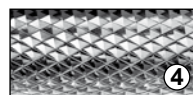
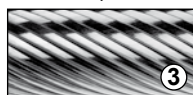

Frässtifte - Schaftlänge 150 mm Rotary burs shank length 150 mm

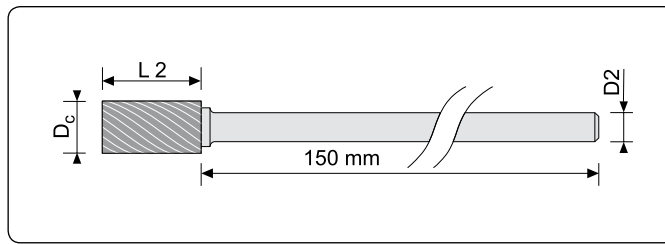
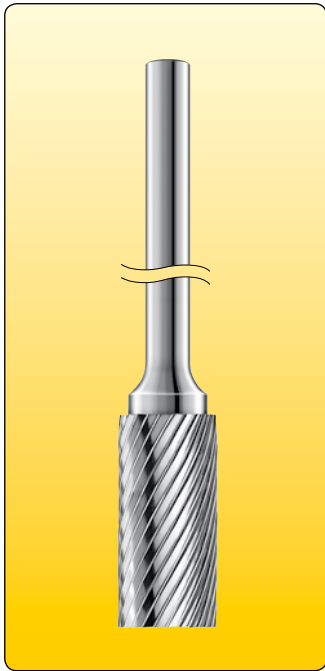

HM
CK 30 M
Medium

WN



1.
02

D _c	L2	D2	Zahnung / Cut type						Bestell - Nummer Order code	Ausführung Design	
			1	2	3	4	5	6			
6	18	6	-	-	●	●	-	●	300606/...x150	Form - Shape ZYA	Ident. 30
8	20	6	-	-	●	●	-	●	300806/...x150		
10	20	6	-	-	●	●	-	●	301006/...x150		
12	25	6	-	-	●	●	-	●	301206/...x150		
16	25	6	-	-	●	●	-	●	301606/...x150		
16	25	8	-	-	●	●	-	●	301608/...x150		
20	25	6	-	-	●	●	-	●	302006/...x150		
20	25	8	-	-	●	●	-	●	302008/...x150		
6	18	6	-	-	●	●	-	●	300606/...STx150	Form - Shape ZYA-ST	Ident. 30-ST
8	20	6	-	-	●	●	-	●	300806/...STx150		
10	20	6	-	-	●	●	-	●	301006/...STx150		
12	25	6	-	-	●	●	-	●	301206/...STx150		
16	25	6	-	-	●	●	-	●	301606/...STx150		
16	25	8	-	-	●	●	-	●	301608/...STx150		
20	25	6	-	-	●	●	-	●	302006/...STx150		
20	25	8	-	-	●	●	-	●	302008/...STx150		
6	18	6	-	-	●	●	-	●	310606/...x150	Form - Shape WRC	Ident. 31
8	20	6	-	-	●	●	-	●	310806/...x150		
10	20	6	-	-	●	●	-	●	311006/...x150		
12	25	6	-	-	●	●	-	●	311206/...x150		
16	25	6	-	-	●	●	-	●	311606/...x150		
16	25	8	-	-	●	●	-	●	311608/...x150		
20	25	6	-	-	●	●	-	●	312006/...x150		
20	25	8	-	-	●	●	-	●	312008/...x150		
6	20	6	-	-	●	●	-	●	320606/...x150	Form - Shape KEL-14°	Ident. 32
8	20	6	-	-	●	●	-	●	320806/...x150		
10	20	6	-	-	●	●	-	●	321006/...x150		
12	30	6	-	-	●	●	-	●	321206/...x150		
16	30	6	-	-	●	●	-	●	321606/...x150		
16	30	8	-	-	●	●	-	●	321608/...x150		
20	42	6	-	-	●	●	-	●	322006/...x150		
20	42	8	-	-	●	●	-	●	322008/...x150		

... Zahnung immer mit angeben (zum Beispiel: 2015/4)

... Please always indicate cut type (example: 2015/4)

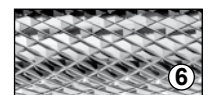
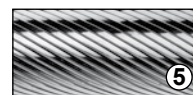
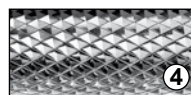
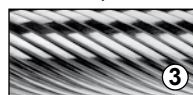

Frässtifte - Schaftlänge 150 mm Rotary burs shank length 150 mm

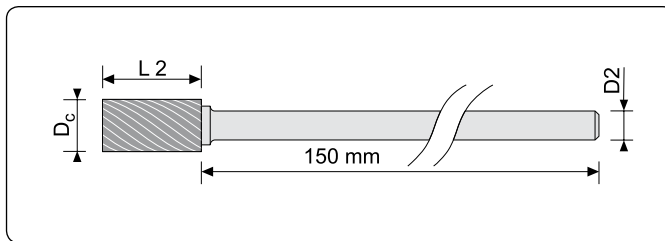
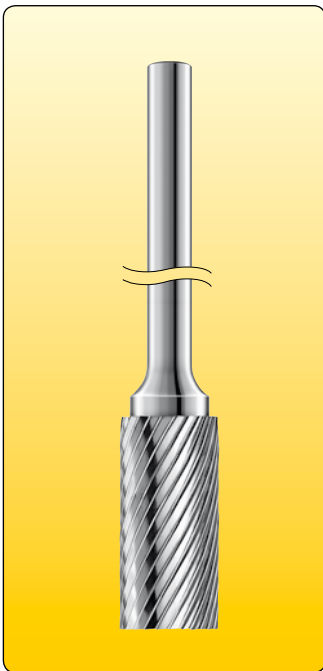

1.
02

D _c	L2	D2	Zahnung / Cut type						Bestell - Nummer Order code	Ausführung Design	
			1	2	3	4	5	6			
6	18	6	-	-	●	●	-	●	330606/...x150	Form - Shape RBF	Ident. 33
8	20	6	-	-	●	●	-	●	330806/...x150		
10	20	6	-	-	●	●	-	●	331006/...x150		
12	25	6	-	-	●	●	-	●	331206/...x150		
16	30	6	-	-	●	●	-	●	331606/...x150		
16	30	8	-	-	●	●	-	●	331608/...x150		
20	35	6	-	-	●	●	-	●	332006/...x150		
20	35	8	-	-	●	●	-	●	332008/...x150		
6	18	6	-	-	●	●	-	●	344606/...x150	Form - Shape SPG	Ident. 34
8	20	6	-	-	●	●	-	●	344806/...x150		
10	20	6	-	-	●	●	-	●	341006/...x150		
12	25	6	-	-	●	●	-	●	341206/...x150		
16	30	6	-	-	●	●	-	●	341606/...x150		
16	30	8	-	-	●	●	-	●	341608/...x150		
20	40	6	-	-	●	●	-	●	342006/...x150		
20	40	8	-	-	●	●	-	●	342008/...x150		
6	20	6	-	-	●	●	-	●	370606/...x150	Form - Shape TRE	Ident. 37
8	13	6	-	-	●	●	-	●	370806/...x150		
10	16	6	-	-	●	●	-	●	371006/...x150		
12	20	6	-	-	●	●	-	●	371206/...x150		
16	25	6	-	-	●	●	-	●	371606/...x150		
16	25	8	-	-	●	●	-	●	371608/...x150		
20	25	6	-	-	●	●	-	●	372006/...x150		
20	25	8	-	-	●	●	-	●	372008/...x150		
6	5,4	6	-	-	●	●	-	●	380606/...x150	Form - Shape KUD	Ident. 38
8	7,2	6	-	-	●	●	-	●	380806/...x150		
10	9	6	-	-	●	●	-	●	381006/...x150		
12	10,8	6	-	-	●	●	-	●	381206/...x150		
16	14,4	6	-	-	●	●	-	●	381606/...x150		
16	14,4	8	-	-	●	●	-	●	381608/...x150		
20	18	6	-	-	●	●	-	●	382006/...x150		
20	18	8	-	-	●	●	-	●	382008/...x150		

... Zahnung immer mit angeben (zum Beispiel: 2015/4)

... Please always indicate cut type (example: 2015/4)

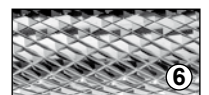
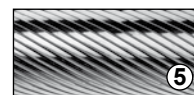
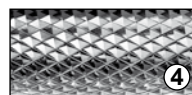
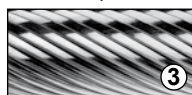



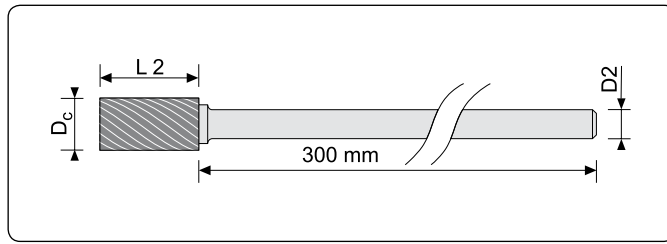
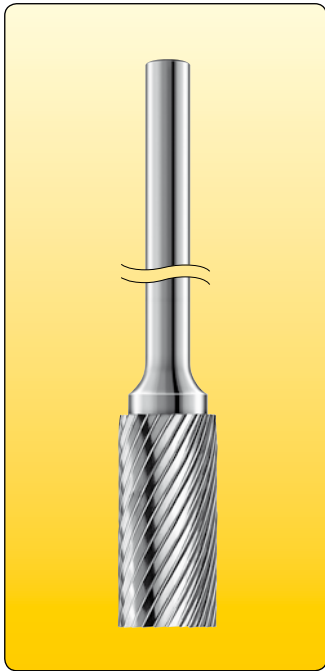

Frässtifte - Schaftlänge 300 mm
Rotary burs shank length 300 mm



Material and performance icons: HM CK 30 M Medium, WN, a burr icon, and Vc -30%.

**1.
02**

D _c	L2	D2	Zahnung / Cut type						Bestell - Nummer Order code	Ausführung Design
			1	2	3	4	5	6		
6	18	6	-	-	●	●	-	●	300606/...x300	Form - Shape ZYA Ident. 30 
8	20	6	-	-	●	●	-	●	300806/...x300	
10	20	6	-	-	●	●	-	●	301006/...x300	
12	25	6	-	-	●	●	-	●	301206/...x300	
16	25	6	-	-	●	●	-	●	301606/...x300	
16	25	8	-	-	●	●	-	●	301608/...x300	
20	25	6	-	-	●	●	-	●	302006/...x300	
20	25	8	-	-	●	●	-	●	302008/...x300	
6	18	6	-	-	●	●	-	●	300606/...STx300	Form - Shape ZYA-ST Ident. 30-ST 
8	20	6	-	-	●	●	-	●	300806/...STx300	
10	20	6	-	-	●	●	-	●	301006/...STx300	
12	25	6	-	-	●	●	-	●	301206/...STx300	
16	25	6	-	-	●	●	-	●	301606/...STx300	
16	25	8	-	-	●	●	-	●	301608/...STx300	
20	25	6	-	-	●	●	-	●	302006/...STx300	
20	25	8	-	-	●	●	-	●	302008/...STx300	
6	18	6	-	-	●	●	-	●	310606/...x300	Form - Shape WRC Ident. 31 
8	20	6	-	-	●	●	-	●	310806/...x300	
10	20	6	-	-	●	●	-	●	311006/...x300	
12	25	6	-	-	●	●	-	●	311206/...x300	
16	25	6	-	-	●	●	-	●	311606/...x300	
16	25	8	-	-	●	●	-	●	311608/...x300	
20	25	6	-	-	●	●	-	●	312006/...x300	
20	25	8	-	-	●	●	-	●	312008/...x300	
6	20	6	-	-	●	●	-	●	320606/...x300	Form - Shape KEL-14° Ident. 32 
8	20	6	-	-	●	●	-	●	320806/...x300	
10	20	6	-	-	●	●	-	●	321006/...x300	
12	30	6	-	-	●	●	-	●	321206/...x300	
16	30	6	-	-	●	●	-	●	321606/...x300	
16	30	8	-	-	●	●	-	●	321608/...x300	
20	42	6	-	-	●	●	-	●	322006/...x300	
20	42	8	-	-	●	●	-	●	322008/...x300	

... Zahnung immer mit angeben (zum Beispiel: 2015/4)

... Please always indicate cut type (example: 2015/4)



Frässtifte - Schaftlänge 300 mm Rotary burs shank length 300 mm

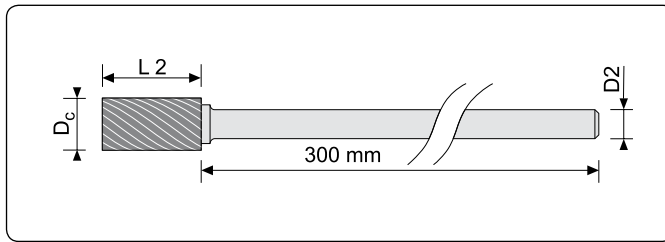
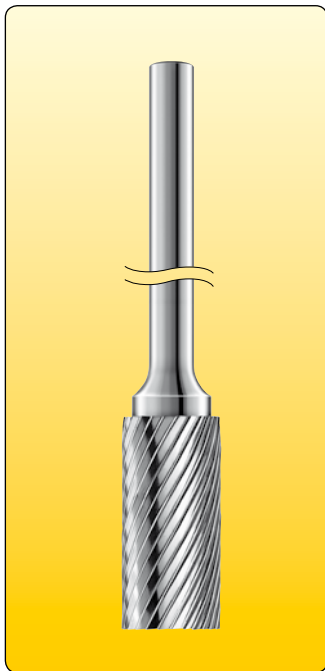

HM
CK 30 M
Medium

WN



Vc
-30%

1.
02

D _c	L2	D2	Zahnung / Cut type						Bestell - Nummer Order code	Ausführung Design	
			1	2	3	4	5	6			
6	18	6	-	-	●	●	-	●	330606/...x300	Form - Shape RBF	Ident. 33
8	20	6	-	-	●	●	-	●	330806/...x300		
10	20	6	-	-	●	●	-	●	331006/...x300		
12	25	6	-	-	●	●	-	●	331206/...x300		
16	30	6	-	-	●	●	-	●	331606/...x300		
16	30	8	-	-	●	●	-	●	331608/...x300		
20	35	6	-	-	●	●	-	●	332006/...x300		
20	35	8	-	-	●	●	-	●	332008/...x300		
6	18	6	-	-	●	●	-	●	340606/...x300	Form - Shape SPG	Ident. 34
8	20	6	-	-	●	●	-	●	340806/...x300		
10	20	6	-	-	●	●	-	●	341006/...x300		
12	25	6	-	-	●	●	-	●	341206/...x300		
16	30	6	-	-	●	●	-	●	341606/...x300		
16	30	8	-	-	●	●	-	●	341608/...x300		
20	40	6	-	-	●	●	-	●	342006/...x300		
20	40	8	-	-	●	●	-	●	342008/...x300		
6	20	6	-	-	●	●	-	●	370606/...x300	Form - Shape TRE	Ident. 37
8	13	6	-	-	●	●	-	●	370806/...x300		
10	16	6	-	-	●	●	-	●	371006/...x300		
12	20	6	-	-	●	●	-	●	371206/...x300		
16	25	6	-	-	●	●	-	●	371606/...x300		
16	25	8	-	-	●	●	-	●	371608/...x300		
20	25	6	-	-	●	●	-	●	372006/...x300		
20	25	8	-	-	●	●	-	●	372008/...x300		
6	5,4	6	-	-	●	●	-	●	380606/...x300	Form - Shape KUD	Ident. 38
8	7,2	6	-	-	●	●	-	●	380806/...x300		
10	9	6	-	-	●	●	-	●	381006/...x300		
12	10,8	6	-	-	●	●	-	●	381206/...x300		
16	14,4	6	-	-	●	●	-	●	381606/...x300		
16	14,4	8	-	-	●	●	-	●	381608/...x300		
20	18	6	-	-	●	●	-	●	382006/...x300		
20	18	8	-	-	●	●	-	●	382008/...x300		

... Zahnung immer mit angeben (zum Beispiel: 2015/4)

... Please always indicate cut type (example: 2015/4)

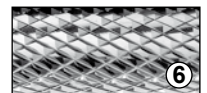
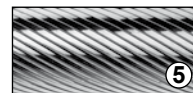
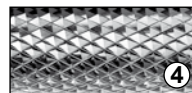
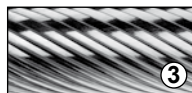

Matrizenfrässtifte mit Stirnverzahnung
Mould, tool and die making rotary burs with end cut



Auf Anfrage auch mit Cer-T Beschichtung lieferbar
 Cer-T coating upon request

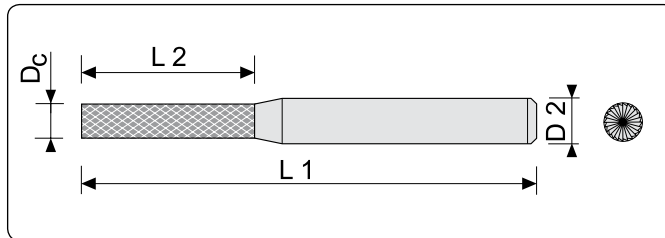

1.
03

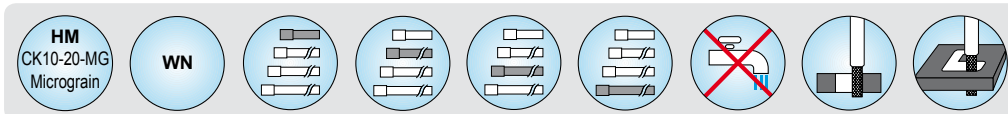

D _c	L2	L1	D2	Zahnung / Cut type						Zahnung 4 Cut type 4	Zahnung 6 Cut type 6
				1	2	3	4	5	6		
1	6	50	3,00	-	-	-	●	-	●	4010/4STx050	4010/6STx050
1	6	65	3,00	-	-	-	●	-	●	4010/4STx065	4010/6STx065
1	6	70	3,00	-	-	-	●	-	●	4010/4STx070	4010/6STx070
1	6	80	3,00	-	-	-	●	-	●	4010/4STx080	4010/6STx080
1	6	90	3,00	-	-	-	●	-	●	4010/4STx090	4010/6STx090
1	6	100	3,00	-	-	-	●	-	●	4010/4STx100	4010/6STx100
1,5	8	50	3,00	-	-	-	●	-	●	4015/4STx050	4015/6STx050
1,5	8	65	3,00	-	-	-	●	-	●	4015/4STx065	4015/6STx065
1,5	8	70	3,00	-	-	-	●	-	●	4015/4STx070	4015/6STx070
1,5	8	80	3,00	-	-	-	●	-	●	4015/4STx080	4015/6STx080
1,5	8	90	3,00	-	-	-	●	-	●	4015/4STx090	4015/6STx090
1,5	8	100	3,00	-	-	-	●	-	●	4015/4STx100	4015/6STx100
2	10	50	3,00	-	-	-	●	-	●	4020/4STx050	4020/6STx050
2	10	65	3,00	-	-	-	●	-	●	4020/4STx065	4020/6STx065
2	10	70	3,00	-	-	-	●	-	●	4020/4STx070	4020/6STx070
2	10	80	3,00	-	-	-	●	-	●	4020/4STx080	4020/6STx080
2	10	90	3,00	-	-	-	●	-	●	4020/4STx090	4020/6STx090
2	10	100	3,00	-	-	-	●	-	●	4020/4STx100	4020/6STx100

... Zahnung immer mit angeben (zum Beispiel: 2015/4)

... Please always indicate cut type (example: 2015/4)



Matrizenfrässtifte mit Stirnverzahnung Mould, tool and die making rotary burs with end cut

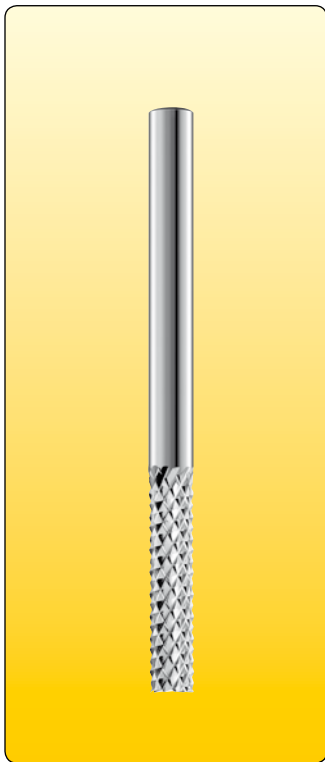

Auf Anfrage auch mit Cer-T Beschichtung lieferbar
Cer-T coating upon request

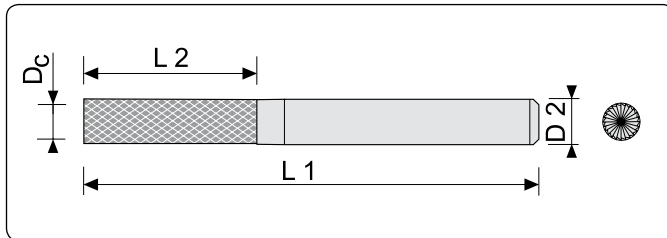

1.
03

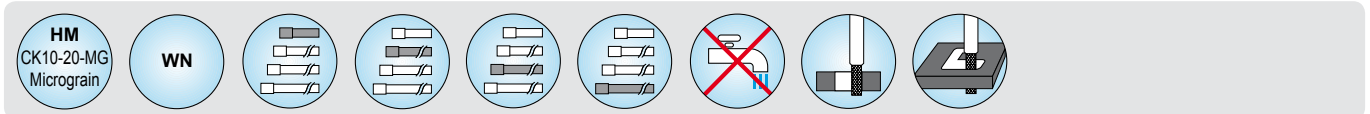

D _c	L2	L1	D2	Zahnung / Cut type						Zahnung 4 Cut type 4	Zahnung 6 Cut type 6
				1	2	3	4	5	6		
2,5	12	50	3,00	-	-	-	●	-	●	4025/4STx050	4025/6STx050
2,5	12	65	3,00	-	-	-	●	-	●	4025/4STx065	4025/6STx065
2,5	12	70	3,00	-	-	-	●	-	●	4025/4STx070	4025/6STx070
2,5	12	80	3,00	-	-	-	●	-	●	4025/4STx080	4025/6STx080
2,5	12	90	3,00	-	-	-	●	-	●	4025/4STx090	4025/6STx090
2,5	12	100	3,00	-	-	-	●	-	●	4025/4STx100	4025/6STx100
3	14	50	3,00	-	-	-	●	-	●	4033/4STx050	4033/6STx050
3	14	65	3,00	-	-	-	●	-	●	4033/4STx065	4033/6STx065
3	14	70	3,00	-	-	-	●	-	●	4033/4STx070	4033/6STx070
3	14	80	3,00	-	-	-	●	-	●	4033/4STx080	4033/6STx080
3	14	90	3,00	-	-	-	●	-	●	4033/4STx090	4033/6STx090
3	14	100	3,00	-	-	-	●	-	●	4033/4STx100	4033/6STx100

... Zahnung immer mit angeben (zum Beispiel: 2015/4)

... Please always indicate cut type (example: 2015/4)

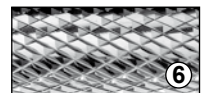
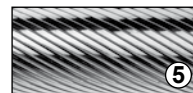
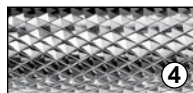
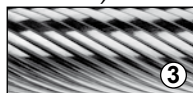
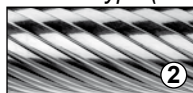

Glasnutenfräser - 90°
Grove cutters at 90°

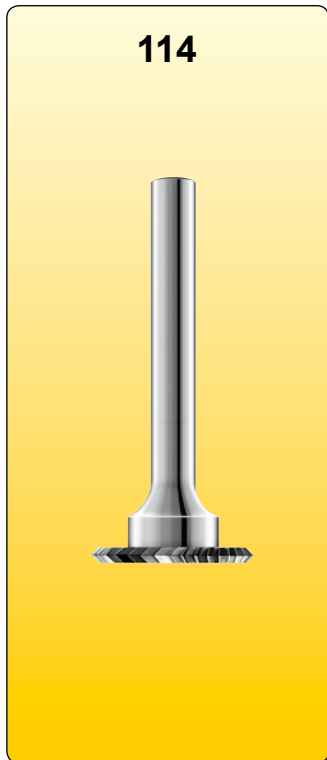

Auf Anfrage auch mit Cer-T Beschichtung lieferbar
Cer-T coating upon request

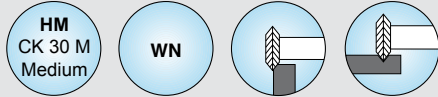
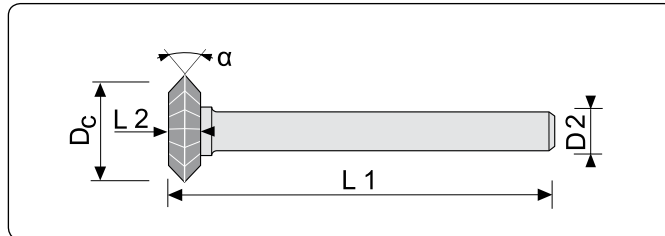

1.
04

D_c	L2	L1	D2	α	114-90°
10	1,5	47	6	90°	114.1015-90°
12	1,5	47	6	90°	114.1215-90°
16	1,5	47	6	90°	114.1615-90°
20	1,5	47	6	90°	114.2015-90°
10	2	47	6	90°	114.1020-90°
12	2	47	6	90°	114.1220-90°
16	2	47	6	90°	114.1620-90°
20	2	47	6	90°	114.2020-90°
10	2,5	47	6	90°	114.1025-90°
12	2,5	47	6	90°	114.1225-90°
16	2,5	47	6	90°	114.1625-90°
20	2,5	47	6	90°	114.2025-90°

Scheibenfräser abgerundet und zylindrisch
Disc cutters straight or with radius

Auf Anfrage auch mit Cer-T Beschichtung lieferbar
Cer-T coating upon request

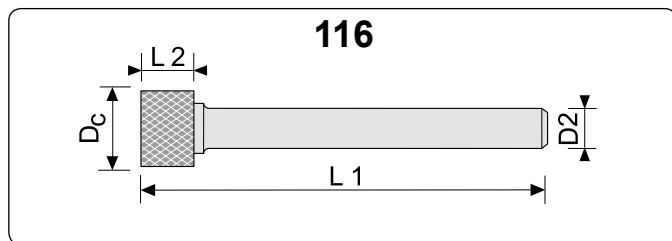
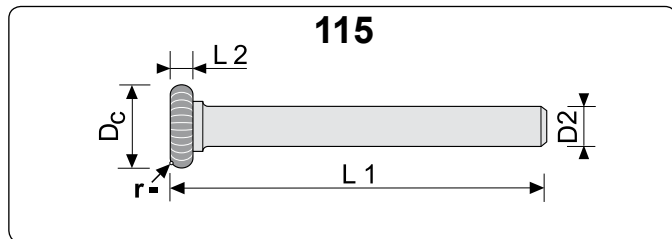
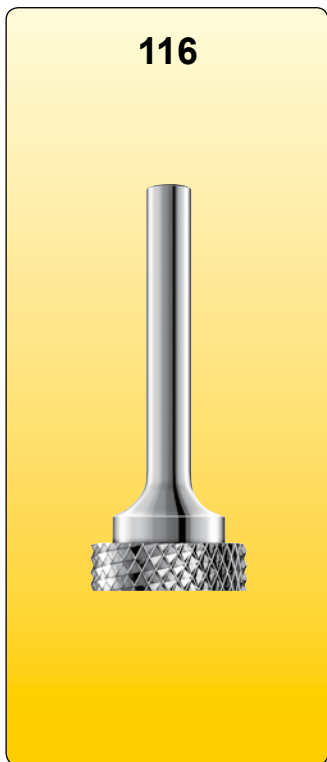
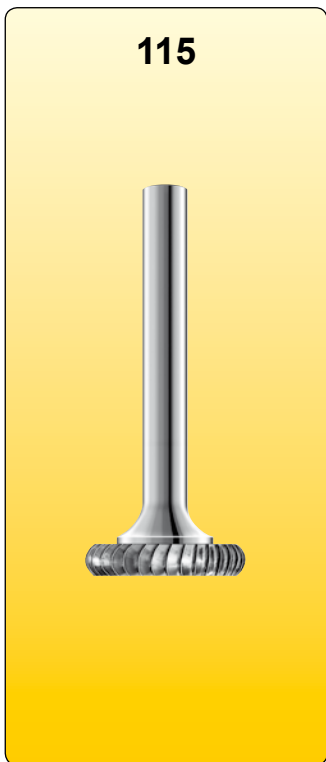

1.
04

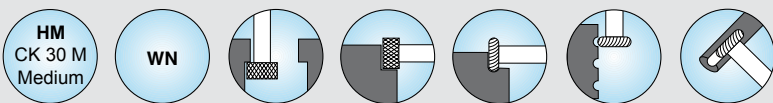

D _c	L ₂	L ₁	D ₂	r	115	116
10	2	47	6	20	1151006/3x2	1161006/4x2
10	3	48	6	20	1151006/3x3	1161006/4x3
10	4	49	6	20	1151006/3x4	1161006/4x4
10	6	51	6	20	1151006/3x6	1161006/4x6
12	2	47	6	24	1151206/3x2	1161206/4x2
12	3	48	6	24	1151206/3x3	1161206/4x3
12	4	49	6	24	1151206/3x4	1161206/4x4
12	6	51	6	24	1151206/3x6	1161206/4x4
16	2	47	6	30	1151606/3x2	1161606/4x2
16	3	48	6	30	1151606/3x3	1161606/4x3
16	4	49	6	30	1151606/3x4	1161606/4x4
16	6	51	6	30	1151606/3x6	1161606/4x6
16	8	53	6	30	1151606/3x8	1161606/4x8
20	2	47	6	35	1152006/3x2	1162006/4x2
20	4	49	6	35	1152006/3x4	1162006/4x4
20	6	51	6	35	1152006/3x6	1162006/4x6
20	8	53	6	35	1152006/3x8	1162006/4x8
20	10	55	6	35	1152006/3x10	1162006/4x10



VHM-Schaftfräser
End mills

Inhaltsverzeichnis

Index

Werkzeug Gruppe 2: Fräswerkzeuge	Tools Group 2: Milling cutters	Id. Nr. Code	Seite Page
Einführung	Introduction		75 ÷ 85

Werkzeug Gruppe 2.2: Kopierfräser und Hartfräser	Tools Group 2.2: Copying milling cutters and milling cutters for hard materials	Id. Nr. Code	Seite Page
Einführung	Introduction		88 ÷ 94
Radius Kopierfräser - Z=2 Drall 40° - ähnlich DIN 6527-L "ULTRA Ra" Speed Line mit feingeläppten Spannuten	Ball nose copy cutters - Z=2 Helix 40° - Similar to DIN 6527-L "ULTRA Ra" Speed Line with fine lapped chip flutes	102RC-40° 102RC-40°G	95
Radius Kopierfräser - Z=2 Drall 40° - WN extralang "ULTRA Ra" Speed Line mit feingeläppten Spannuten	Ball nose copy cutters - Z=2 Helix 40° - Internal standard extra long "ULTRA Ra" Speed Line with fine lapped chip flutes	102RCL-40° 102RCL-40°G	96
Torus Kopierfräser - Z=2 Drall 40° - ähnlich DIN 6527-L "ULTRA Ra" Speed Line mit feingeläppten Spannuten	Torus copy cutters - Z=2 Helix 40° - Similar to DIN 6527-L "ULTRA Ra" Speed Line with fine lapped chip flutes	102TC-40° 102TC-40°G	97
Torus Kopierfräser - Z=2 Drall 40° - WN extralang "ULTRA Ra" Speed Line mit feingeläppten Spannuten	Torus copy cutters - Z=2 Helix 40° - Internal standard extra long "ULTRA Ra" Speed Line with fine lapped chip flutes	102TCL-40° 102TCL-40°G	98
Torus Kopierfräser - Z=2 Drall 30° - WN	Torus copy cutters - Z=2 Helix 30° - Internal standard	72CT 72CTC	99
Radius Kopierfräser - Z=2 Drall 30° - WN	Ball nose copy cutters - Z=2 Helix 30° - Internal standard	72CR 72CRC	100
Torusfräser - Z=2 Drall 30° - WN - für gehärtete Stähle	Torus cutters - Z=2 Helix 30° - Internal standard - for hardened steels	62THR 62THRB	101
Radiusfräser - Z=2 Drall 30° - WN - für gehärtete Stähle	Ball nose cutters - Z=2 Helix 30° - Internal standard - for hardened steels	62RHR 62RHRB	102
Torusfräser - Z=4 Drall 30° - WN - für gehärtete Stähle	Torus cutters - Z=4 Helix 30° - Internal standard - for hardened steels	64THR 64THRB	103
Radiusfräser - Z=4 Drall 30° - WN - für gehärtete Stähle	Ball nose cutters - Z=4 Helix 30° - Internal standard - for hardened steels	64RHR 64RHRB	104
Mehrschneidenfräser - Drall 45° - WN - für gehärtete Stähle	Multiflutes cutters - Helix 45° - Internal standard - for hardened steels	66HR 66HRB	105
Torus Mehrschneidenfräser - Drall 45° - WN - für gehärtete Stähle	Torus multiflutes cutters - Helix 45° - Internal standard - for hardened steels	66THR 66THRB	106

Werkzeug Gruppe 2.3: Fräser für Graphitbearbeitung	Tools Group 2.3: Milling cutters for graphite	Id. Nr. Code	Seite Page
Einführung	Introduction		109 ÷ 110
Einsatzdaten: f (mm) - Kreuzverzahnt - mit Cer-D Beschichtung Schaft und Radiusfräser - mit spezial Kreuzverzahnung (F/M) - mit Feinverzahnung und Spanteiler (66GF-D)	Cutting data: f (mm) - Cross cut - with Cer-D coating End mills and ball nose cutters - with special cross cut (F/M) - with fine cut and chip breaker (66GF-D)	GF GM	111

Torus Graphitfräser - Z=2 Drall 30° - WN	<i>Torus cutters for graphite - Z=2 Helix 30° - Internal standard</i>	72GT 72GTD	112
Radius Graphitfräser - Z=2 Drall 30° - WN	<i>Ball nose cutters for graphite - Z=2 Helix 30° - Internal standard</i>	72GR 72GRD	113
Radius Graphitfräser - Z=3 Drall 30° Ungleiche Schneidenteilung - WN	<i>Radius cutters for graphite - Z=3 Helix 30° univen indexing - Internal Standard</i>	73GRI 73GRID	114
Torus Graphitfräser - Z=3 Drall 30° Ungleiche Schneidenteilung - WN	<i>Torus cutters for graphite - Z=3 Helix 30° univen indexing - Internal Standard</i>	73GTI 73GTID	115
Graphit Nutenfräser - spezial Kreuzverzahnung - WN	<i>Slot milling cutters for graphite - special cross cut - Internal Standard</i>	108GFD 108GMD	116
Graphit Bohrfräser - spezial Kreuzverzahnung - WN	<i>Drill milling cutters for graphite - special cross cut - Internal Standard</i>	109GFD 109GMD	117
Graphit - Radiusfräser - kreuzverzahnt - WN	<i>Ball nose cutters for graphite - cross cut - Internal Standard</i>	106RGFD 106RGMD	118
Graphit - Schafffräser - engverzahnt - mit Spanteiler - WN	<i>End mills for graphite - fine cut with chip breaker - Internal Standard</i>	66GF 66GFD	119
Graphit Radiusfräser - engverzahnt mit Spanteiler - WN	<i>Ball nose end mills for graphite - fine cut with chip breaker - Internal Standard</i>	66RGF 66RGFD	120

Werkzeug Gruppe 2.4: Fräswerkzeuge für Kunststoff	Tools Group 2.4: End mills for composite materials	Id. Nr. Code	Seite Page
Einführung	<i>Introduction</i>		122 ÷ 126
Rechts- und Linksdrall - Z=2+2 "Butterfly" - WN	<i>Right and left helix - Z=2+2 "Butterfly" - Internal standard</i>	102PH 102PHE	128
Bohrfräser "Dummy" mit gegenläufiger Spitzverzahnung - WN	<i>Drill milling cutters "Dummy" with counter- wise point cut - Internal standard</i>	119P 119PE	129
Kunststoff-Fräser gerade genutet - große Spannuten - mit Spanteiler - WN	<i>End mills for composite materials - straight flute - with chip breaker - Internal standard</i>	65SU 65SUE	130
Kunststoff Fräser - 10° Rechtsdrall - grobe gegenläufige Spanteiler - WN	<i>End mills for composite materials - 10° right helix - large counterwise chip breaker - Internal standard</i>	66SU 66SUE	131
CFK Fräser - kreuzverzahnt - mit Stirnverzahnung Z=2 - WN	<i>End mills for Carbonfibre - with two frontal teeth Z=2 - Internal standard</i>	68SU 68SUD	132
Kunststoff Fräser - kreuzverzahnt - ohne Stirnverzahnung - WN	<i>End mills for composite materials - cross cut - without end cut - Internal standard</i>	106F - 106M 106G	133
Kunststoff Fräser - kreuzverzahnt - mit Stirnverzahnung - WN	<i>End mills for composite materials - cross cut - with end cut - Internal standard</i>	107F - 107M 107G	134
Bohrnutenfräser - kreuzverzahnt - WN	<i>Drill slot milling cutters - cross cut - Internal standard</i>	108F - 108M 108G	135
Bohrfräser - kreuzverzahnt - WN	<i>Drill milling cutters - cross cut - Internal standard</i>	109F - 109M 109G	136
Radiusfräser - kreuzverzahnt - WN	<i>Ball nose end mills - cross cut - Internal standard</i>	106RF 106RM	137
Schafffräser Z=2 Drall 14° - ähnlich DIN 6527-L	<i>End mills Z=2 Helix 14° - Similar to DIN 6527-L</i>	102S 102SE	138
"ULTRA Ra" Speed Line mit feingeläppten Spannuten	<i>"ULTRA Ra" Speed Line with fine lapped chip flutes</i>		
Honeycomb Fräser - grobe gegenläufige Spanteiler - WN	<i>End mills for honeycomb - large counterwise chip breaker - Internal standard</i>	77SU 77SUE	139

Werkzeug Gruppe 2.5: Schafffräser - Typ "W"	Tools Group 2.5: "W" design end mills	Id. Nr. Code	Seite Page
Einführung	<i>Introduction</i>		142 ÷ 147
Schafffräser - Z=1 gerade genutet - WN "ULTRA Ra" Speed Line mit feingeläppten Spannuten	<i>End mills - Z=1 straight flute - Internal standard "ULTRA Ra" Speed Line with fine lapped chip flutes</i>	110TD 110TDG	148
Radius fräser - Z=1 gerade genutet - WN "ULTRA Ra" Speed Line mit feingeläppten Spannuten	<i>Ball nose cutter - Z=1 straight flute - Internal standard "ULTRA Ra" Speed Line with fine lapped chip flutes</i>	110TDR 110TDRG	149
Einschneidenfräser Rechtsdrall und Rechtsschneidend für Aluminium "ULTRA Ra" Speed Line mit feingeläppten Spannuten	<i>Single Flute routers Right hand Spiral - Right hand cut for Aluminium "ULTRA Ra" Speed Line with fine lapped chip flutes</i>	110A 110AG	150
Einschneidenfräser Linksdrall und Rechtsschneidend für Aluminium "ULTRA Ra" Speed Line mit feingeläppten Spannuten	<i>Single Flute routers Left hand Spiral - Right hand cut for Aluminium "ULTRA Ra" Speed Line with fine lapped chip flutes</i>	111A 111AG	151
Einschneidenfräser Rechtsdrall und Rechtsschneidend "ULTRA Ra" Speed Line mit feingeläppten Spannuten	<i>Single Flute routers Right hand Spiral - Right hand cut "ULTRA Ra" Speed Line with fine lapped chip flutes</i>	110 110G	152
Einschneidenfräser Linksdrall und Rechtsschneidend "ULTRA Ra" Speed Line mit feingeläppten Spannuten	<i>Single Flute routers Left hand Spiral - Right hand cut "ULTRA Ra" Speed Line with fine lapped chip flutes</i>	111 111G	154
Radius Einschneidenfräser Rechtsdrall und Rechtsschneidend "ULTRA Ra" Speed Line mit feingeläppten Spannuten	<i>Radius Single Flute routers Right hand Spiral - Right hand cut "ULTRA Ra" Speed Line with fine lapped chip flutes</i>	110R 110RG	156
Schafffräser - Z=2 gerade genutet - WN "ULTRA Ra" Speed Line mit feingeläppten Spannuten	<i>End mills - Z=2 straight flute - Internal standard "ULTRA Ra" Speed Line with fine lapped chip flutes</i>	100 100G	157
Schafffräser - Z=2 Drall 30° - WN "ULTRA Ra" Speed Line mit feingeläppten Spannuten - doppeltem Spanwinkel - konische Seele	<i>End mills - Z=2 Helix 30° - Internal standard "ULTRA Ra" Speed Line with fine lapped chip flutes-with double rake angle - conical core</i>	102A 102AG	158
Schafffräser - Z=2 Drall 30° - WN "ULTRA Ra" Speed Line mit feingeläppten Spannuten	<i>End mills - Z=2 Helix 30° - Internal standard "ULTRA Ra" Speed Line with fine lapped chip flutes</i>	102 102G	159
Schafffräser - Z=2 Linksdrall-rechtsschneidend - WN "ULTRA Ra" Speed Line mit feingeläppten Spannuten	<i>End mills - Z=2 Left hand spiral - Right hand cut - Internal standard "ULTRA Ra" Speed Line with fine lapped chip flutes</i>	104 104G	160
Schafffräser - Z=2 Drall 45° - WN "ULTRA Ra" Speed Line mit feingeläppten Spannuten	<i>End mills - Z=2 Helix 45° - Internal standard "ULTRA Ra" Speed Line with fine lapped chip flutes</i>	102-45° 102-45°G	161
Schafffräser - Z=3 gerade genutet - WN "ULTRA Ra" Speed Line mit feingeläppten Spannuten	<i>End mills - Z=3 straight flute - Internal standard "ULTRA Ra" Speed Line with fine lapped chip flutes</i>	101 101G	162
Schafffräser - Drall 45° - ähnlich DIN 6527-L - Für Plexiglass Ultra-läppen "PIRAÑA" ungleiche Schneidenteilung - feingeläppte Spannuten	<i>End mills - Helix 45° - Similar to DIN 6527-L - for super-finishing of Plexiglass "PIRAÑA" uneven division of cutting edges - fine lapped chip flutes</i>	103S 103SE	163
Schafffräser - Z=3 Drall 30° - Linksdrall-rechtsschneidend - WN "ULTRA Ra" Speed Line mit feingeläppten Spannuten	<i>End mills - Z=3 Helix 30° - Left hand spiral - Right hand cut - Internal standard "ULTRA Ra" Speed Line with fine lapped chip flutes</i>	105 105G	164
Schafffräser - Z=3 Drall 30° - ähnlich DIN 6527-L "PIRAÑA" ungleiche Schneidenteilung - feingeläppte Spannuten	<i>End mills - Z=3 Helix 30° - Similar to DIN 6527-L "PIRAÑA" uneven division of cutting edges - fine lapped chip flutes</i>	103I 103IG	165

Torusfräser - Z=3 Drall 30° - ähnlich DIN 6527-L "PIRAÑA" ungleiche Schneidenteilung - feingeläppte Spannuten	<i>Torus cutters - Z=3 Helix 30° - Similar to DIN 6527-L "PIRAÑA"uneven division of cutting edges - fine lapped chip flutes</i>	103TI 103TIG	166
Schafffräser - Z=3 Drall 45° - ähnlich DIN 6527-L "PIRAÑA" ungleiche Schneidenteilung - feingeläppte Spannuten	<i>End mills - Z=3 Helix 45° - Similar to DIN 6527-L "PIRAÑA"uneven division of cutting edges - fine lapped chip flutes</i>	103I-45° 103I-45°G	167
Radiusfräser - Z=3 Drall 30° - ähnlich DIN 6527-L "PIRAÑA" ungleiche Schneidenteilung - feingeläppte Spannuten	<i>Ball nose cutters - Z=3 Helix 30° - Similar to DIN 6527-L "PIRAÑA"uneven division of cutting edges - fine lapped chip flutes</i>	103RI 103RIG	168
Z=1 mit Rechtsdrall und Spanbrechernuten - WN "ULTRA Ra" Speed Line mit feingeläpften Spannuten	<i>Z=1 with right helix and chip breaker - Internal standard "ULTRA Ra" Speed Line with fine lapped chip flutes</i>	110SP 110SPG	169

Werkzeug Gruppe 2.6: Schruppfräser	Tools Group 2.6: Roughing end mills	Id. Nr. Code	Seite Page
Einführung	<i>Introduction</i>		172 ÷ 174
Hochleistungs Schruppfräser - Drall 45° - ähnlich DIN 6527-L	<i>High performance roughing end mills Helix 45° - Similar to DIN 6527-L</i>	64SS 64SSC 64SSW 64SSWC	175
Schruppfräser - Z=3 Drall 30° - ähnlich DIN 6527-L	<i>Roughing end mills - Z=3 Helix 30° - Similar to DIN 6527-L</i>	63SP 63SPC 63SPW 63SPWC	176
Schruppfräser - Z=3 Drall 45° - ähnlich DIN 6527-L	<i>Roughing end mills - Z=3 Helix 45° - Similar to DIN 6527-L</i>	63SP-45° 63SP-45°C 63SPW-45° 63SPW-45°C	177
Schruppfräser - Z=4 Drall 30° - DIN 6527-L	<i>Roughing end mills - Z=4 Helix 30° - DIN 6527-L</i>	64SP 64SPC 64SPW 64SPWC	178

Werkzeug Gruppe 2.7: Schafffräser - mit 2 Schneiden	Tools Group 2.7: 2 flutes end mills	Id. Nr. Code	Seite Page
Einführung	<i>Introduction</i>		180 ÷ 182
Schafffräse - Z=2 gerade genutet - WN "ULTRA Ra" Speed Line mit feingeläpften Spannuten	<i>End mills Z=2 straight flute - Internal standard "ULTRA Ra" Speed Line with fine lapped chip flutes</i>	62TD 62TDA	183
Radiusfräser - Z=2 gerade genutet - WN "ULTRA Ra" Speed Line mit feingeläpften Spannuten	<i>Radius end mills - Z=2 straight flute - Internal standard "ULTRA Ra" Speed Line with fine lapped chip flutes</i>	62TDR 62TDRA	184
Schafffräser - Z=2 Drall 30° - ähnlich DIN 6527-L	<i>End mills - Z=2 Helix 30° - Similar to DIN 6527-L</i>	62 62A 62W 62WA	185

Schaftfräser - Z=2 Drall 45° - DIN 6527-L	<i>End Mills - Z=2 Helix 45° - DIN 6527-L</i>	62-45° 62-45°A 62W-45° 62W-45°A	186
Schaftfräser - Z=2 Drall 30° - WN überlang	<i>End Mills - Z=2 Helix 30° - Internal standard long</i>	62L 62LA	187
Schaftfräser - Z=2 Drall 30° - WN extralang	<i>End mills - Z=2 Helix 30° - Internal standard extra long</i>	62XL 62XLA	188
Radius Schaftfräser - Z=2 Drall 30° - ähnlich DIN 6527-L	<i>Ball nose end mills - Z=2 Helix 30° - Similar to DIN 6527-L</i>	62R 62RA 62RW 62RWA	189
Radius Schaftfräser - Z=2 Drall 45° - DIN 6527-L	<i>Ball nose end mills - Z=2 Helix 45° - DIN 6527-L</i>	62R-45° 62R-45°A 62RW-45° 62RW-45°A	190
Radius Schaftfräser - Z=2 Drall 30° - WN überlang	<i>Ball nose end mills - Z=2 Helix 30° - Internal standard long</i>	62RL 62RLA	191
Radius Schaftfräser - Z=2 Drall 30° - WN extralang	<i>Ball nose end mills - Z=2 Helix 30° - Internal standard extra long</i>	62RXL 62RXLA	192
Werkzeug Gruppe 2.8: Schaftfräser - mit 3 Schneiden	Tools Group 2.8: 3 flutes end mills	Id. Nr. Code	Seite Page
Schaftfräser - Z=3 "PIRAÑA"-SQ ungleiche Schneidenteilung und - Spiralwinkel - DIN 6527-L	<i>End Mills - Z=3 "PIRAÑA"-SQ uneven divi- sion of cutting edges and helix angle - DIN 6527-L</i>	63ISQ 63ISQC	194
Schaftfräser - Z=3 "PIRAÑA"-SQ ungleiche Schneidenteilung und -Spiralwinkel - DIN 6527-L	<i>End Mills - Z=3 "PIRAÑA"-SQ uneven divi- sion of cutting edges and helix angle - DIN 6527-L</i>	63TISQ 63TISQC	195
Schaftfräser - Z=3 Drall 30° - WN	<i>End mills - Z=3 Helix 30° - Internal standard</i>	63 63A 63W 63WA	196
Schaftfräser - Z=3 Drall 45° - DIN 6527-L	<i>End mills - Z=3 Helix 45° - DIN 6527-L</i>	63-45° 63-45°A 63W-45° 63W-45°A	197
Schaftfräser - Z=3 Drall 30° - WN überlang	<i>End mills - Z=3 Helix 30° - Internal standard long</i>	63L 63LA	198
Schaftfräser - Z=3 Drall 30° - WN extralang	<i>End mills - Z=3 Helix 30° - Internal standard extra long</i>	63XL 63XLA	199
Radiusfräser - Z=3 Drall 30° - WN	<i>Ball nose end mills - Z=3 Helix 30° - Internal standard</i>	63R 63RA 63RW 63RWA	200
Radiusfräser - Z=3 Drall 30° - WN überlang	<i>Ball nose end mills - Z=3 Helix 30° - Internal standard long</i>	63RL 63RLA	201
Radius Schaftfräser - Z=3 Drall 30° - WN extralang	<i>Ball nose end mills - Z=3 Helix 30° - Internal standard extra long</i>	63RXL 63RXLA	202

Konische Schafffräser - Z=3 - konstante Spiralsteigung - WN	<i>Taper end mills - Z=3 - constant spiral angle - Internal standard</i>	63K 63KA	203
Konische Radiusfräser - Z=3 - konstante Spiralsteigung - WN	<i>Taper ball nose end mills - Z=3 - constant spiral angle - Internal standard</i>	63KR 63KRA	204

Werkzeug Gruppe 2.9: Schafffräser - mit 4 Schneiden	Tools Group 2.9: 4 flutes end mills	Id. Nr. Code	Seite Page
Schafffräser - Z=4 Drall 30° - WN	<i>End mills - Z=4 Helix 30° - Internal standard</i>	64 64A 64W 64WA	207
Schafffräser - Z=4 Drall 30° - WN überlang	<i>End mills - Z=4 Helix 30° - Internal standard long</i>	64L 64LA	208
Schafffräser - Z=4 Drall 30° - WN extralang	<i>End mills - Z=4 Helix 30° - Internal standard extra long</i>	64XL 64XLA	209
Radius Schafffräser - Z=4 Drall 30° - WN	<i>Ball nose cutters - Z=4 Helix 30° - Internal standard</i>	64R 64RA 64RW 64RWA	210
Radius Schafffräser - Z=4 Drall 30° - WN überlang	<i>Ball nose cutters - Z=4 Helix 30° - Internal standard long</i>	64RL 64RLA	212
Radius Schafffräser - Z=4 Drall 30° - WN extralang	<i>Ball nose cutters - Z=4 Helix 30° - Internal standard extra long</i>	64RXL 64RXLA	213

Werkzeug Gruppe 2.10: Mehrschneiden-Schlichtfräser	Tools Group 2.10: Multi-flute finishing end mills	Id. Nr. Code	Seite Page
Schafffräser - Z=6 Drall 25° - Typ H - WN	<i>End mills - Z=6 Helix 25° - "H" design - Internal standard</i>	66 66A	216
Mehrschneiden-Schlichtfräser - ungerade Schneidenzahl - WN	Multi-flute finishing end mills - uneven number of flutes - Internal standard	66Z 66ZA	217
Schafffräser - engverzahnt - mit Spanteiler - WN	End mills - Fine cut with chipbreaker - Internal standard	66M 66MA	218
Radius Schafffräser - engverzahnt mit Spanteiler - WN	Ball nose end mills - Fine cut with chipbreaker - Internal standard	66MR 66MRA	219

Werkzeug Gruppe 2.11: Gravierstichel	Tools Group 2.11: Engraving tools	Id. Nr. Code	Seite Page
Rundstäbe	<i>Round blanks</i>	90	222
Gravierstichel einseitig vorprofiliert	<i>Engraving tool preshaped on one side</i>	91	223
Gravierstichel - einseitig profiliert 90° - 60°	<i>Engraving tool 90° - 60° shaped on one side</i>	94-90° 94-60°	224
Vierkantstäbe	<i>Square blanks</i>	200	225
Vierkantstäbe flach	<i>Rectangular blanks</i>	200	226

Um der ständigen Evolution des Marktes gerecht zu werden, hat Cerin eine umfassende und fortschrittliche Palette von Vollhartmetallfräsern auf den Markt gebracht. Neben der bekannten traditionellen Serie wurden Fräser entsprechend den neuesten DIN-Normen eingeführt, wie auch eine differenzierte Palette, die von langen, und überlangen Fräsern bis zu Schruppfräsern und konischen Fräsern geht. Ein besonderer, "PIRAÑA" genannter Fräser ist bei den Kunden auf Anklang gestoßen, weil er vibrationsfrei arbeitet und eine hohe Oberflächengüte des Werkstücks garantiert.

Cerin have always been sensitive to market trends and now offer a wide and technologically advanced range of solid carbide end mills. In addition to the well-known traditional products, Cerin supplies cutters which comply with the most recent DIN norms as well as a diversified range of long and extra-long, roughing and conical cutters. A special cutter, called «PIRAÑA», is very successful and appreciated thanks to its vibrationless machining and the excellent finish of the workpiece.

GLEICHLAUFFRÄSEN

Die Drehrichtung des Fräsers und der Vorschub des Werkstücks gehen in die gleiche Richtung.

Beim Eintauchen des Fräsers wird das Material mit der größten Spandicke abgetragen und beim Verlassen des Materials ist die Spanstärke am geringsten.

DOWN MILLING

Cutter rotation and work feed have the same direction.

The cutter machines the material at the maximum chip thickness and leaves it at the minimum.

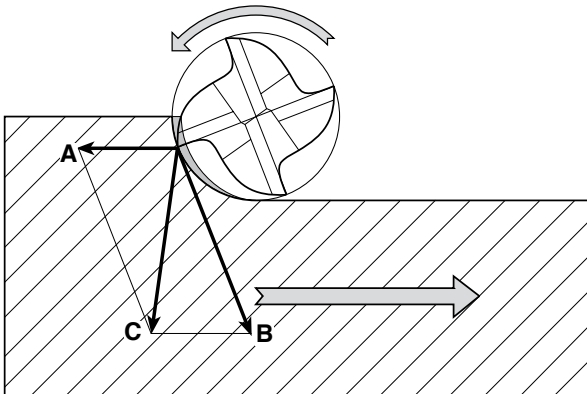

Die wichtigsten Merkmale sind die folgenden:

- Verringerung der Vibrationen
- Hohe Oberflächengüte
- Längere Haltbarkeit der Schneiden
- Möglichkeit, eine größere Schnittgeschwindigkeit zu verwenden.

Main features:

- less vibrations
- good surface quality
- longer life of cutting edges
- higher cutting speed.

GEGENLAUFFRÄSEN

Die Drehrichtung des Fräsers und der Vorschub des Werkstücks gehen in entgegengesetzter Richtung.

Beim Eintauchen des Fräsers wird das Material mit der geringsten Spandicke abgetragen und beim Verlassen des Materials ist die Spanstärke am größten.

UP MILLING

Cutter rotation and work feed have opposite directions.

The material is cut at the minimum thickness and left at the maximum.

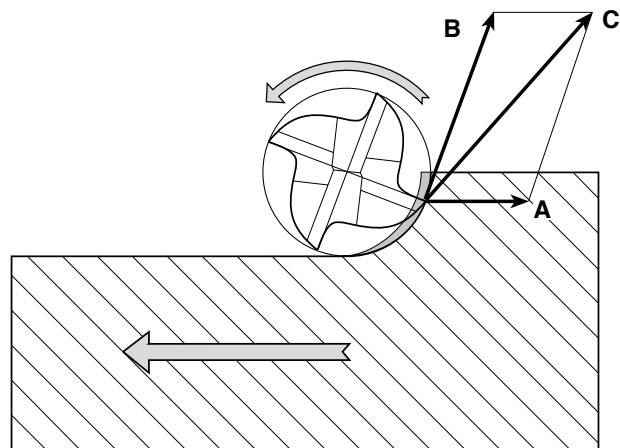

Die wichtigsten Merkmale sind die folgenden:

- Stärkere Vibrationen infolge der Zunahme der Schnittkraft
- Geringere Haltbarkeit des Fräsers infolge der stärkeren Reibung der Schneiden im ersten Arbeitsabschnitt
- Die vertikale Komponente der Schnittkraft führt zum Abheben des Werkstücks vom Tisch.

Main features:

- more vibrations due to increased shear stress
- shorter life of cutter due to higher wear of cutting edges in the first working length
- the vertical shearing stress component tends to detach the work from the table.

Anwendungen für Fräswerkzeuge Applications for milling cutters

Anwendungsbeispiele / Application examples

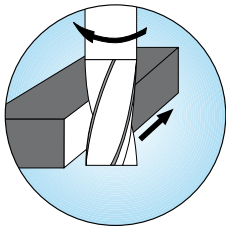

Besäumen - Konturfräsen
große Schnitttiefe a_p
geringe Bearbeitungsbreite a_e

Contour milling
Axial depth of cut a_p
Radial depth of cut a_e

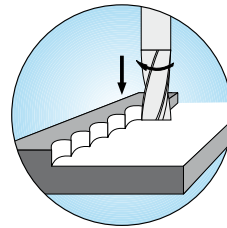

Tauchfräsen
Durch Bohrbearbeitung in Z tiefe Nuten vorbereiten

Plunge milling
by using drilling in Z-axis to open up a deep slot

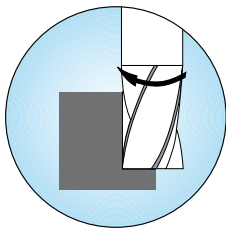

Eckfräsen
große Schnitttiefe a_p
geringe Bearbeitungsbreite a_e

Side milling
Axial depth of cut a_p
Radial depth of cut a_e

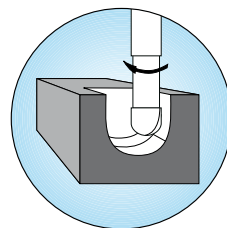

Kopierfräsen
geringe Spanquerschnitte mit großen Radiuswerkzeugen

Copy milling
small chip sections with large radius cutters

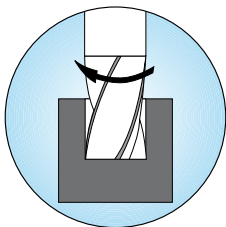

Nutenfräsen ins Volle
Bearbeitungsbreite $D_c \times 1$
Schnitttiefe $a_p = D_c \times 1$

Slot milling
working width $D_c \times 1$
Axial depth of cut $a_p = D_c \times 1$

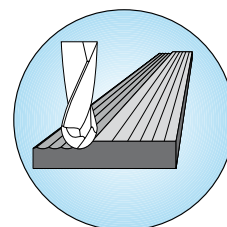

Kopierfräsen
geringe Spanquerschnitte mit großen Radiuswerkzeugen

Copy milling
small chip sections with large radius cutters

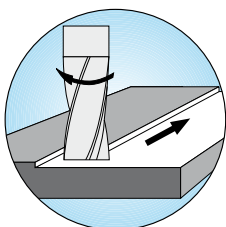

Stirn- und Planfräsen
geringe Schnitttiefe a_p
Bearbeitungsbreite bis $D_c \times 1$

Face milling
Axial depth of cut a_p
working width up to $D_c \times 1$

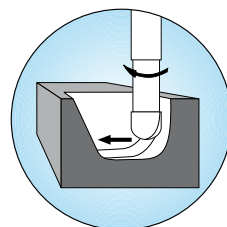

Bohr-Ziehtauchen
Konturbearbeitung im 3D Verfahren

Push-pull plunging
Copying movements in 3D machining

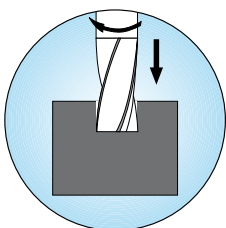

Bohren
Bearbeitung nur in Z

Drilling
feed only in Z-axis

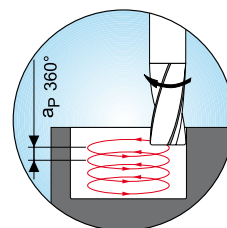

Innen Zirkularfräsen
Bohrbearbeitung mit zirkularer Zustellung in Z

Internal helical interpolation ramping
drilling operation with circular movement in Z-axis

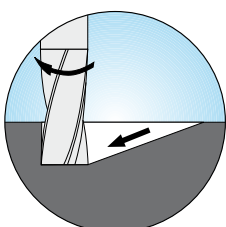

Schräg eintauchen
Eintauchen Z in einem Winkel wirtschaftlicher als Bohren

Ramping
angular ramping in Z-axis is more economical than drilling

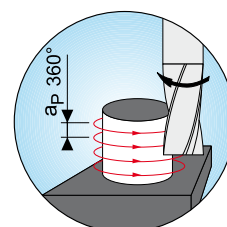

Umfang Zirkularfräsen
Außenbearbeitung mit zirkularer Zustellung in Z

External helical interpolation ramping
circumference operation with circular movement in Z-axis

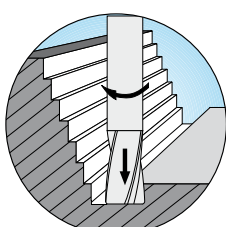

Zeilenfräsen (Vorfräsen)
Bohren in Z - dann Linearbearbeitung

Z - leveling
Drilling in Z-axis then linear x-y movement

02

Kurzbezeichnungen der technischen Begriffe
Brief description of technical terms

Benennung / Denomination	Einheit / Unit	Kennzeichnung / Symbol	
		DIN 6580/84	Alt - old
Arbeitsdurchmesser <i>Working diameter</i>	mm	D _w	d _{1eff}
Drehzahl <i>Revolution per min.</i>	min ⁻¹	n	n
Fräs- und Bohrhub <i>Milling (drilling) length</i>	mm	l _f	L
Leistung <i>Output</i>	KW	P _c	P _e
Nutzdauer <i>Working life</i>	min	T	
Schaftdurchmesser <i>Shank diameter</i>	mm	dm _m	d ₁
Schnittbreite <i>Radial depth of cut</i>	mm	a _e	e
Schneidendurchmesser <i>Milling cutter diameter</i>	mm	D _c	D _s
Schnittgeschwindigkeit <i>Cutting speed</i>	m/min	V _c	V
Schnittkraft <i>Cutting force</i>	N	F _c	F _s
Schnitttiefe <i>Axial depth of cut</i>	mm	a _p	a
Spanleistung <i>Resulting cutting force</i>	N	F	
Spanstärke <i>Chip thickness</i>	mm	h	h
Spanstärke (mittlere) <i>Average chip thickness</i>	mm	h _m	h _m
Vorschub pro Umdrehung <i>Feed per revolution</i>	mm	f	s
Vorschub pro Zahn <i>Feed per tooth</i>	mm	f _z	S _z
Vorschubgeschwindigkeit <i>Feed per minute</i>	mm/min	V _f	U
Zähnezahl <i>Number of teeth</i>		Z _n	Z
Rautiefe <i>Roughness</i>	µm	R _{th}	H

02

Berechnungsformeln Formulae of calculation

02

Schaft- Radius- und Torusfräser End mills - Torus cutters - Ball nose cutters		Kopier- Zeilenfräsen Trace milling	
Drehzahl Revolution per minute	$n = \frac{V_c \times 1000}{D_c \times 3,14}$		
Schnittgeschwindigkeit Cutting speed	$V_c = \frac{D_c \times 3,14 \times n}{1000}$		
Vorschub/Zahn Feed per tooth	$f_z = \frac{V_f}{Z_n \times n}$	R_{th} Rautiefe / Surface roughness	b_r Zeilensprung / Line offset
Vorschub/Umdrehung Feed for revolution	$f = f_z \times Z_n$	D_w Arbeitsdurchmesser / Working diameter	
Vorschubgeschwindigkeit Feed per minute	$V_f = f_z \times Z_n \times n$		
Mittenspanndicke Average chip thickness	$h_m = f_z \times \sqrt{\frac{a_e}{D_c}}$		
		Rautiefe Roughness	$R_{th} = \frac{D_c}{2} \sqrt{\frac{D_c^2 - b_r^2}{4}}$
		Zeilensprung Line offset	$b_r = 2 \sqrt{R_{th} (D_c - R_{th})}$
		Arbeitsdurchmesser Working diameter	$D_w = 2 \sqrt{a_p (D_c - a_p)}$

Berechnungsformeln Formulae of calculation

Zirkularfräsen Bohrfräsen - Vorschubgeschwindigkeit Fräsermittelpunktsbahn V_{FM} (mm/min.) Circular milling - Drill milling - Feed based on movement of the cutter axis V_{FM} (mm/min.)			
		Innenkontur Internal profile	$V_{FM} = \frac{V_f \times (D - D_c)}{D}$
		Außenkontur External profile	$V_{FM} = \frac{V_f \times (D + D_c)}{D}$

PROBLEM PROBLEM		ABHILFE REMEDY	ERHÖHEN INCREASE
Schneidenausbruch <i>Cutting edge spalling</i>	Vorschub pro Zahn <i>Tooth feed</i>	Schnittgeschwindigkeit - Zähigkeit des Hartmetalls - Schneidphase - Stabilität der Maschine <i>Cutting speed - Carbide toughness - Cutting edge phase - Machine stability</i>	
Schneidenverschleiß <i>Cutting edge wear</i>	Schnittgeschwindigkeit <i>Cutting speed</i>	Vorschub pro Zahn - Verschleißfestigkeit des Hartmetalls - Schneidphase <i>Tooth feed Carbide wear resistance Cutting edge phase</i>	
Auskolkung <i>Cratering</i>	Schnittgeschwindigkeit Vorschub pro Zahn <i>Cutting speed Tooth feed</i>	Verschleißfestigkeit des Hartmetalls Kühlmitteldruck <i>Carbide wear resistance Coolant pressure</i>	
Aufbauschneide <i>Deposit on cutting edge</i>	Schnitttiefe <i>Cutting depth</i>	Schnittgeschwindigkeit Vorschub pro Zahn Kühlmitteldruck <i>Cutting speed Tooth feed Coolant pressure</i>	
Schlechte Oberflächengüte des Werkstücks <i>Bad workpiece surface</i>	Vorschub pro Zahn Schneidphase Schnitttiefe <i>Tooth feed Cutting edge phase Cutting depth</i>	Schnittgeschwindigkeit - Stabilität der Maschine - Drallwinkel - Konzentrität des Fräsers-Zahl der Schneiden <i>Cutting speed - Machine stability - Helix angle - Mill concentricity - Number of flute</i>	
Vibrationen <i>Vibrations</i>	Schnitttiefe Schnittgeschwindigkeit <i>Cutting depth Cutting speed</i>	Stabilität der Maschine Stabilität des Werkstücks Kühlmittelviskosität <i>Machine stability Workpiece stability Coolant density</i>	
Werkstückausbruch <i>Spalling workpiece</i>	Vorschub pro Zahn Schneidphase Schnitttiefe <i>Tooth feed Cutting edge phase Cutting depth</i>		
Überlastung der Maschine <i>Overload machine</i>	Schnittgeschwindigkeit Vorschub pro Zahn Schnitttiefe <i>Cutting speed Tooth feed Cutting depth</i>		
			VERRINGERN DECREASE

Schnittgeschwindigkeiten V_c (m/min) - Drehzahlen n (min⁻¹)
Cutting speeds V_c (m/min) - Revolution per minute n (min⁻¹)

Berechnungsformeln: Schnittgeschwindigkeit V_c (m/min) - Drehzahl n (min⁻¹)
Calculation formula: Cutting speed V_c (m/min) - Revolution per minute n (min⁻¹)

$$V_c \text{ (m/min)} = \frac{D_c \text{ (mm)} \times 3,14 \times n \text{ (min}^{-1}\text{)}}{1000}$$

$$n \text{ (min}^{-1}\text{)} = \frac{V_c \text{ (m/min)} \times 1000}{D_c \text{ (mm)} \times 3,14}$$

V_c (m/min)	D_c (mm)								
	1,00	1,5	2,00	2,50	3,00	4,00	5,00	6,00	8,00
	Drehzahl n (min⁻¹) / Revolution per minute n (min⁻¹)								
20	6369	4245	3185	2548	2123	1592	1274	1062	796
25	7962	5307	3981	3185	2654	1990	1592	1327	995
30	9554	6368	4777	3822	3185	2389	1911	1592	1194
40	12739	8491	6369	5096	4246	3185	2548	2123	1592
50	15924	10613	7962	6369	5308	3981	3185	2654	1990
60	19108	12736	9554	7643	6369	4777	3822	3185	2389
80	25478	16982	12739	10191	8493	6369	5096	4246	3185
100	31847	21227	15924	12739	10616	7962	6369	5308	3981
125	39809	26534	19904	15924	13270	9952	7962	6635	4976
150	47771	31840	23885	19108	15924	11943	9554	7962	5971
175	55732	37147	27866	22293	18577	13933	11146	9289	6967
200	63694	42454	31847	25478	21231	15924	12739	10616	7962
250	79618	53067	39809	31847	26539	19904	15924	13270	9952
300	95541	63681	47771	38217	31847	23885	19108	15924	11943
400	127389	84908	63694	50955	42463	31847	25478	21231	15924
450	143312	95521	71656	57325	47771	35828	28662	23885	17914
500	159236	106135	79618	63694	53079	39809	31847	26539	19904
600		127361	95541	76433	63694	47771	38217	31847	23885
800			127389	101911	84926	63694	50955	42463	31847
1000				127389	106157	79618	63694	53079	39809

V_c (m/min)	D_c (mm)								
	10,00	12,00	14,00	15,00	16,00	18,00	20,00	25,00	32,00
	Drehzahl n (min⁻¹) / Revolution per minute n (min⁻¹)								
20	637	531	455	425	398	354	318	255	199
25	796	663	569	531	498	442	398	318	249
30	955	796	682	637	597	531	478	382	299
40	1274	1062	910	849	796	708	637	510	398
50	1592	1327	1137	1062	995	885	796	637	498
60	1911	1592	1365	1274	1194	1062	955	764	597
80	2548	2123	1820	1699	1592	1415	1274	1019	796
100	3185	2654	2275	2123	1990	1769	1592	1274	995
125	3981	3317	2843	2654	2488	2212	1990	1592	1244
150	4777	3981	3412	3185	2986	2654	2389	1911	1493
175	5573	4644	3981	3715	3483	3096	2787	2229	1742
200	6369	5308	4550	4246	3981	3539	3185	2548	1990
250	7962	6635	5687	5308	4976	4423	3981	3185	2488
300	9554	7962	6824	6369	5971	5308	4777	3822	2986
400	12739	10616	9099	8493	7962	7077	6369	5096	3981
450	14331	11943	10237	9554	8957	7962	7166	5732	4479
500	15924	13270	11374	10616	9952	8846	7962	6369	4976
600	19108	15924	13649	12739	11943	10616	9554	7643	5971
800	25478	21231	18198	16985	15924	14154	12739	10191	7962
1000	31847	26539	22748	21231	19904	17693	15924	12739	9952

Schnittgeschwindigkeiten - (Richtwerte) für Cerin Fräswerkzeuge

Approximative values of cutting speed for milling machines

Werkstoff Gruppe	Werkstoff Bezeichnung	Festigkeit N/mm ²	VHM V _c (m/min)	
Material Group	Material Description	Strength N/mm ²	Carbide	Coating
Aluminium - Alu-Legierungen - Kupfer - Kupferlegierungen - Magnesium <i>Aluminium - Aluminium alloys - Copper - Copper alloys - Magnesium</i>				Cer-Al
A 1.1	G-AlMg3	130 - 190	220	500
A 1.2	Al 99.5 / F13	100 - 250	300	600
A 1.3	GDAlSi17Cu4	180 - 250		200
A 1.4	GD-AlSi12	220 - 300		280
A 1.5	GD-AlSi9Cu3	240 - 320		280
A 1.6	AlCuMg1 / F39	300-500	300	600
A1.7	MMC - LM-Legierung - faserarmiert		220	300
A 2.1	E-Cu	220 - 350	200	250
A 2.2	GCuSn5ZnPb / Rg5	150 - 350	220	300
A 2.3	GCuSn7ZnPb / Rg7	150 - 350	220	300
A 2.4	CuZn40 /Ms60	340 - 500	220	250
A 2.5	CuZn39Pb2 / Ms58	350-500	350	500
A 2.6	CuZn37 /Ms63	300 - 550	200	250
A 2.7	CuAl10Ni	500 - 800	150	250
A 3.1	Ampco 16	630		65
A 3.2	Ampco 20	600		25
A 4.1	MgAl6	300 - 500	200	280
A 4.2	GMgAl9Zn1	300 - 500	180	260
Kunststoffe - Faserverstärkte Kunststoffe - NE Werkstoffe <i>Plastics - Reinforced plastic fibres - Nonferrous materials</i>				Cer-P
B 1.1	Duroplaste / Thermosets	80 - 110	200	400
B 1.2	Thermoplaste / Thermoplastics	≤ 80	250	500
B 1.3	Polykarbonate / Polycarbonate		150	300
B 1.4	CFK-GFK-AFK	800 - 1500	120	180
B 1.5	Plexiglas / Plexiglass	≤ 255	150	300
B 2.1	Hartholz / Hard wood	≤ 255	200	300
B 2.2	Hartgummi / Hard rubber		60	100
B 2.3	NE-Metalle / Nonferrous metals	≤ 255	200	300
B 2.4	Presskarton / Pressed carton	≤ 255	200	250
Allgemeine Stahlwerkstoffe - Stahllegierungen - gehärtete Stähle <i>General steels - Steel alloys - Hardened steels</i>				Cer-T
C 1.1	Q-St-37-3	< 400	200	250
C 1.2	R-Fe80	< 400	200	250
C 1.3	9SMnPb28	500 - 700	150	200
C 1.4	St37-2	320 - 470	150	200
C 1.5	16MnCr5	500 - 700	100	150
C 1.6	Ck45	600 - 800	100	150
C 1.7	Gs25CrMo4	650 - 950	100	180
C 1.8	St70-2	700 - 900	120	180
C 2.1	100Cr6	700 - 900	100	150
C 2.2	X155CrVMo12-1	900 - 1100	80	120
C 2.3	X30WCrV5-3	1100	80	120
C 2.4	42CrMo4V	1200 - 1400	80	120
C 3.1	X38CrMoV5-3	900 - 1100	80	120
C 3.2	55NiCrMoV6	47 - 52 HRC		100
C 3.3	45WCrV7	56 - 60 HRC		100
C 3.4	X155CrVMo12-1	60 - 63 HRC		80
C 3.5	X210CrW12	63 - 66 HRC		80
C 4.1	FeroTiC	800 - 900		40
C 4.2	Hardox500	1300 - 1400		30

Schnittgeschwindigkeiten - für Cerin Fräswerkzeuge (Richtwerte) Approximative values of cutting speed for milling machines

Werkstoff Gruppe	Werkstoff Bezeichnung	Festigkeit N/mm ²	VHM V _c (m/min)	Cer-T
Material Group	Material Description	Strength N/mm ²	Carbide	Coating
Rost- und säurebeständige Stähle - VA Stähle <i>Corrosion and acid resistant steels - Heat resistant steels</i>				
D 1.1	X10NiCrAlTi32-20 (INCOLOY800)	610 - 850		90
D 1.2	X12CrNiTi18-9	500 - 700		90
D 1.3	X6CrNiMoTi17-12-2	500 - 730		90
D 1.4	X45SiCr4	900 - 1100		70
D 1.5	X5NiCrTi26-15	1200		50
Nickel/Kobalt Legierungen - Titan - Titan Legierungen <i>Nickel/Cobalt alloys - Titanium - Titanium alloys</i>				
E 1.1	Ti3 (Ti99.4)	700	100	120
E 1.2	TiAl6V4	700 - 900	80	100
E 1.3	TiAlMo4Sn2	900 - 1250		80
E 2.1	NiCu30Fe (MONEL400I)	420 - 610		70
E 2.2	NiCr19NbMo (INCONEL718)	850-1200		60
E 2.3	Haynes 25 (L605)	1550 - 2000		40
Gußwerkstoffe <i>Cast irons</i>				
F 1.1	GG 20	120-220 HB	140	160
F 1.2	GG 30	220 - 270 HB	120	150
F 1.4	Hartguß / <i>Hard cast iron</i>	< 400 HB		80
F 1.2	GTW40	360 - 420	120	160
F 1.3	GTS65	560 - 650	100	150
F 2.1	GGG 40	400	120	150
F 2.2	GGG 70	700 - 1050	100	150
F 2.3	GGV (80% Perlit)	220 HB	80	100
F 2.4	GGV (100% Perlit)	230 HB	70	100
Graphit - Wolfram/Kupferlegierungen <i>Graphite - Tungsten/cooper alloys</i>				
G 1.1	C-800	60		450
G 2.1	W-Cu 80/20	230-250 HV		400

PIKTOGRAMME (SYMBOLS) ERKLÄRUNG ICONS (SYMBOLS) DESCRIPTION

Hartmetall Qualität <i>Carbide grade</i>	HM CK10-30-UF Ultrafine	Hartbearbeitung von 44 bis 67 HRC <i>Hard milling from 44 to 67 HRC</i>	HRC 44-67
Hartmetall Qualität <i>Carbide grade</i>	HM CK05-10-MG Micrograin	Schaftausführung DIN 6535 HA <i>Shank according to DIN 6535HA</i>	HA
Hartmetall Qualität <i>Carbide grade</i>	HM CK10-20-MG Micrograin	Schaftausführung DIN 6535 HB <i>Shank according to DIN 6535 HB</i>	HB
Hartmetall Qualität <i>Carbide grade</i>	HM CK20-30-MG Micrograin	Schaftausführung DIN 6535 HA/HB <i>Shank according to DIN 6535 HA/HB</i>	HA HB
Werkzeugausführung nach Werksnorm <i>Cutting edge design acc. to internal standard</i>	WN	Hochleistungsfräsen <i>High Performance Cutting</i>	HPC
Werksnorm (WN) kurz <i>Internal standard short</i>	WN kurz	Hochgeschwindigkeitsfräsen <i>High speed cutting</i>	HSC
Werksnorm (WN) lang <i>Internal standard long</i>	WN lang	Baumasse nach DIN 6527-L <i>Dimensions acc. to DIN 6527-L</i>	DIN 6527-L
Werksnorm (WN) überlang <i>Internal standard extra long</i>	WN überlang	Baumasse nach DIN 6527-K <i>Dimensions acc. to DIN 6527-K</i>	DIN 6527-K
Werksnorm (WN) extra lang <i>Internal standard extra long</i>	WN extra lang	Baumasse nach DIN 6528 <i>Dimensions acc. to DIN 6528</i>	DIN 6528
WN-Sonderverzahnung gegenläufig <i>Internal standard - Counterwise special cut</i>	WN	Baumaße ähnlich DIN 6527-L <i>Dimensions similar to DIN 6527-L</i>	Sim. to DIN 6527-L
Spanbrecher <i>Chip breaker</i>	WN	mit Luft <i>With compressed air</i>	
Schruppkordel nach Werksnorm <i>Chip breaker</i>	WN	mit Kaltluftkühlung <i>With cold air coolant system</i>	
Hartbearbeitung bis 56 HRC <i>Hard milling up to 56 HRC</i>	HRC ≤ 56	MMS - MinimalMengenSchmierung <i>MQS - Minimum quantity lubrication</i>	

PIKTOGRAMME (SYMBOLS) ERKLÄRUNG ICONS (SYMBOLS) DESCRIPTION

02

mit Emulsion - Öl <i>With oil emulsion</i>		Spanwinkel <i>Rake angle</i>	
Trockenbearbeitung <i>Dry machining</i>		Bearbeitungsbeispiel <i>Application example</i>	
Spiralwinkel <i>Helix angle</i>		Bearbeitungsbeispiel <i>Application example</i>	
Spiralwinkel <i>Helix angle</i>		Bearbeitungsbeispiel <i>Application example</i>	
Spiralwinkel <i>Helix angle</i>		Bearbeitungsbeispiel <i>Application example</i>	
Spiralwinkel <i>Helix angle</i>		Bearbeitungsbeispiel <i>Application example</i>	
Spiralwinkel <i>Helix angle</i>		Bearbeitungsbeispiel <i>Application example</i>	
Spiralwinkel <i>Helix angle</i>		Vorschubrichtung <i>Feed direction</i>	
Spiralwinkel <i>Helix angle</i>		Vorschubrichtung <i>Feed direction</i>	
Spiralwinkel <i>Helix angle</i>		Vorschubrichtung <i>Feed direction</i>	
Spanwinkel <i>Rake angle</i>		Werkzeug - Länge <i>Tool length</i>	
Spanwinkel <i>Rake angle</i>		Werkzeug - Länge <i>Tool length</i>	
Spanwinkel <i>Rake angle</i>		Werkzeug - Länge <i>Tool length</i>	

PIKTOGRAMME (SYMBOLS) ERKLÄRUNG
ICONS (SYMBOLS) DESCRIPTION

Werkzeug - Länge <i>Tool length</i>		Unterschiedliche Spiralwinkel <i>Different helix angle</i>	
Werkzeug - Länge <i>Tool length</i>		Bearbeitungsbeispiel <i>Application example</i>	
Werkzeug - Länge <i>Tool length</i>		Bearbeitungsbeispiel <i>Application example</i>	
Werkzeug - Länge <i>Tool length</i>		Bearbeitungsbeispiel <i>Application example</i>	
Werkzeug - Länge <i>Tool length</i>		Bearbeitungsbeispiel <i>Application example</i>	
Radiusfräser <i>Ball nose cutters</i>		Bearbeitungsbeispiel <i>Application example</i>	
Eckenradius <i>Corner radius</i>		Gerade genutet <i>Straight flute</i>	
Gegenläufige Schneiden <i>Counterrotating cutting edges</i>			
Spannuten - feinstgeschliffen <i>with fine lapped chip flutes</i>			
Links/rechts Schneiden <i>Right/left cutting edges</i>			
Bearbeitungsbeispiel <i>Application example</i>			
Variabler Spiralwinkel <i>Variable helix angle</i>			
2 Unterschiedliche Spiralwinkel <i>2 different helix angles</i>			

02

02

Lined writing area with horizontal lines for text entry.



2.
02

Kopierfräser und Hartfräser
Copying milling cutters and milling cutters for hard materials

(5) RAIL SUPPORT

GEGENLAUFFRÄSEN

Hochgeschwindigkeitsfräsen bedeutet Verringerung der Bearbeitungszeiten und der Fertigungskosten, unter Verwendung von hohen Schnittgeschwindigkeiten und von sowohl radial als auch axial relativ reduzierten Schnitttiefen.

Die HSC Fräser weisen eine besonders optimierte Geometrie auf und werden mit Extrafeinkorn Hartmetall hergestellt.

HIGH SPEED CUTTING

High speed cutting means to reduce times and costs of production, by using extremely high speed cutting and depth of cut, both radial and axial, relatively reduced.

"HSC end mills" show a particularly appropriate geometry and are built with special hard metals, extra-fine grained.

RATSCHLÄGE FÜR DIE HSC BEARBEITUNG / USEFUL SUGGESTIONS FOR THE HSC METHOD

Wir empfehlen soweit wie möglich den Schnitt auf Zug.
Den größten Span erhält man über die optimale Schnittgeschwindigkeit.

*We recommend that pull cutting be used as much as possible.
The greater section of swarf corresponds to the optimum cutting speed.*

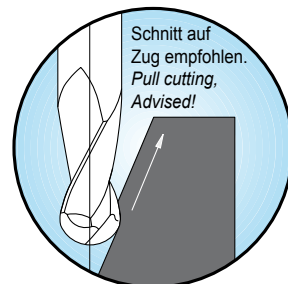

2.
02

Das Gleichlaufräsen ist qualitativ besser als das Gegenlaufräsen. Man erreicht eine bessere Oberflächenrauheit, weniger Geräusche und eine höhere Standzeit der Werkzeuge.

*Concordant milling gives a better quality result than discordant milling:
better surface roughness, less noise, and longer tool life.*

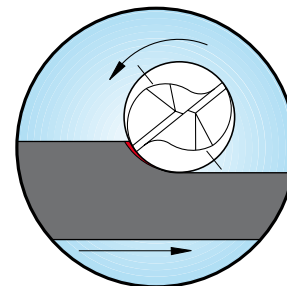

Man sollte den Fräser möglichst leicht in die Richtung des Vorschubs neigen, um die Bearbeitung im Zentrum des Werkzeugs zu vermeiden, wo die Schnittgeschwindigkeit gleich 0 ist.

If possible, the tools should be slightly tilted in the feed direction to avoid any working in the central part of the tool where the cutting speed is equal to 0.

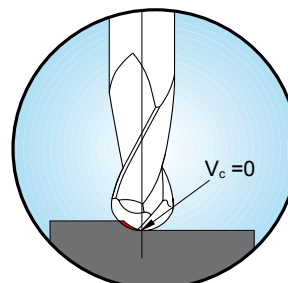

Die ideale Neigung ist 15° in Vorschubrichtung und erlaubt dem Fräser mit einer Schnittgeschwindigkeit von 80% der möglichen Höchstgeschwindigkeit zu arbeiten, bezogen auf den nominalen Durchmesser des Fräasers.

The ideal tilt is at 15° in the feed direction and allows the mill to work to a cutting speed equal to 80% of the maximum theoretical one in reference to the nominal diameter of the cutter itself.

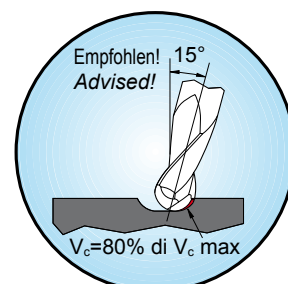

Keine senkrechten Tauchschnitte im Werkstück durchführen; wir schlagen spiralförmige oder Rampenbewegungen vor.

Do not carry out vertical movements of immersion in the piece; we recommend spiral or ramp movements.

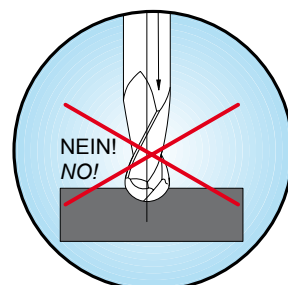

D_w (mm) - Arbeitsdurchmesser beim Kopier- und Zeilenfräsen

D_w (mm) - Working diameters for copy cutters and Z leveling cutters

Berechnungsformeln: Schnittgeschwindigkeit V_c (m/min) - Drehzahl n (min^{-1}) - Arbeitsbreite (eff. Durchmesser) D_w (mm)
 Calculation formula: Cutting speed V_c (m/min) - Revolution per minute n (min^{-1}) - Working width (eff. working diameter) D_w (mm)

$$V_c \text{ (m/min)} = \frac{D_w \text{ (mm)} \times 3,14 \times n \text{ (min}^{-1}\text{)}}{1000}$$

$$n \text{ (min}^{-1}\text{)} = \frac{V_c \text{ (m/min)} \times 1000}{D_w \text{ (mm)} \times 3,14}$$

D_w (mm) - Arbeitsdurchmesser (effektiv)
 D_w (mm) - Working diameter (effective)

$$D_w \text{ (mm)} = 2 \times \sqrt{a_p (D_c - a_p)}$$

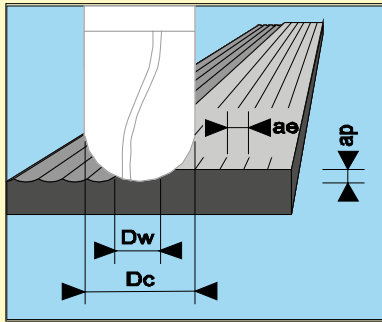

Arbeitsdurchmesser (neu) D_w (mm)
 Working diameter (new) D_w (mm)

2.
02

D_c (Ømm)	$a_p = D_c \times 0,05$		$a_p = D_c \times 0,10$		$a_p = D_c \times 0,15$		$a_p = D_c \times 0,20$		$a_p = D_c \times 0,25$		$a_p = D_c \times 0,30$	
	a_p (mm)	D_w (mm)	a_p (mm)	D_w (mm)	a_p (mm)	D_w (mm)	a_p (mm)	D_w (mm)	a_p (mm)	D_w (mm)	a_p (mm)	D_w (mm)
1,00	0,05	0,44	0,10	0,60	0,15	0,71	0,20	0,80	0,25	0,87	0,30	0,92
1,50	0,075	0,65	0,15	0,71	0,22	1,07	0,30	1,20	0,375	1,3	0,45	1,37
2,00	0,10	0,87	0,20	1,20	0,30	1,43	0,40	1,60	0,50	1,73	0,60	1,83
2,50	0,125	1,09	0,25	1,90	0,375	1,78	0,50	2,00	0,625	2,17	0,75	2,29
3,00	0,15	1,31	0,30	1,80	0,45	2,14	0,60	2,40	0,75	2,6	0,90	2,75
4,00	0,20	1,74	0,40	2,40	0,60	2,86	0,80	3,20	1,00	3,46	1,20	3,67
5,00	0,25	2,18	0,50	3,00	0,75	3,57	1,00	4,00	1,25	4,39	1,50	4,58
6,00	0,30	2,62	0,60	3,60	0,90	4,28	1,20	4,80	1,50	5,2	1,80	5,50
8,00	0,40	3,49	0,80	4,80	1,20	5,71	1,60	6,40	2,00	6,93	2,40	7,33
10,00	0,50	4,36	1,00	6,00	1,50	7,14	2,00	8,00	2,50	8,66	3,00	9,17
12,00	0,60	5,23	1,20	7,70	1,80	8,57	2,40	9,60	3,00	10,39	3,60	11,00
14,00	0,70	6,10	1,40	8,43	2,10	10,00	2,80	11,20	3,50	12,12	4,20	12,83
16,00	0,80	6,97	1,60	9,60	2,40	11,43	3,20	12,80	4,00	13,86	4,80	14,66
18,00	0,90	7,85	1,80	10,80	2,70	12,85	3,60	14,40	4,50	15,59	5,40	16,50
20,00	1,00	8,72	2,00	12,00	3,00	14,28	4,00	16,00	5,00	17,32	6,00	18,33

Schnittgeschwindigkeiten V_c (m/min) - Drehzahlen n (min^{-1})
Cutting speed V_c (m/min) - Revolution per minute n (min^{-1})

Berechnungsformeln: Schnittgeschwindigkeit V_c (m/min) - Drehzahl n (min^{-1})
Calculation formula: Cutting speed V_c (m/min) - Revolution per minute n (min^{-1})

$$V_c \text{ (m/min)} = \frac{D_w \text{ (mm)} \times 3,14 \times n \text{ (min}^{-1}\text{)}}{1000}$$

$$n \text{ (min}^{-1}\text{)} = \frac{V_c \text{ (m/min)} \times 1000}{D_w \text{ (mm)} \times 3,14}$$

Drehzahlen für Arbeitsdurchmesser D_w (mm)
Revolution per minute for working diameters D_w (mm)

D_w (mm)	V_c (m/min)									
	40	50	60	80	100	125	150	180	200	220
Drehzahl n (min^{-1}) / Revolution per minute n (min^{-1})										
0,3	42463	53079	6369	84926	106157	132696	159236			
0,4	31847	39809	4777	63694	79618	99522	119427	143312	159236	175159
0,5	25478	31847	3822	50955	63694	79618	95541	114650	127389	140127
0,6	21231	26539	3185	42463	53079	66348	79618	95541	106157	116773
0,7	18198	22748	2730	36397	45496	56870	68244	81893	90992	100091
0,8	15924	19904	2389	31847	39809	49761	59713	71656	79618	87580
0,9	14154	17693	2123	28309	35386	44232	53079	63694	70771	77849
1	12739	15924	1911	25478	31847	39809	47771	57325	63694	70064
1,1	11581	14476	1737	23162	28952	36190	43428	52113	57904	63694
1,2	10616	13270	1592	21231	26539	33174	39809	47771	53079	58386
1,3	9799	12249	1470	19598	24498	30622	36747	44096	48996	53895
1,4	9099	11374	1365	18198	22748	28435	34122	40946	45496	50045
1,5	8493	10616	1274	16985	21231	26539	31847	38217	42463	46709
1,6	7962	9952	1194	15924	19904	24881	29857	35828	39809	43790
1,8	7077	8846	1062	14154	17693	22116	26539	31847	35386	38924
2	6369	7962	955	12739	15924	19904	23885	28662	31847	35032
2,2	5790	7238	869	11581	14476	18095	21714	26057	28952	31847
2,4	5308	6635	796	10616	13270	16587	19904	23885	26539	29193
2,6	4900	6124	735	9799	12249	15311	18373	22048	24498	26948
2,8	4550	5687	682	9099	11374	14217	17061	20473	22748	25023
3,2	3981	4976	597	7962	9952	12440	14928	17914	19904	21895
3,4	3747	4683	562	7493	9367	11709	14050	16860	18734	20607
3,6	3539	4423	531	7077	8846	11058	13270	15924	17693	19462
3,8	3352	4190	503	6705	8381	10476	12571	15085	16762	18438
4	3185	3981	478	6369	7962	9952	11943	14331	15924	17516
4,3	2963	3703	444	5925	7406	9258	11109	13331	14813	16294
4,6	2769	3462	415	5539	6923	8654	10385	12462	13847	15231
5	2548	3185	382	5096	6369	7962	9554	11465	12739	14013
5,5	2316	2895	347	4632	5790	7238	8686	10423	11581	12739
6	2123	2654	318	4246	5308	6635	7962	9554	10616	11677
6,5	1960	2450	294	3920	4900	6124	7349	8819	9799	10779
7	1820	2275	273	3640	4550	5687	6824	8189	9099	10009
7,5	1699	2123	255	3397	4246	5308	6369	7643	8493	9342
8	1592	1990	239	3185	3981	4976	5971	7166	7962	8758
8,5	1499	1873	225	2997	3747	4683	5620	6744	7493	8243
9	1415	1769	212	2831	3539	4423	5308	6369	7077	7785
9,5	1341	1676	201	2682	3352	4190	5028	6034	6705	7375
10	1274	1592	191	2548	3185	3981	4777	5732	6369	7006
10,5	1213	1517	182	2426	3033	3791	4550	5460	6066	6673
11	1158	1448	174	2316	2895	3619	4343	5211	5790	6369
11,5	1108	1385	166	2215	2769	3462	4154	4985	5539	6092
12	1062	1327	159	2123	2654	3317	3981	4777	5308	5839
13	980	1225	147	1960	2450	3062	3675	4410	4900	5390
14	910	1137	136	1820	2275	2843	3412	4095	4550	5005
15	849	1062	127	1699	2123	2654	3185	3822	4246	4671
16	796	995	119	1592	1990	2488	2986	3583	3981	4379

Schnittgeschwindigkeiten V_c (m/min) - Drehzahlen n (min⁻¹)
Cutting speed V_c (m/min) - Revolution per minute n (min⁻¹)

Berechnungsformeln: Schnittgeschwindigkeit V_c (m/min) - Drehzahl n (min⁻¹)
Calculation formula: Cutting speed V_c (m/min) - Revolution per minute n (min⁻¹)

$$V_c \text{ (m/min)} = \frac{D_w \text{ (mm)} \times 3,14 \times n \text{ (min}^{-1}\text{)}}{1000}$$

$$n \text{ (min}^{-1}\text{)} = \frac{V_c \text{ (m/min)} \times 1000}{D_w \text{ (mm)} \times 3,14}$$

Drehzahlen für Arbeitsdurchmesser D_w (mm)
Revolution per minute for working diameters D_w (mm)

D_w (mm)	V_c (m/min)										
	250	300	350	400	450	500	550	600	650	700	750
Drehzahl n (min ⁻¹) / Revolution per minute n (min ⁻¹)											
0,3											
0,4											
0,5	159236										
0,6	132696	159236									
0,7	113740	136488	159236								
0,8	99522	119427	139331	159236							
0,9	88464	106157	123850	141543	159236						
1	79618	95541	111465	127389	143312	159236					
1,1	72380	86856	101332	115808	130284	144760	159236				
1,2	66348	79618	92887	106157	119427	132696	145966	159236			
1,3	61244	73493	85742	97991	110240	122489	134738	146987	159236		
1,4	56870	68244	79618	90992	102366	113740	125114	136488	147862	159236	
1,5	53079	63694	74310	84926	95541	106157	116773	127389	138004	148620	159236
1,6	49761	59713	69666	79618	89570	99522	109475	119427	129379	139331	149283
1,8	44232	53079	61925	70771	79618	88464	97311	106157	115004	123850	132696
2	39809	47771	55732	63694	71656	79618	87580	95541	103503	111465	119427
2,2	36190	43428	50666	57904	65142	72380	79618	86856	94094	101332	108570
2,4	33174	39809	46444	53079	59713	66348	72983	79618	86253	92887	99522
2,6	30622	36747	42871	48996	55120	61244	67369	73493	79618	85742	91867
2,8	28435	34122	39809	45496	51183	56870	62557	68244	73931	79618	85305
3,2	24881	29857	34833	39809	44785	49761	54737	59713	64689	69666	74642
3,4	23417	28100	32784	37467	42151	46834	51517	56201	60884	65568	70251
3,6	22116	26539	30962	35386	39809	44232	48655	53079	57502	61925	66348
3,8	20952	25142	29333	33523	37714	41904	46095	50285	54475	58666	62856
4	19904	23885	27866	31847	35828	39809	43790	47771	51752	55732	59713
4,3	18516	22219	25922	29625	33328	37032	40735	44438	48141	51844	55547
4,6	17308	20770	24232	27693	31155	34616	38078	41540	45001	48463	51925
5	15924	19108	22293	25478	28662	31847	35032	38217	41401	44586	47771
5,5	14476	17371	20266	23162	26057	28952	31847	34742	37638	40533	43428
6	13270	15924	18577	21231	23885	26539	29193	31847	34501	37155	39809
6,5	12249	14699	17148	19598	22048	24498	26948	29397	31847	34297	36747
7	11374	13649	15924	18198	20473	22748	25023	27298	29572	31847	34122
7,5	10616	12739	14862	16985	19108	21231	23355	25478	27601	29724	31847
8	9952	11943	13933	15924	17914	19904	21895	23885	25876	27866	29857
8,5	9367	11240	13114	14987	16860	18734	20607	22480	24354	26227	28100
9	8846	10616	12385	14154	15924	17693	19462	21231	23001	24770	26539
9,5	8381	10057	11733	13409	15085	16762	18438	20114	21790	23466	25142
10	7962	9554	11146	12739	14331	15924	17516	19108	20701	22293	23885
10,5	7583	9099	10616	12132	13649	15165	16682	18198	19715	21231	22748
11	7238	8686	10133	11581	13028	14476	15924	17371	18819	20266	21714
11,5	6923	8308	9693	11077	12462	13847	15231	16616	18001	19385	20770
12	6635	7962	9289	10616	11943	13270	14597	15924	17251	18577	19904
13	6124	7349	8574	9799	11024	12249	13474	14699	15924	17148	18373
14	5687	6824	7962	9099	10237	11374	12511	13649	14786	15924	17061
15	5308	6369	7431	8493	9554	10616	11677	12739	13800	14862	15924
16	4976	5971	6967	7962	8957	9952	10947	11943	12938	13933	14928

Kopierfräser - Einsatzdaten - Zahnvorschub f_z (mm) - Schnitttiefe a_p (mm) - Schnittbreite a_e (mm)
 Copy milling cutters - Cutting data - Feed per tooth f_z (mm) - Axial depth of cut a_p (mm) - Radial depth of cut a_e (mm)

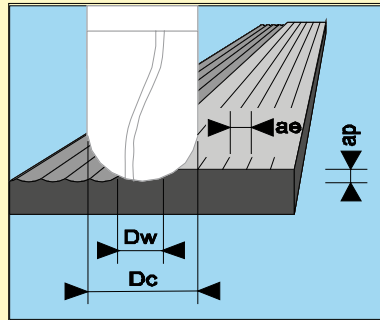

Kopieren a_e (mm) und a_p (mm)
 Copying a_e (mm) and a_p (mm)

Zahnvorschub f_z (mm) / Feed per tooth f_z (mm)
 Vorschub f (mm) / Feed per revolution f (mm)
 Vorschub V_f (mm/min) / Feed rate V_f (mm/min)

$f_z = D_c$ (mm) x Wert Tabelle / Value table
 $f = Z_n \times f_z$
 $V_f = n \times Z_n \times f_z$

2.
02

Gruppe A - Aluminium - Aluminiumlegierungen - Kupfer - Kupferlegierungen - Magnesium
 Group A - Aluminium - Aluminium alloys - Copper - Copper alloys - Magnesium

		Radiusfräser / Ball nose cutters						Torusfräser / Torus cutters					
		Schruppen Roughing			Schlichten Finishing			Schruppen Roughing			Schlichten Finishing		
		$a_p = D_c \times 0,1$ $a_e = D_c \times 0,2$			$a_p = D_c \times 0,02$			$a_p = D_c \times 0,1$ $a_e = D_c \times 0,2$			$a_p = D_c \times 0,02$		
		■ D_c (mm)			D_c (mm)			D_c (mm)			D_c (mm)		
$f_z =$	1,5-2,5	3,0-5,0	6,0-20	1,5-2,5	3,0-5,0	6,0-20	1,5-2,5	3,0-5,0	6,0-20	1,5-2,5	3,0-5,0	6,0-20	
A 1.1	$D_c \times$	0,009	0,014	0,018	0,009	0,014	0,018	0,009	0,014	0,016	0,009	0,014	0,018
A 1.2	$D_c \times$	0,010	0,015	0,019	0,010	0,015	0,019	0,010	0,015	0,017	0,010	0,015	0,019
A 1.3	$D_c \times$	0,008	0,012	0,015	0,008	0,012	0,015	0,008	0,012	0,014	0,008	0,012	0,015
A 1.4	$D_c \times$	0,007	0,010	0,013	0,007	0,010	0,013	0,007	0,010	0,012	0,007	0,010	0,013
A 1.5	$D_c \times$	0,008	0,013	0,016	0,008	0,013	0,016	0,008	0,013	0,014	0,008	0,013	0,016
A 1.6	$D_c \times$	0,010	0,015	0,019	0,010	0,015	0,019	0,010	0,015	0,017	0,010	0,015	0,019
A1.7	$D_c \times$	0,004	0,006	0,008	0,004	0,006	0,008	0,004	0,006	0,007	0,004	0,006	0,008
A 2.1	$D_c \times$	0,006	0,010	0,012	0,006	0,010	0,012	0,006	0,010	0,011	0,006	0,010	0,012
A 2.2	$D_c \times$	0,006	0,010	0,012	0,006	0,010	0,012	0,006	0,010	0,011	0,006	0,010	0,012
A 2.3	$D_c \times$	0,006	0,010	0,012	0,006	0,010	0,012	0,006	0,010	0,011	0,006	0,010	0,012
A 2.4	$D_c \times$	0,006	0,009	0,011	0,006	0,009	0,011	0,006	0,009	0,010	0,006	0,009	0,011
A 2.5	$D_c \times$	0,006	0,009	0,011	0,006	0,009	0,011	0,006	0,009	0,010	0,006	0,009	0,011
A 2.6	$D_c \times$	0,006	0,009	0,011	0,006	0,009	0,011	0,006	0,009	0,010	0,006	0,009	0,011
A 2.7	$D_c \times$	0,006	0,010	0,012	0,006	0,010	0,012	0,006	0,010	0,011	0,006	0,010	0,012
A 3.1	$D_c \times$	0,005	0,008	0,010	0,005	0,008	0,010	0,005	0,008	0,009	0,005	0,008	0,010
A 3.2	$D_c \times$	0,004	0,006	0,007	0,004	0,006	0,007	0,004	0,006	0,006	0,004	0,006	0,007
A 4.1	$D_c \times$	0,009	0,014	0,018	0,009	0,014	0,018	0,009	0,014	0,016	0,009	0,014	0,018
A 4.2	$D_c \times$	0,010	0,015	0,019	0,010	0,015	0,019	0,010	0,015	0,017	0,010	0,015	0,019

■ Diese Richtwerte sollten immer der Maschine, dem Werkzeug und Werkstück angepasst werden.
 ■ These approx. values always should be adapted to machine, workpiece and tool.

Kopierfräser - Einsatzdaten - Zahnvorschub f_z (mm) - Schnitttiefe a_p (mm) - Schnittbreite a_e (mm)
Copy milling cutters - Cutting data - Feed per tooth f_z (mm) - Axial depth of cut a_p (mm) - Radial depth of cut a_e (mm)

Gruppe B - Kunststoffe - Faserverstärkte Kunststoffe - Ne Werkstoffe													
Group B - Plastics - Reinforced plastic fibres - Nonferrous materials													
		Radiusfräser / Ball nose cutters						Torusfräser / Torus cutters					
		Schruppen Roughing			Schlichten Finishing			Schruppen Roughing			Schlichten Finishing		
		$a_p = D_c \times 0,1$ $a_e = D_c \times 0,2$			$a_p = D_c \times 0,02$			$a_p = D_c \times 0,1$ $a_e = D_c \times 0,2$			$a_p = D_c \times 0,02$		
		■ D_c (mm)			■ D_c (mm)			■ D_c (mm)			■ D_c (mm)		
$f_z =$		1,0-2,5	3,0-5,0	6,0-20	1,0-2,5	3,0-5,0	6,0-20	1,0-2,5	3,0-5,0	6,0-20	1,0-2,5	3,0-5,0	6,0-20
B 1.1	$D_c \times$	0,010	0,018	0,020	0,008	0,012	0,016	0,010	0,016	0,018	0,010	0,008	0,014
B 1.2	$D_c \times$	0,009	0,016	0,018	0,007	0,011	0,014	0,009	0,014	0,016	0,009	0,007	0,013
B 1.3	$D_c \times$	0,010	0,018	0,020	0,008	0,012	0,016	0,010	0,016	0,018	0,010	0,008	0,014
B 1.4	$D_c \times$	0,005	0,009	0,010	0,004	0,006	0,008	0,005	0,008	0,009	0,005	0,004	0,007
B 1.5	$D_c \times$	0,010	0,018	0,020	0,008	0,012	0,016	0,010	0,016	0,018	0,010	0,008	0,014
B 2.1	$D_c \times$	0,006	0,011	0,012	0,005	0,007	0,010	0,006	0,010	0,011	0,006	0,005	0,008
B 2.2	$D_c \times$	0,005	0,009	0,010	0,004	0,006	0,008	0,005	0,008	0,009	0,005	0,004	0,007
B 2.3	$D_c \times$	0,008	0,014	0,016	0,006	0,010	0,013	0,008	0,013	0,014	0,008	0,006	0,011
B 2.4	$D_c \times$	0,007	0,012	0,013	0,005	0,008	0,010	0,007	0,010	0,012	0,007	0,005	0,009
Gruppe C - Allgemeine Stahlwerkstoffe - Stahllegierungen - gehärtete Stähle													
Group C - General steels - Steel alloys - Hardened steels													
C 1.1	$D_c \times$	0,006	0,011	0,012	0,005	0,007	0,010	0,006	0,010	0,011	0,006	0,005	0,008
C 1.2	$D_c \times$	0,006	0,011	0,012	0,005	0,007	0,010	0,006	0,010	0,011	0,006	0,005	0,008
C 1.3	$D_c \times$	0,006	0,011	0,012	0,005	0,007	0,010	0,006	0,010	0,011	0,006	0,005	0,008
C 1.4	$D_c \times$	0,006	0,011	0,012	0,005	0,007	0,010	0,006	0,010	0,011	0,006	0,005	0,008
C 1.5	$D_c \times$	0,005	0,009	0,010	0,004	0,006	0,008	0,005	0,008	0,009	0,005	0,004	0,007
C 1.6	$D_c \times$	0,005	0,009	0,010	0,004	0,006	0,008	0,005	0,008	0,009	0,005	0,004	0,007
C 1.7	$D_c \times$	0,006	0,010	0,011	0,004	0,007	0,009	0,006	0,009	0,010	0,006	0,004	0,008
C 1.8	$D_c \times$	0,006	0,010	0,011	0,004	0,007	0,009	0,006	0,009	0,010	0,006	0,004	0,008
C 2.1	$D_c \times$	0,005	0,009	0,010	0,004	0,006	0,008	0,005	0,008	0,009	0,005	0,004	0,007
C 2.2	$D_c \times$	0,004	0,007	0,008	0,003	0,005	0,006	0,004	0,006	0,007	0,004	0,003	0,006
C 2.3	$D_c \times$	0,004	0,007	0,008	0,003	0,005	0,006	0,004	0,006	0,007	0,004	0,003	0,006
C 2.4	$D_c \times$	0,004	0,007	0,008	0,003	0,005	0,006	0,004	0,006	0,007	0,004	0,003	0,006
C 3.1	$D_c \times$	0,004	0,007	0,008	0,003	0,005	0,006	0,004	0,006	0,007	0,004	0,003	0,006
C 4.1	$D_c \times$	0,004	0,006	0,007	0,003	0,004	0,006	0,004	0,006	0,006	0,004	0,003	0,005
C 4.2	$D_c \times$	0,004	0,006	0,007	0,003	0,004	0,006	0,004	0,006	0,006	0,004	0,003	0,005

2.
02

Gehärtete Stähle											
Hardened steels											
≤ 52 HRC				≤ 57 HRC				≤ 63 HRC		≤ 66 HRC	
		Radiusfräser Ball nose cutters				Torusfräser Torus cutters				Mehrschneider Multiflute cutters	
		$a_p = D_c \times 0,02$				$a_p = D_c \times 0,02$				$a_p = D_c \times 1,5$ $a_e = D_c \times 0,02$	
		■ D_c (mm)				■ D_c (mm)				■ D_c (mm)	
$f_z =$		1,0-2,0	3,0-5,0	6,0-10	12-20	1,0-2,0	3,0-5,0	6,0-10	12-20	3,0 - 25,0	
C 3.2	$D_c \times$	0,004	0,004	0,006	0,005	0,004	0,003	0,004	0,004	0,00175	
C 3.3	$D_c \times$	0,006	0,007	0,009	0,008	0,006	0,004	0,006	0,007	0,00275	
C 3.4	$D_c \times$	0,005	0,006	0,008	0,007	0,005	0,004	0,005	0,006	0,0025	
C 3.5	$D_c \times$	0,005	0,005	0,007	0,006	0,005	0,004	0,005	0,005	0,0025	

- Diese Richtwerte sollten immer der Maschine, dem Werkzeug und Werkstück angepasst werden.
- These approx. values always should be adapted to machine, workpiece and tool.

Kopierfräser - Einsatzdaten - Zahnvorschub f_z (mm) - Schnitttiefe a_p (mm) - Schnittbreite a_e (mm)
Copy milling cutters - Cutting data - Feed per tooth f_z (mm) - Axial depth of cut a_p (mm) - Radial depth of cut a_e (mm)

Gruppe D - Rost- Säure- und Hitzebeständige Stähle													
Group D - Corrosion and acid resistant steels - Heat resistant steels													
		Radiusfräser / Ball nose cutters						Torusfräser / Torus cutters					
		Schruppen Roughing			Schlichten Finishing			Schruppen Roughing			Schlichten Finishing		
		$a_p = D_c \times 0,1$ $a_e = D_c \times 0,2$			$a_p = D_c \times 0,02$			$a_p = D_c \times 0,1$ $a_e = D_c \times 0,2$			$a_p = D_c \times 0,02$		
		▣ D_c (mm)			▣ D_c (mm)			▣ D_c (mm)			▣ D_c (mm)		
$f_z =$	1,5-2,5	3,0-5,0	6,0-20	1,5-2,5	3,0-5,0	6,0-20	1,5-2,5	3,0-5,0	6,0-20	1,5-2,5	3,0-5,0	6,0-20	
D 1.1	$D_c \times$	0,005	0,009	0,100	0,004	0,006	0,008	0,005	0,008	0,009	0,005	0,004	0,007
D 1.2	$D_c \times$	0,005	0,009	0,100	0,004	0,006	0,008	0,005	0,008	0,009	0,005	0,004	0,007
D 1.3	$D_c \times$	0,005	0,009	0,100	0,004	0,006	0,008	0,005	0,008	0,009	0,005	0,004	0,007
D 1.4	$D_c \times$	0,005	0,008	0,090	0,004	0,005	0,007	0,005	0,007	0,008	0,005	0,004	0,006
D 1.5	$D_c \times$	0,004	0,006	0,070	0,003	0,004	0,006	0,004	0,006	0,006	0,004	0,003	0,005
Gruppe E - Nickel-/ Kobaltlegierungen - Titan-/ Titanlegierungen													
Group E - Nickel-/ Cobalt alloys - Titanium - Titanium alloys													
E 1.1	$D_c \times$	0,005	0,009	0,010	0,004	0,006	0,008	0,005	0,008	0,009	0,005	0,004	0,007
E 1.2	$D_c \times$	0,005	0,009	0,010	0,004	0,006	0,008	0,005	0,008	0,009	0,005	0,004	0,007
E 1.3	$D_c \times$	0,005	0,008	0,009	0,004	0,005	0,007	0,005	0,007	0,008	0,005	0,004	0,006
E 2.1	$D_c \times$	0,006	0,010	0,011	0,004	0,007	0,009	0,006	0,009	0,010	0,006	0,004	0,008
E 2.2	$D_c \times$	0,005	0,009	0,010	0,004	0,006	0,008	0,005	0,008	0,009	0,005	0,004	0,007
E 2.3	$D_c \times$	0,004	0,006	0,007	0,003	0,004	0,006	0,004	0,006	0,006	0,004	0,003	0,005
Gruppe F - Gußwerkstoffe													
Group F - Cast irons													
F 1.1	$D_c \times$	0,006	0,010	0,011	0,004	0,007	0,009	0,006	0,009	0,010	0,006	0,004	0,008
F 1.2	$D_c \times$	0,006	0,010	0,011	0,004	0,007	0,009	0,006	0,009	0,010	0,006	0,004	0,008
F 1.3	$D_c \times$	0,004	0,007	0,008	0,003	0,005	0,006	0,004	0,006	0,007	0,004	0,003	0,006
F 1.4	$D_c \times$	0,006	0,010	0,011	0,004	0,007	0,009	0,006	0,009	0,010	0,006	0,004	0,008
F 1.5	$D_c \times$	0,006	0,010	0,011	0,004	0,007	0,009	0,006	0,009	0,010	0,006	0,004	0,008
F 2.1	$D_c \times$	0,006	0,010	0,011	0,004	0,007	0,009	0,006	0,009	0,010	0,006	0,004	0,008
F 2.2	$D_c \times$	0,006	0,010	0,011	0,004	0,007	0,009	0,006	0,009	0,010	0,006	0,004	0,008
F 2.3	$D_c \times$	0,005	0,009	0,010	0,004	0,006	0,008	0,005	0,008	0,009	0,005	0,004	0,007
F 2.4	$D_c \times$	0,005	0,009	0,010	0,004	0,006	0,008	0,005	0,008	0,009	0,005	0,004	0,007
Gruppe G - Graphit - Wolfram - / Kupferlegierungen													
Group G - Graphite - Tungsten / Copper alloys													
G 1.1	$D_c \times$	0,006	0,010	0,011	0,004	0,007	0,009	0,006	0,009	0,010	0,006	0,004	0,008
G 2.1	$D_c \times$	0,006	0,010	0,011	0,004	0,007	0,009	0,006	0,009	0,010	0,006	0,004	0,008

 2.
02

▣ Diese Richtwerte sollten immer der Maschine, dem Werkzeug und Werkstück angepasst werden.
 ▣ These approx. values always should be adapted to machine, workpiece and tool.

Radius Kopierfräser - Z=2 Drall 40° - ähnlich DIN 6527-L

"ULTRA Ra" Speed Line mit feingeläppten Spannuten

Ball nose copy cutters - Z=2 Helix 40° - Similar to DIN 6527-L

"ULTRA Ra" Speed Line with fine lapped chip flutes

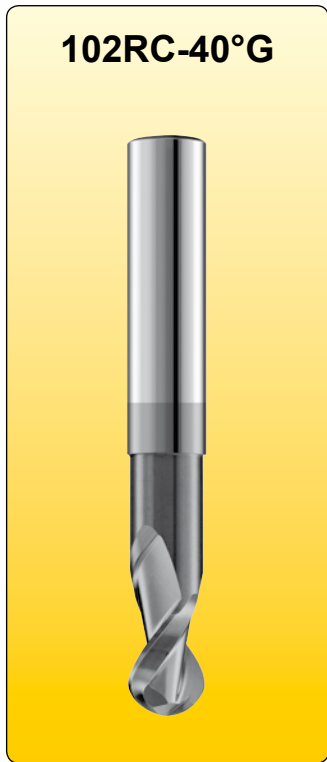
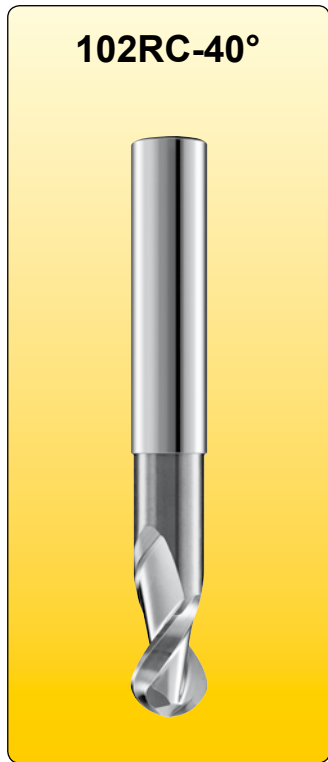
Einsatzgebiete / Range of application
A: Legierungen / Light alloys

A1.1-1.6 A2.1-2.6 A3.1-3.2 A4.1-4.2

B: Kunststoffe - Faserverstärkte Kunststoffe

 B: *Plastics - Reinforced plastic fibres*
 (GFK - CFK - AFK) - B1.1-1.6 B2.1-2.4

E: Titan / Titanium

E1.1-2.1

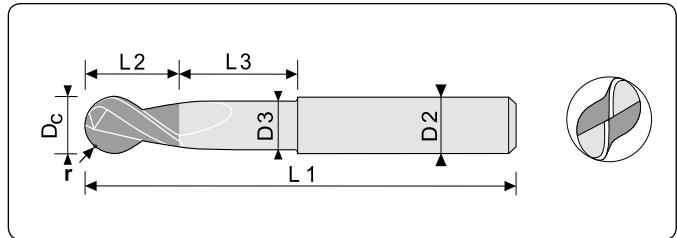
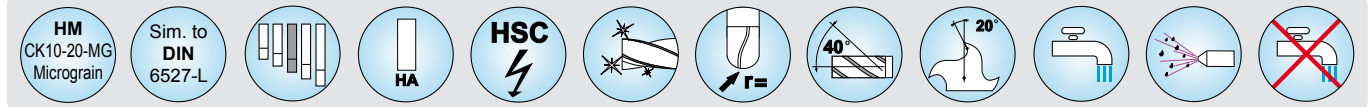
2.02

D _c h10	L2	L1	L3	D2 h6	D3	r	102RC-40°	102RC-40°G
								Beschichtet / Coated
2	4	57	2	6	1,8	1,0	102RC.020-40°	102RC.020-40°G
3	5	57	4	6	2,8	1,5	102RC.030-40°	102RC.030-40°G
4	6	57	6	6	3,7	2	102RC.040-40°	102RC.040-40°G
5	7	57	8	6	4,6	2,5	102RC.050-40°	102RC.050-40°G
6	8	57	12	6	5,5	3	102RC.060-40°	102RC.060-40°G
8	10	63	16	8	7,4	4	102RC.080-40°	102RC.080-40°G
10	12	72	19	10	9,2	5	102RC.100-40°	102RC.100-40°G
12	14	83	23	12	11	6	102RC.120-40°	102RC.120-40°G
14	16	83	25	14	13	7	102RC.140-40°	102RC.140-40°G
16	18	92	25	16	15	8	102RC.160-40°	102RC.160-40°G
20	22	104	31	20	19	10	102RC.200-40°	102RC.200-40°G

Radius Kopierfräser - Z=2 Drall 40° - WN extralang

“ULTRA Ra” Speed Line mit feingeläppten Spannuten

Ball nose copy cutters - Z=2 Helix 40° - Internal standard extra long

“ULTRA Ra” Speed Line with fine lapped chip flutes

2.
02

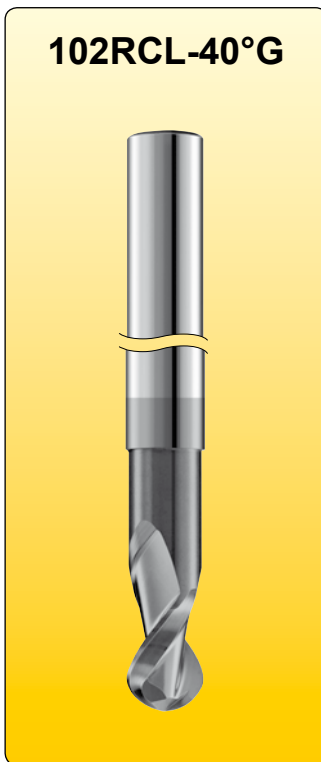
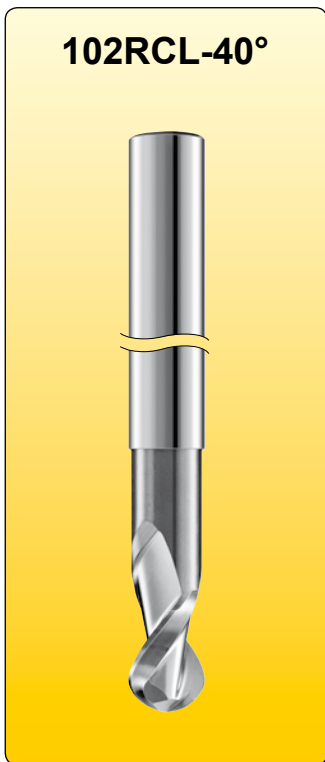

Einsatzgebiete / Range of application

A: Legierungen / Light alloys

A1.1-1.6 A2.1-2.6 A3.1-3.2 A4.1-4.2

B: Kunststoffe - Faserverstärkte Kunststoffe

B: Plastics - Reinforced plastic fibres
(GFK - CFK - AFK) - B1.1-1.6 B2.1-2.4

E: Titan / Titanium

E1.1-2.1

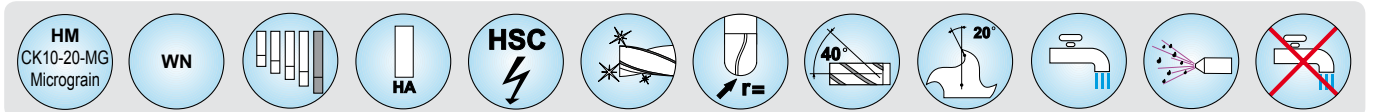
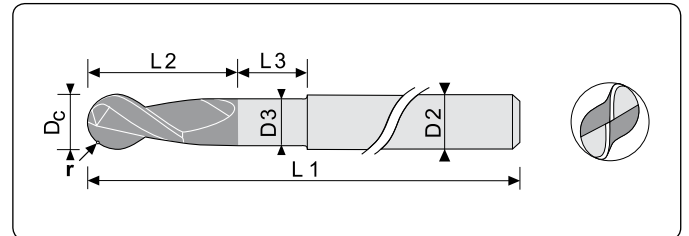

D _c h10	L2	L1	L3	D2 h6	D3	r	102RCL-40°	102RCL-40°G
								Beschichtet / Coated
3	6	100	44	6	2,8	1,5	102RCL.030-40°	102RCL.030-40°G
4	8	100	42	6	3,7	2	102RCL.040-40°	102RCL.040-40°G
5	10	100	40	6	4,6	2,5	102RCL.050-40°	102RCL.050-40°G
6	12	100	38	6	5,5	3	102RCL.060-40°	102RCL.060-40°G
8	16	100	34	8	7,4	4	102RCL.080-40°	102RCL.080-40°G
10	20	120	50	10	9,2	5	102RCL.100-40°	102RCL.100-40°G
12	24	150	76	12	11	6	102RCL.120-40°	102RCL.120-40°G
14	28	150	72	14	13	7	102RCL.140-40°	102RCL.140-40°G
16	32	150	68	16	15	8	102RCL.160-40°	102RCL.160-40°G
20	40	150	60	20	19	10	102RCL.200-40°	102RCL.200-40°G

Torus Kopierfräser - Z=2 Drall 40° - ähnlich DIN 6527-L

"ULTRA Ra" Speed Line mit feingeläppten Spannuten

Torus copy cutters - Z=2 Helix 40° - Similar to DIN 6527-L

"ULTRA Ra" Speed Line with fine lapped chip flutes

Einsatzgebiete / Range of application

A: Legierungen / Light alloys

A1.1-1.6 A2.1-2.6 A3.1-3.2 A4.1-4.2

B: Kunststoffe - Faserverstärkte Kunststoffe

 B: *Plastics - Reinforced plastic fibres*
 (GFK - CFK - AFK) - B1.1-1.6 B2.1-2.4

E: Titan / Titanium

E1.1-2.1

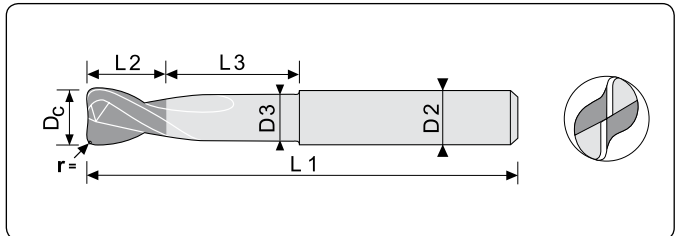
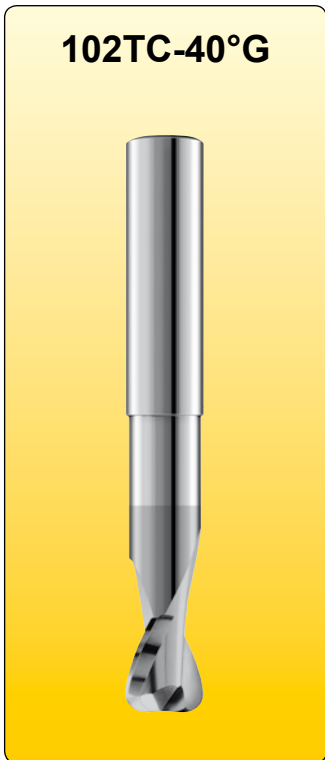
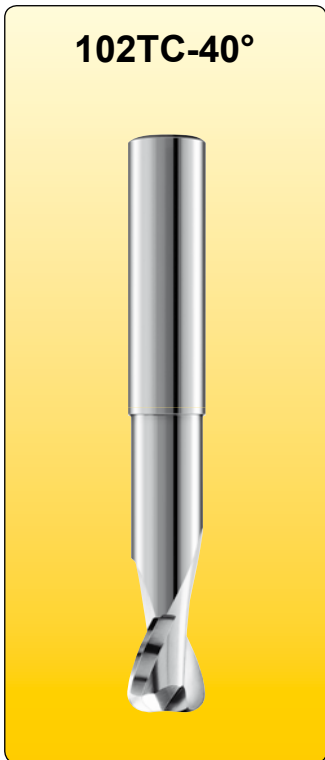
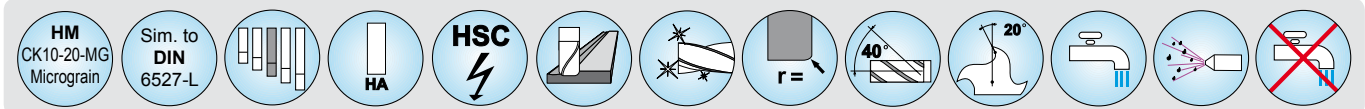
2.02

D _c h10	L2	L1	L3	D2 h6	D3	r	102TC-40°	102TC-40°G
								Beschichtet / Coated
2	4	57	2	6	1,8	0,5	102TC.020-40°	102TC.020-40°G
3	5	57	4	6	2,8	0,5	102TC.030-40°	102TC.030-40°G
4	6	57	6	6	3,7	0,5	102TC.040-40°	102TC.040-40°G
5	7	57	8	6	4,6	0,5	102TC.050-40°	102TC.050-40°G
6	8	57	12	6	5,5	1	102TC.060-40°	102TC.060-40°G
8	10	63	16	8	7,4	1	102TC.080-40°	102TC.080-40°G
10	12	72	19	10	9,2	1,5	102TC.100-40°	102TC.100-40°G
12	14	83	23	12	11	1,5	102TC.120-40°	102TC.120-40°G
14	16	83	25	14	13	2	102TC.140-40°	102TC.140-40°G
16	18	92	25	16	15	2	102TC.160-40°	102TC.160-40°G
20	22	104	31	20	19	2,5	102TC.200-40°	102TC.200-40°G

Torus Kopierfräser - Z=2 Drall 40° - WN extralang

"ULTRA Ra" Speed Line mit feingeläppten Spannuten

Torus copy cutters - Z=2 Helix 40° - Internal standard extra long

"ULTRA Ra" Speed Line with fine lapped chip flutes

102TCL-40°



102TCL-40°G



Einsatzgebiete / Range of application

A: Legierungen / Light alloys

A1.1-1.6 A2.1-2.6 A3.1-3.2 A4.1-4.2

B: Kunststoffe - Faserverstärkte Kunststoffe

B: *Plastics - Reinforced plastic fibres*

(GFK - CFK - AFK) - B1.1-1.6 B2.1-2.4

E: Titan / Titanium

E1.1-2.1

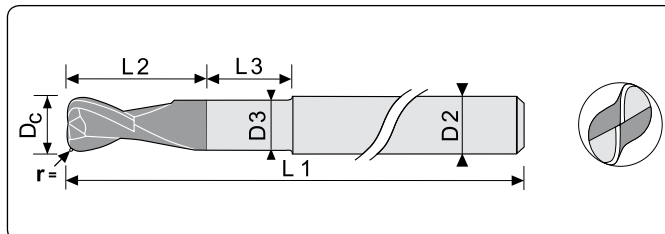

2.02

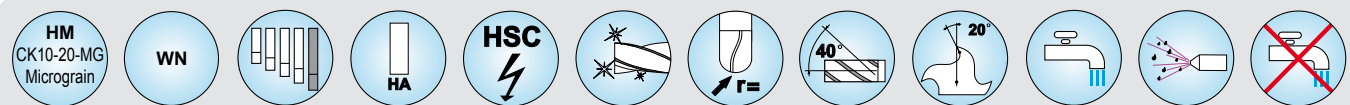

D _c h10	L2	L1	L3	D2 h6	D3	r	102TCL-40°	102TCL-40°G
								Beschichtet / Coated
3	6	100	44	6	2,8	0,5	102TCL.030-40°	102TCL.030-40°G
4	8	100	42	6	3,7	0,5	102TCL.040-40°	102TCL.040-40°G
5	10	100	40	6	4,6	0,5	102TCL.050-40°	102TCL.050-40°G
6	12	100	38	6	5,5	1	102TCL.060-40°	102TCL.060-40°G
8	16	100	34	8	7,4	1	102TCL.080-40°	102TCL.080-40°G
10	20	120	50	10	9,2	1,5	102TCL.100-40°	102TCL.100-40°G
12	24	150	76	12	11	1,5	102TCL.120-40°	102TCL.120-40°G
14	28	150	72	14	13	2	102TCL.140-40°	102TCL.140-40°G
16	32	150	68	16	15	2	102TCL.160-40°	102TCL.160-40°G
20	40	150	60	20	19	2,5	102TCL.200-40°	102TCL.200-40°G

Torus Kopierfräser - Z=2 Drall 30° - WN
Torus copy cutters - Z=2 Helix 30° - Internal standard

Einsatzgebiete / Range of application

A: Legierungen / Light alloys
 A1.7 A2.7 A3.1-3.2

C: Stahlwerkstoffe / Steels
 C1.1-1.8 C2.1-2.4 C3.1-3.2 C4.1-4.2

D: Edelstahl / Stainless steel
 D1.1-1.5

E: Titan / Titanium
 E1.2-1.3 E2.1-2.3

F: Gußeisen / Cast irons
 F1.1-1.5 F2.1-2.4

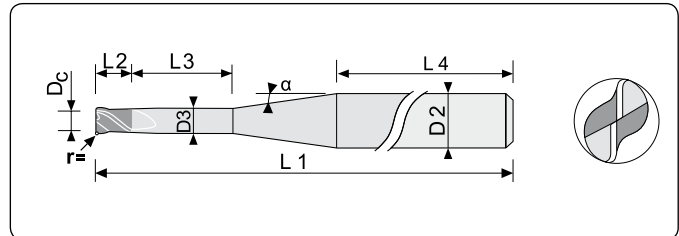
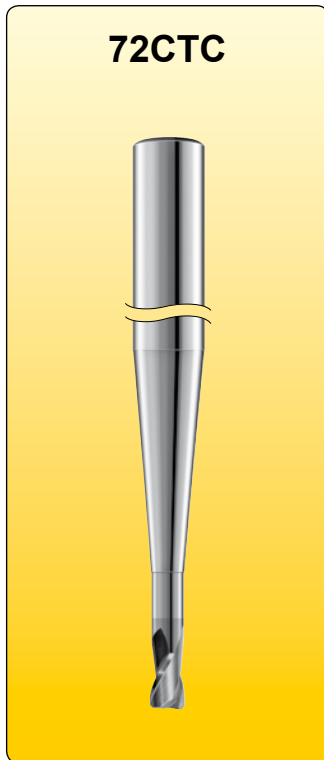
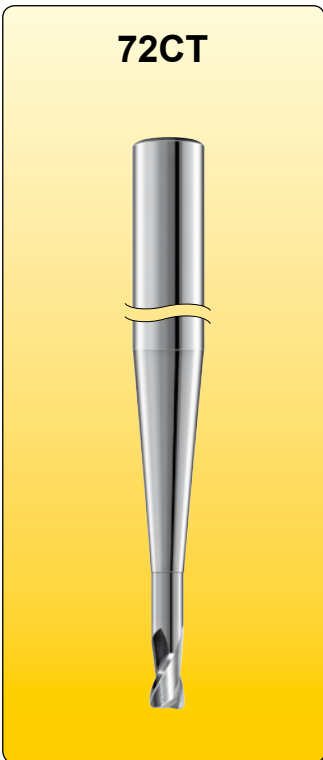

**2.
02**

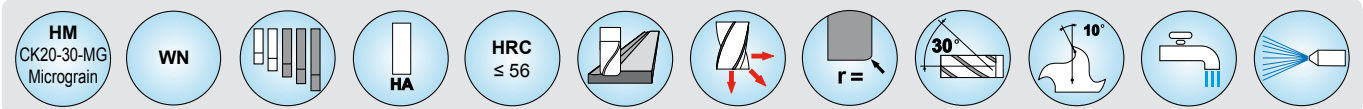

D _c h10	L2	L1	D2	L3	D3	L4	r	α	72CT	72CTC
										Beschichtet / Coated
1	2	50	4	2	0,9	30	0,1	5,53°	72CT.010040250	72CT.010040250C
1	2	57	6	2	0,9	30	0,1	6,33°	72CT.010060257	72CT.010060257C
1,5	2,5	50	4	2,5	1,4	30	0,1	4,95°	72CT.015042550	72CT.015042550C
1,5	2,5	57	6	2,5	1,4	30	0,1	5,98°	72CT.015062557	72CT.015062557C
2	3	50	4	3	1,9	30	0,2	4,29°	72CT.020040350	72CT.020040350C
2	3	57	6	3	1,9	30	0,2	5,58°	72CT.020060357	72CT.020060357C
2,5	3,5	50	4	3,5	2,4	30	0,3	3,52°	72CT.025043550	72CT.025043550C
2,5	3,5	57	6	3,5	2,4	30	0,3	5,14°	72CT.025063557	72CT.025063557C
3	3,5	50	4	3,5	2,8	30	0,5	2,42°	72CT.030043550	72CT.030043550C
3	4	80	6	4	2,8	40	0,5	2,86°	72CT.030060480	72CT.030060480C
4	5	57	6	6	3,8	30	0,6	3,93°	72CT.040060557	72CT.040060557C
4	6	80	6	6	3,8	40	0,5	2,25°	72CT.040060680	72CT.040060680C
5	7	57	6	7	4,8	30	0,5	2,64°	72CT.050060757	72CT.050060757C
5	7	80	6	7	4,8	40	0,5	1,32°	72CT.050060780	72CT.050060780C
6	9	100	8	9	5,8	40	1	1,50°	72CT.0600809100	72CT.0600809100C
6	10	120	10	9	5,8	50	1	2,31°	72CT.0601010120	72CT.0601010120C
8	12	120	10	12	7,8	50	1	1,37°	72CT.0801012120	72CT.0801012120C
8	12	150	12	12	7,8	60	1	1,82°	72CT.0801212150	72CT.0801212150C
10	14	150	12	14	9,8	60	1	1,02°	72CT.1001214150	72CT.1001214150C
10	14	150	14	14	9,8	60	1,5	1,94°	72CT.1001414150	72CT.1001414150C
12	16	150	14	16	11,8	60	1,5	1,09°	72CT.1201416150	72CT.1201416150C
12	16	150	16	16	11,8	60	1,5	2,07°	72CT.1201616150	72CT.1201616150C
16	20	150	20	20	15,8	60	2	2,41°	72CT.1602020150	72CT.1602020150C

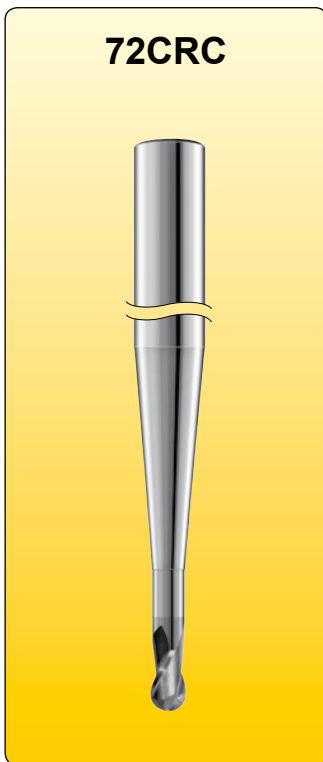
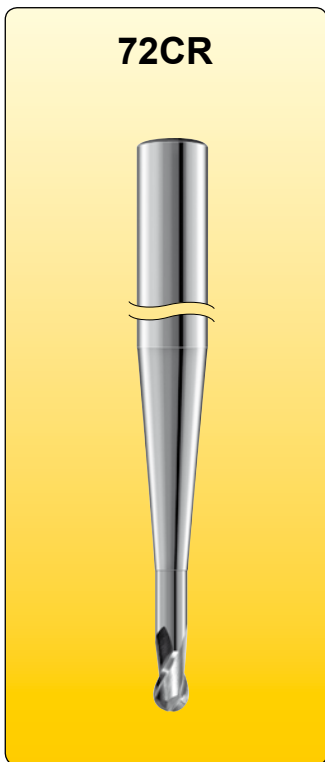
Radius Kopierfräser - Z=2 Drall 30° - WN
Ball nose copy cutters - Z=2 Helix 30° - Internal standard
**2.
02**

Einsatzgebiete / Range of application
A: Legierungen / Light alloys

A1.7 A2.7 A3.1-3.2

C: Stahlwerkstoffe / Steels

C1.1-1.8 C2.1-2.4 C3.1-3.2 C4.1-4.2

D: Edelstahl / Stainless steel

D1.1-1.5

E: Titan / Titanium

E1.2-1.3 E2.1-2.3

F: Gußeisen / Cast irons

F1.1-1.5 F2.1-2.4

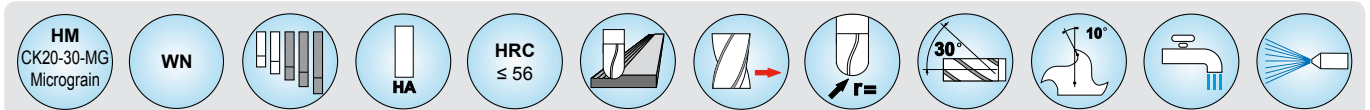
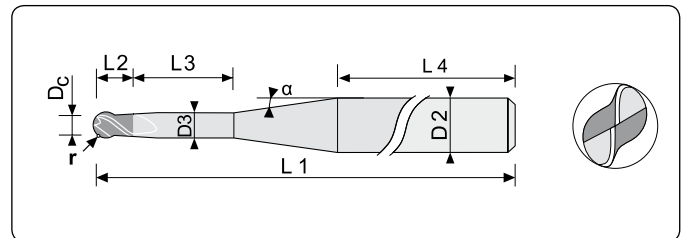

D _c h10	L2	L1	D2	L3	D3	L4	r	α	72CR	72CRC
										Beschichtet / Coated
1	2	50	4	2	0,9	30	0,5	5,53°	72CR.010040250	72CR.010040250C
1	2	57	6	2	0,9	30	0,5	6,33°	72CR.010060257	72CR.010060257C
1,5	2,5	50	4	2,5	1,4	30	0,75	4,95°	72CR.015042550	72CR.015042550C
1,5	2,5	57	6	2,5	1,4	30	0,75	5,98°	72CR.015062557	72CR.015062557C
2	3	50	4	3	1,9	30	1	4,29°	72CR.020040350	72CR.020040350C
2	3	57	6	3	1,9	30	1	5,58°	72CR.020060357	72CR.020060357C
2,5	3,5	50	4	3,5	2,4	30	1,25	3,52°	72CR.025043550	72CR.025043550C
2,5	3,5	57	6	3,5	2,4	30	1,25	5,14°	72CR.025063557	72CR.025063557C
3	3,5	50	4	3,5	2,8	30	1,5	2,42°	72CR.030043550	72CR.030043550C
3	4	80	6	4	2,8	40	1,5	2,86°	72CR.030060480	72CR.030060480C
4	5	57	6	6	3,8	30	0,5	3,93°	72CR.040060557	72CR.040060557C
4	6	80	6	6	3,8	40	2	2,25°	72CR.040060680	72CR.040060680C
5	7	57	6	7	4,8	30	0,5	2,64°	72CR.050060757	72CR.050060757C
5	7	80	6	7	4,8	40	2,5	1,32°	72CR.050060780	72CR.050060780C
6	9	100	8	9	5,8	40	3	1,50°	72CR.0600809100	72CR.0600809100C
6	10	120	10	9	5,8	50	3	2,31°	72CR.0601010120	72CR.0601010120C
8	12	120	10	12	7,8	50	4	1,37°	72CR.0801012120	72CR.0801012120C
8	12	150	12	12	7,8	60	4	1,82°	72CR.0801212150	72CR.0801212150C
10	14	150	12	14	9,8	60	5	1,02°	72CR.1001214150	72CR.1001214150C
10	14	150	14	14	9,8	60	5	1,94°	72CR.1001414150	72CR.1001414150C
12	16	150	14	16	11,8	60	6	1,09°	72CR.1201416150	72CR.1201416150C
12	16	150	16	16	11,8	60	6	2,07°	72CR.1201616150	72CR.1201616150C
16	20	150	20	20	15,6	60	8	2,41°	72CR.1602020150	72CR.1602020150C

Torusfräser - Z=2 Drall 30° - WN - für gehärtete Stähle
Torus cutters - Z=2 Helix 30° - Internal standard - for hardened steels

Einsatzgebiete / Range of application

 C:Stahlwerkstoffe / Steels
 C3.2-3.5

62THR

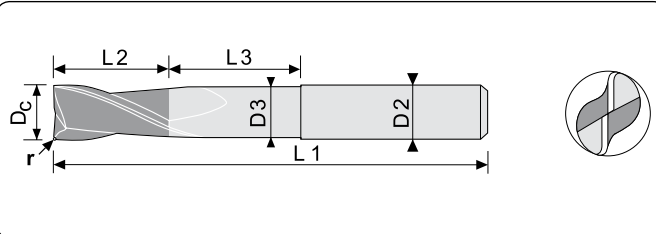
62THRB

**2.
02**

 HM
 CK10-30-UF
 Ultrafine

WN



 HRC
 44-67

D _c h10	L2	L1	D2 h6	D3	L3	r	62THR	62THRB
							■	Beschichtet / Coated
2	5	50	4	1,9	3	0,4	62THR.020040550	62THR.020040550B
3	6	60	6	2,9	6	0,5	62THR.030060660	62THR.030060660B
4	7	75	6	3,9	7	0,5	62THR.040060775	62THR.040060775B
5	8	75	6	4,9	8	0,5	62THR.050060875	62THR.050060875B
6	12	80	6	5,9	12	0,5	62THR.060061280	62THR.060061280B
8	14	100	8	7,8	15	1	62THR.0800814100	62THR.0800814100B
10	18	100	10	9,8	20	1	62THR.1001018100	62THR.1001018100B
12	22	105	12	11,8	22	1	62THR.1201222105	62THR.1201222105B
14	26	120	14	13,8	25	1,5	62THR.1401426120	62THR.1401426120B
16	30	150	16	15,8	30	1,5	62THR.1601630150	62THR.1601630150B
18	34	150	18	17,7	30	2	62THR.1801834150	62THR.1801834150B
20	38	150	20	19,7	30	2	62THR.2002038150	62THR.2002038150B

■ zur Eigenbeschichtung vorgesehen - ohne geeignete Beschichtung nicht einsetzbar.
 ■ provided for own coating. Not suitable without adapted coating.

Radiusfräser - Z=2 Drall 30° - WN - für gehärtete Stähle
Ball nose cutters - Z=2 Helix 30° - Internal standard - for hardened steels

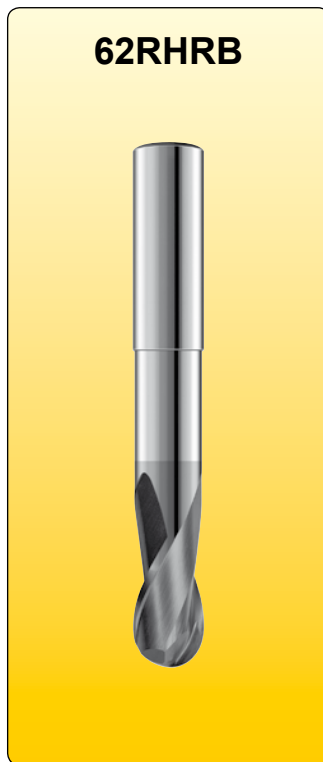
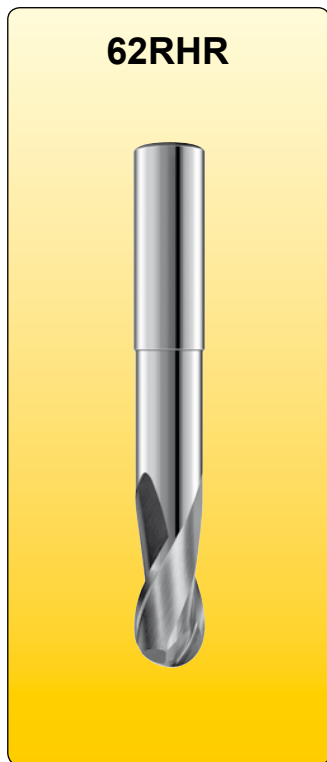
2.
02



Einsatzgebiete / Range of application

C:Stahlwerkstoffe / Steels
C3.2-3.5

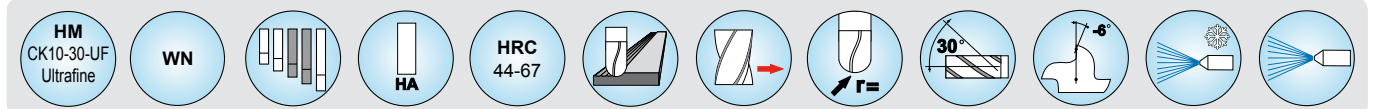
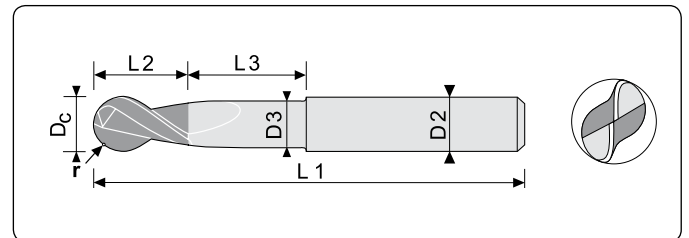

D _c h10	L2	L1	D2 h6	D3	L3	r	62RHR	62RHRB
							■	Beschichtet / Coated
2	5	50	4	1,9	3	1	62RHR.020040550	62RHR.020040550B
3	6	60	6	2,9	6	1,5	62RHR.030060660	62RHR.030060660B
4	7	75	6	3,9	7	2	62RHR.040060775	62RHR.040060775B
5	8	75	6	4,9	8	2,5	62RHR.050060875	62RHR.050060875B
6	12	80	6	5,9	12	3	62RHR.060061280	62RHR.060061280B
8	14	100	8	7,8	15	4	62RHR.0800814100	62RHR.0800814100B
10	18	100	10	9,8	20	5	62RHR.1001018100	62RHR.1001018100B
12	22	105	12	11,8	22	6	62RHR.1201222105	62RHR.1201222105B
14	26	120	14	13,8	25	7	62RHR.1401426120	62RHR.1401426120B
16	30	150	16	15,8	30	8	62RHR.1601630150	62RHR.1601630150B
18	34	150	18	17,7	30	9	62RHR.1801834150	62RHR.1801834150B
20	38	150	20	19,7	30	10	62RHR.2002038150	62RHR.2002038150B

■ zur Eigenbeschichtung vorgesehen - ohne geeignete Beschichtung nicht einsetzbar.
 ■ provided for own coating. Not suitable without adapted coating.

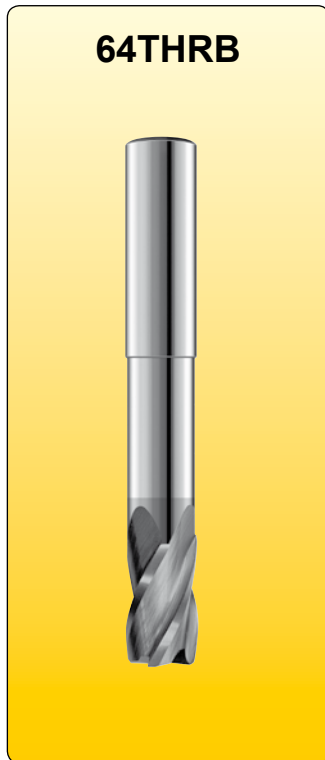
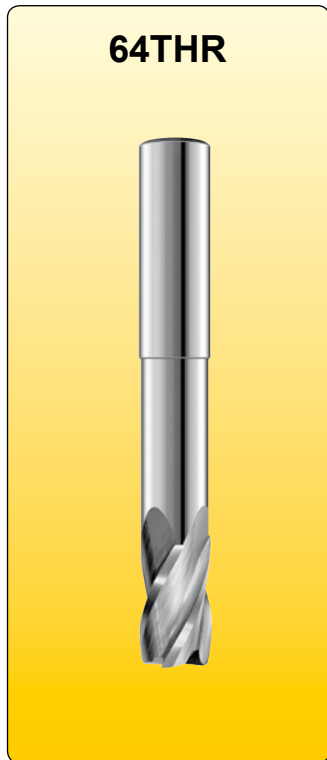
Torusfräser - Z=4 Drall 30° - WN - für gehärtete Stähle
Torus cutters - Z=4 Helix 30° - Internal standard - for hardened steels

Einsatzgebiete / Range of application

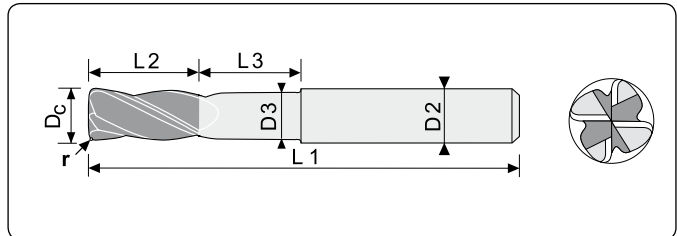
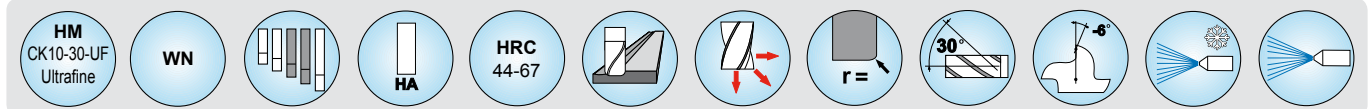
 C:Stahlwerkstoffe / Steels
 C3.2-3.5

**2.
02**

D _c h10	L2	L1	D2 h6	D3	L3	r	64THR	64THRB
							■	Beschichtet / Coated
2	5	50	4	1,9	3	0,4	64THR.020040550	64THR.020040550B
3	6	60	6	2,9	6	0,5	64THR.030060660	64THR.030060660B
4	7	75	6	3,9	7	0,5	64THR.040060775	64THR.040060775B
5	8	75	6	4,9	8	0,5	64THR.050060875	64THR.050060875B
6	12	80	6	5,9	12	0,5	64THR.060061280	64THR.060061280B
8	14	100	8	7,8	15	1	64THR.0800814100	64THR.0800814100B
10	18	100	10	9,8	20	1	64THR.1001018100	64THR.1001018100B
12	22	105	12	11,8	22	1	64THR.1201222105	64THR.1201222105B
14	26	120	14	13,8	25	1,5	64THR.1401426120	64THR.1401426120B
16	30	150	16	15,8	30	1,5	64THR.1601630150	64THR.1601630150B
18	34	150	18	17,7	30	2	64THR.1801834150	64THR.1801834150B
20	38	150	20	19,7	30	2	64THR.2002038150	64THR.2002038150B

■ zur Eigenbeschichtung vorgesehen - ohne geeignete Beschichtung nicht einsetzbar.
 ■ provided for own coating. Not suitable without adapted coating.

Radiusfräser - Z=4 Drall 30° - WN - für gehärtete Stähle
Ball nose cutters - Z=4 Helix 30° - Internal standard - for hardened steels

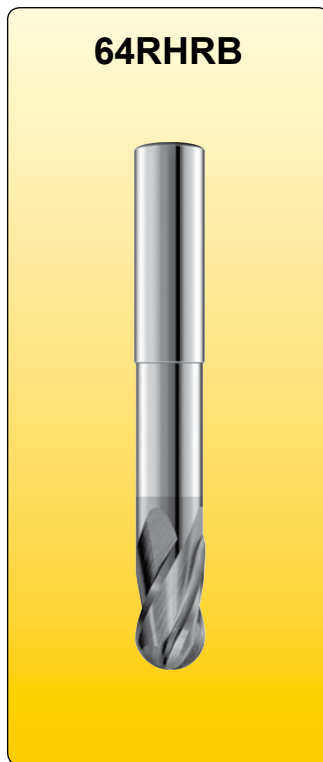
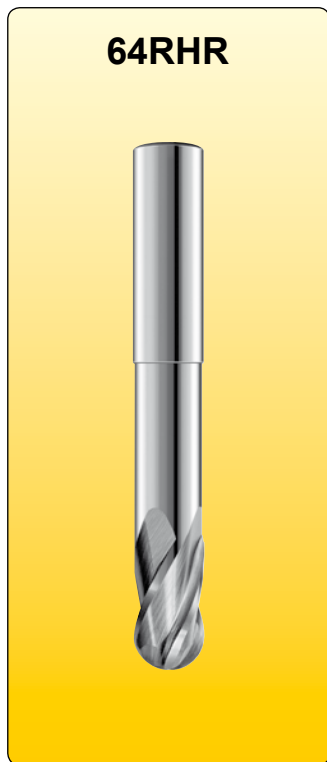
2.
02



Einsatzgebiete / Range of application

C:Stahlwerkstoffe / Steels
C3.2-3.5

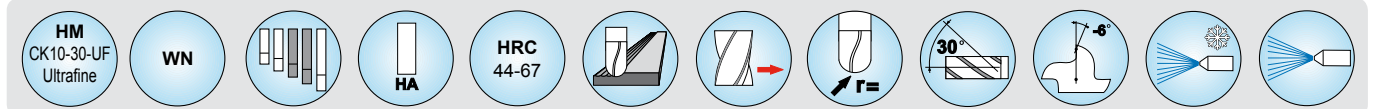
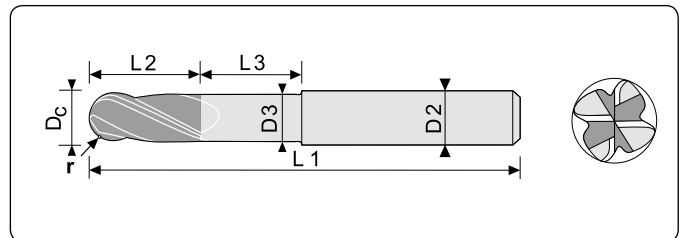

D _c h10	L2	L1	D2 h6	D3	L3	r	64RHR	64RHRB
							■	Beschichtet / Coated
2	5	50	4	1,9	3	1	64RHR.020040550	64RHR.020040550B
3	6	60	6	2,9	6	1,5	64RHR.030060660	64RHR.030060660B
4	7	75	6	3,9	7	2	64RHR.040060775	64RHR.040060775B
5	8	75	6	4,9	8	2,5	64RHR.050060875	64RHR.050060875B
6	12	80	6	5,9	12	3	64RHR.060061280	64RHR.060061280B
8	14	100	8	7,8	15	4	64RHR.0800814100	64RHR.0800814100B
10	18	100	10	9,8	20	5	64RHR.1001018100	64RHR.1001018100B
12	22	105	12	11,8	22	6	64RHR.1201222105	64RHR.1201222105B
14	26	120	14	13,8	25	7	64RHR.1401426120	64RHR.1401426120B
16	30	150	16	15,8	30	8	64RHR.1601630150	64RHR.1601630150B
18	34	150	18	17,7	30	9	64RHR.1801834150	64RHR.1801834150B
20	38	150	20	19,7	30	10	64RHR.2002038150	64RHR.2002038150B

■ zur Eigenbeschichtung vorgesehen - ohne geeignete Beschichtung nicht einsetzbar.
 ■ provided for own coating. Not suitable without adapted coating.

Mehrschneidenfräser - Drall 45° - WN - für gehärtete Stähle
Multiflutes cutters - Helix 45° - Internal standard - for hardened steels

Einsatzgebiete / Range of application

C: Stahlwerkstoffe / Steels
 C3.2-3.5

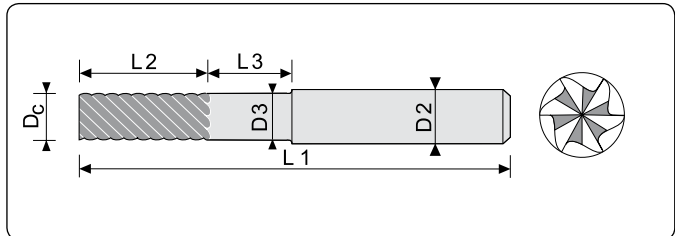
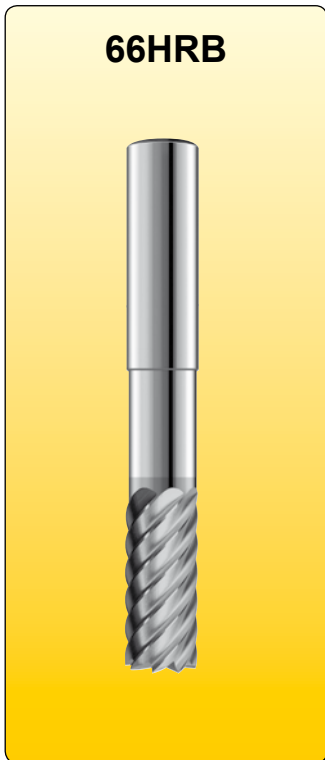
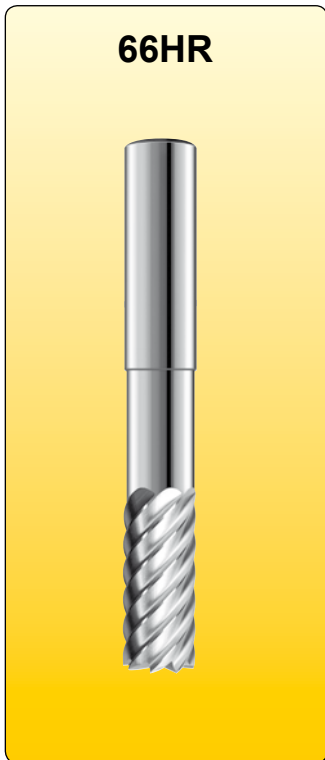

2.
02

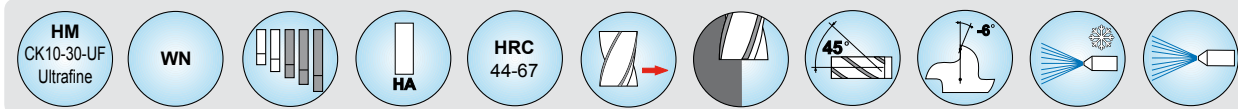

D _c h10	L2	L1	D2 h6	D3	L3	Z	66HR	66HRB
							■	Beschichtet / Coated
4	11	57	6	3,9	8	6	66HR.040061157	66HR.040061157B
5	13	57	6	4,9	8	6	66HR.050061357	66HR.050061357B
6	15	57	6	5,9	12	6	66HR.060061557	66HR.060061557B
6	18	80	6	5,9	18	6	66HR.060061880	66HR.060061880B
8	20	63	8	7,8	12	6	66HR.080082063	66HR.080082063B
8	23	100	8	7,8	23	6	66HR.0800823100	66HR.0800823100B
10	23	72	10	9,8	12	8	66HR.100102372	66HR.100102372B
10	25	100	10	9,8	25	8	66HR.1001025100	66HR.1001025100B
12	28	83	12	11,8	15	8	66HR.120122883	66HR.120122883B
12	30	100	12	11,8	30	8	66HR.1201230100	66HR.1201230100B
14	28	83	14	13,8	15	8	66HR.140142883	66HR.140142883B
14	30	120	14	13,8	30	8	66HR.1401430120	66HR.1401430120B
16	32	92	16	15,8	18	10	66HR.160163292	66HR.160163292B
16	40	150	16	15,8	40	10	66HR.1601640150	66HR.1601640150B
18	35	92	18	17,7	18	10	66HR.180183592	66HR.180183592B
18	45	150	18	17,7	45	10	66HR.1801845150	66HR.1801845150B
20	40	104	20	19,7	20	12	66HR.2002040104	66HR.2002040104B
20	50	150	20	19,7	50	12	66HR.2002050150	66HR.2002050150B

■ zur Eigenbeschichtung vorgesehen - ohne geeignete Beschichtung nicht einsetzbar.
 ■ provided for own coating. Not suitable without adapted coating.

Torus Mehrschneidenfräser - Drall 45° - WN - für gehärtete Stähle
Torus multiflutes cutters - Helix 45° - Internal standard - for hardened steels

2.
02

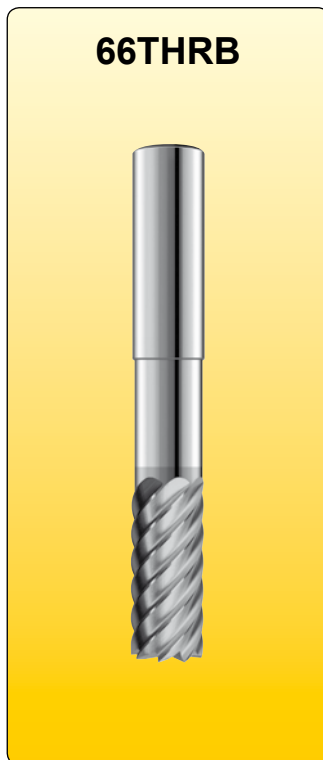
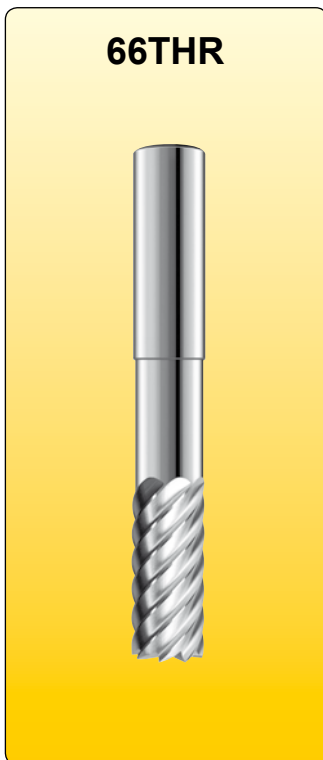

Einsatzgebiete / Range of application

C:Stahlwerkstoffe / Steels
C3.2-3.5

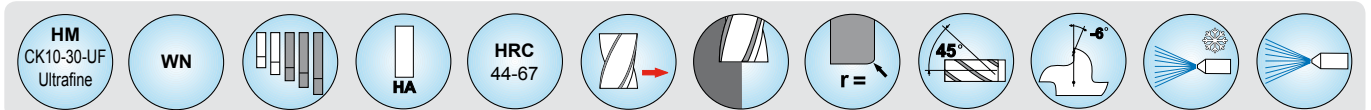
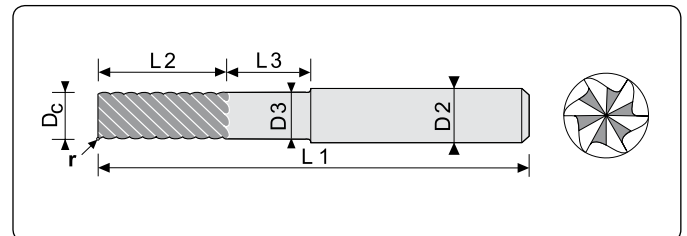

D _c h10	L2	L1	D2 h6	D3	L3	Z	r	66THR	66THRB
								■	Beschichtet / Coated
4	11	57	6	3,9	8	6	0,5	66THR.040061157	66THR.040061157B
5	13	57	6	4,9	8	6	0,5	66THR.050061357	66THR.050061357B
6	15	57	6	5,9	12	6	0,5	66THR.060061557	66THR.060061557B
6	18	80	6	5,9	18	6	0,5	66THR.060061880	66THR.060061880B
8	20	63	8	7,8	12	6	0,5	66THR.080082063	66THR.080082063B
8	23	100	8	7,8	23	6	0,5	66THR.0800823100	66THR.0800823100B
10	23	72	10	9,8	12	8	1	66THR.100102372	66THR.100102372B
10	25	100	10	9,8	25	8	1	66THR.1001025100	66THR.1001025100B
12	28	83	12	11,8	15	8	1	66THR.120122883	66THR.120122883B
12	30	100	12	11,8	30	8	1	66THR.1201230100	66THR.1201230100B
14	28	83	14	13,8	15	8	1	66THR.140142883	66THR.140142883B
14	30	120	14	13,8	30	8	1	66THR.1401430120	66THR.1401430120B
16	32	92	16	15,8	18	10	1	66THR.160163292	66THR.160163292B
16	40	150	16	15,8	40	10	1	66THR.1601640150	66THR.1601640150B
18	35	92	18	17,7	18	10	1,5	66THR.180183592	66THR.180183592B
18	45	150	18	17,7	45	10	1,5	66THR.1801845150	66THR.1801845150B
20	40	104	20	19,7	20	12	1,5	66THR.2002040104	66THR.2002040104B
20	50	150	20	19,7	50	12	1,5	66THR.2002050150	66THR.2002050150B

■ zur Eigenbeschichtung vorgesehen - ohne geeignete Beschichtung nicht einsetzbar.
 ■ provided for own coating. Not suitable without adapted coating.



2.
03

Fräser für Graphitbearbeitung
Milling cutters for graphite

Schnittgeschwindigkeit V_c (m/min) - für die Graphitbearbeitung Cutting speed V_c (m/min) - for graphite machining

Für die Graphitbearbeitung eignen sich Diamantbeschichtete Werkzeuge bestens For graphite machining diamond coated tools are best suited		
Graphitkörnungen (μm) Graphite grain size (μm)		Schnittgeschwindigkeit V_c (m/min) Cutting speed V_c (m/min)
1 - 5	mit Cer-D (Diamant) Beschichtung with Cer-D (Diamond) coating	150 - 250
5 - 10		250 - 350
10 - 15		400 - 450
15 - 20		400 - 600
20 - 25		700 - 800
25 - 30		800 - 1000

Zur Elektrodenfertigung im Fomenbau werden meist Graphite mittlerer Körnung eingesetzt
For the production of electrodes in mould making mainly graphites of medium grains are used

Schnittgeschwindigkeit V_c (m/min) / Cutting speed V_c (m/min)				
Gruppe G: Graphit Group G: Graphite				
	Werkstoffbezeichnung Material description	Festigkeit HV 10 Strength HV 10	VHM CK05-10 MG Carbide CK05-10 MG	Cer-D V_c (m/min)
G 1.1	C-800	230 - 250	■	500 - 600

- Nur zur Selbstbeschichtung bestimmt
- Only assigned for own coating

V_c (m/min)	D_c (mm)									
	2,00	3,00	4,00	5,00	6,00	8,00	10,00	12,00	14,00	16,00
	Δ Drehzahl n (min^{-1}) / Revolution n (min^{-1})									
150	23885	15924	11943	9554	7962	5971	4777	3981	3412	2986
200	31847	21231	15924	12739	10616	7962	6369	5308	4550	3981
250	39809	26539	19904	15924	13270	9952	7962	6635	5687	4976
300	47771	31847	23885	19108	15924	11943	9554	7962	6824	5971
350	55732	37155	27866	22293	18577	13933	11146	9289	7962	6967
400	63694	42463	31847	25478	21231	15924	12739	10616	9099	7962
450	71656	47771	35828	28662	23885	17914	14331	11943	10237	8957
500	79618	53079	39809	31847	26539	19904	15924	13270	11374	9952
550	87580	58386	43790	35032	29193	21895	17516	14597	12511	10947
600	95541	63694	47771	38217	31847	23885	19108	15924	13649	11943
650	103503	69002	51752	41401	34501	25876	20701	17251	14786	12938
700	111465	74310	55732	44586	37155	27866	22293	18577	15924	13933
750	119427	79618	59713	47771	39809	29857	23885	19904	17061	14928
800	127389	84926	63694	50955	42463	31847	25478	21231	18198	15924
900	143312	95541	71656	57325	47771	35828	28662	23885	20473	17914
1000	159236	106157	79618	63694	53079	39809	31847	26539	22748	19904

Δ oder Höchstdrehzahl der Werkzeugmaschine
 Δ a maximum revolution speed of machine tool

Einsatzdaten: f_z (mm) - Fräser für Graphitbearbeitung mit Cer-D (Diamant) Beschichtung
 Cutting data: f_z (mm) - Milling cutters for graphite machining with Cer-D (Diamond) coating

Radius- (Kugel) und Torusfräser
 Ball nose - (Kugel) and Torus cutters

DIN 6527-L - WN kurz = f_z (mm) nach Tabelle
 DIN 6527-L - Internal Standard short = f_z (mm) according to table

WN überlang - extralang = f_z (mm) nach Tabelle x 0,7
 Internal standard - extralong = f_z (mm) according to table x 0,7

2.
03

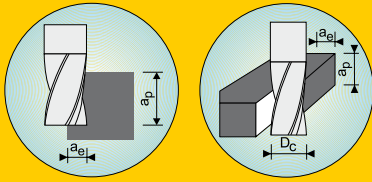
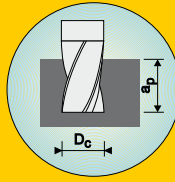
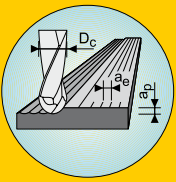
Gruppe G: Graphit C - 800 Group G: Graphite C - 800			
	Eck-/ Konturenfräsen Side-Contour milling	Nutenfräsen Slot milling	Kopierfräsen - Zeilenfräsen Copying mills - Z levelling
			
	$a_p = 0,5 \times D_c$ $a_e = 0,5 \times D_c$	$a_p = 0,5 \times D_c$ $a_e = 1,0 \times D_c$	$a_p = 0,2 \times D_c$ $a_e = 0,2 \times D_c$
D_c (mm)	f_z (mm)	f_z (mm)	f_z (mm)
2,00	0,022	0,017	0,024
2,50	0,028	0,021	0,030
3,00	0,033	0,026	0,036
4,00	0,044	0,034	0,048
5,00	0,055	0,043	0,060
6,00	0,066	0,051	0,072
8,00	0,088	0,068	0,096
10,00	0,110	0,085	0,120
12,00	0,132	0,102	0,144
14,00	0,154	0,119	0,168
16,00	0,176	0,136	0,192
18,00	0,198	0,153	0,216
20,00	0,220	0,170	0,240

Einsatzdaten: f (mm) - Kreuzverzahnt - mit Cer-D Beschichtung

Schaft und Radiusfräser - mit spezial Kreuzverzahnungen (F/M) - mit Feinverzahnung und Spanteiler (66GF-D)

Cutting data: f (mm) - Cross cut - with Cer-D coating

End mills and ball nose cutters - with special cross cut (F/M) - with fine cut and chip breaker (66GF-D)

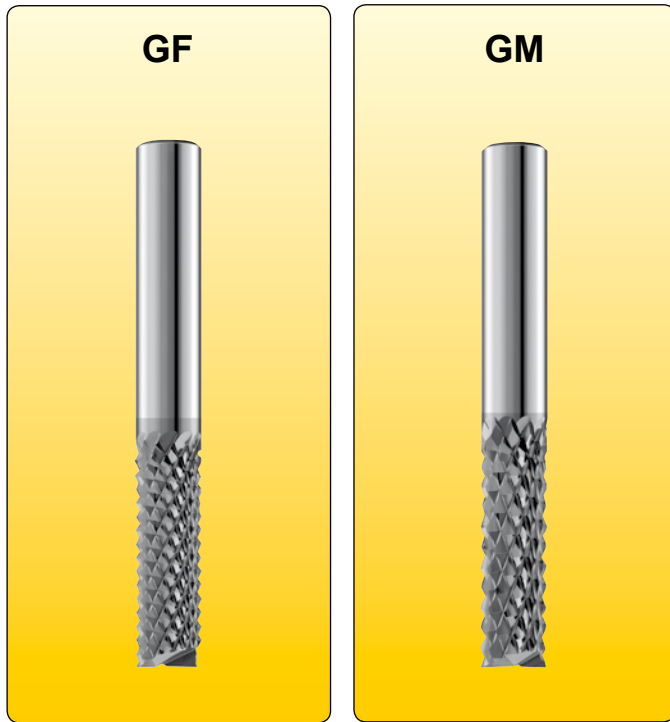
**2.
03**
Gruppe G: Graphit C - 800
Gruppe G: Graphit C - 800

D _c (mm)	Schruppen <i>Roughing</i>		Schlichten <i>Finishing</i>		Verzahnung <i>Cut type</i>	Verzahnung <i>Cut type</i>
	Verzahnung <i>Cut type</i>		Verzahnung <i>Cut type</i>			
	GF	GM	GF	GM	GF	GF
	Eck-/ Konturenfräsen <i>Side-Contour milling</i>		Nutenfräsen <i>Slot milling</i>		Eck-/ Konturenfräsen <i>Side-Contour milling</i>	Kopierfräsen <i>Copy milling</i>
	a _p = 0,5 x D _c a _e = 0,5 x D _c		a _p = 0,5 x D _c		a _p = 0,5 x D _c a _e = 0,3 x D _c	a _p = 0,02 x D _c a _e = 0,03 x D _c
mit Cer-D (Diamant) Beschichtung / with Cer-D (Diamond) coating						
	f (mm)	f (mm)	f (mm)	f (mm)	f (mm)	f (mm)
2,00	0,12	0,12	0,10	0,10	0,10	0,10
2,50	0,12	0,12	0,10	0,10	0,10	0,10
3,00	0,16	0,16	0,14	0,12	0,14	0,12
3,50	0,16	0,16	0,14	0,12	0,16	0,14
4,00	0,22	0,18	0,20	0,16	0,20	0,15
5,00	0,25	0,22	0,22	0,18	0,22	0,16
6,00	0,30	0,26	0,26	0,22	0,26	0,18
7,00	0,30	0,26	0,26	0,22	0,28	0,20
8,00	0,35	0,35	0,30	0,26	0,30	0,24
9,00	0,35	0,35	0,30	0,26	0,32	0,30
10,00	0,50	0,40	0,36	0,30	0,36	0,32
11,00	0,50	0,40	0,36	0,30	0,38	0,34
12,00	0,60	0,50	0,40	0,35	0,40	0,36
14,00	0,65	0,55	0,45	0,42	0,45	0,40
16,00	0,70	0,60	0,50	0,50	0,50	0,45
18,00	0,80	0,70	0,55	0,55	0,55	0,50
20,00	1,00	0,85	0,60	0,60	0,60	0,56

Torus Graphitfräser - Z=2 Drall 30° - WN

Torus cutters for graphite - Z=2 Helix 30° - Internal standard

2.
03

72GT



72GTD



Einsatzgebiete / Range of application

G: Graphit / Graphite
G1.1

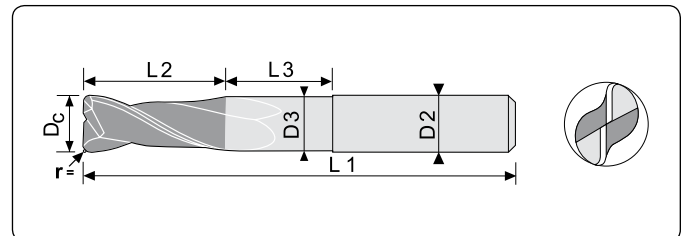

D _c h10	L2	L1	D2 h6	D3	L3	r	72GT	72GTD
							■	Beschichtet / Coated
2	6	50	3	1,9	6	0,5	72GT.020030650	72GT.020030650D
2	10	100	3	1,9	10	0,5	72GT.0200310100	72GT.0200310100D
3	8	60	3	2,9	8	0,5	72GT.030030860	72GT.030030860D
3	12	100	3	2,9	12	0,5	72GT.0300312100	72GT.0300312100D
4	10	60	4	3,8	10	0,5	72GT.040041060	72GT.040041060D
4	15	100	4	3,8	15	0,5	72GT.0400415100	72GT.0400415100D
5	12	60	5	4,8	12	0,5	72GT.050051260	72GT.050051260D
5	15	100	5	4,8	15	0,5	72GT.0500515100	72GT.0500515100D
6	20	75	6	5,8	20	0,5	72GT.060062075	72GT.060062075D
6	25	100	6	5,8	25	0,5	72GT.0600625100	72GT.0600625100D
6	30	150	6	5,8	30	0,5	72GT.0600630150	72GT.0600630150D
8	20	75	8	7,8	20	1	72GT.080082075	72GT.080082075D
8	25	100	8	7,8	25	1	72GT.0800825100	72GT.0800825100D
8	30	150	8	7,8	30	1	72GT.0800830150	72GT.0800830150D
10	25	100	10	9,8	25	1	72GT.1001025100	72GT.1001025100D
10	30	150	10	9,8	30	1	72GT.1001030150	72GT.1001030150D
12	25	100	12	11,8	25	1	72GT.1201225100	72GT.1201225100D
12	40	150	12	11,8	40	1	72GT.1201240150	72GT.1201240150D
16	25	100	16	15,8	25	1,5	72GT.1601625100	72GT.1601625100D
16	40	150	16	15,8	40	1,5	72GT.1601640150	72GT.1601640150D

■ zur Eigenbeschichtung vorgesehen und sind ohne geeignete Beschichtung nicht einsetzbar.

■ Provided for own coating only and not applicable without adapted coating.

Radius Graphitfräser - Z=2 Drall 30° - WN

Ball nose cutters for graphite - Z=2 Helix 30° - Internal standard

Einsatzgebiete / Range of application

G: Graphit / Graphite
G1.1

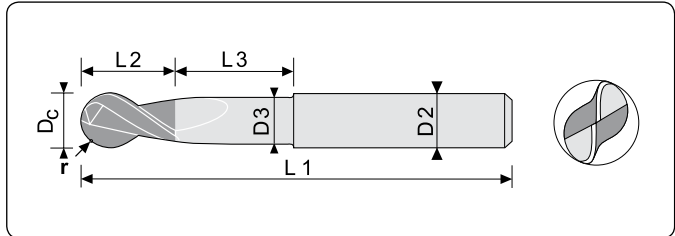
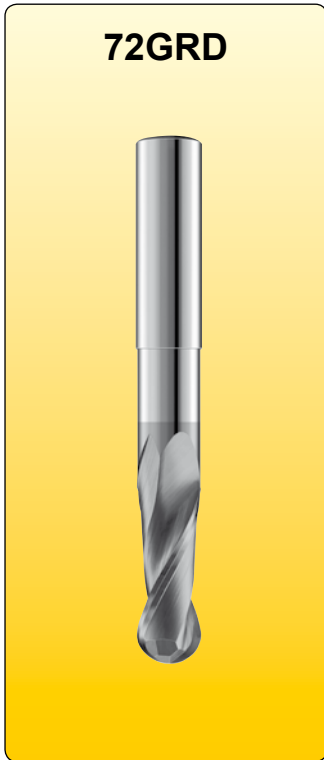

2.
03



D _c h10	L2	L1	D2 h6	D3	L3	r	72GR	72GRD
							■	Beschichtet / Coated
2	6	50	3	1,9	6	1	72GR.020030650	72GR.020030650D
2	10	100	3	1,9	10	1	72GR.0200310100	72GR.0200310100D
3	8	60	3	2,9	8	1,5	72GR.030030860	72GR.030030860D
3	12	100	3	2,9	12	1,5	72GR.0300312100	72GR.0300312100D
4	10	60	4	3,8	10	2	72GR.040041060	72GR.040041060D
4	15	100	4	3,8	15	2	72GR.0400415100	72GR.0400415100D
5	12	60	5	4,8	12	2,5	72GR.050051260	72GR.050051260D
5	15	100	5	4,8	15	2,5	72GR.0500515100	72GR.0500515100D
6	20	75	6	5,8	20	3	72GR.060062075	72GR.060062075D
6	25	100	6	5,8	25	3	72GR.0600625100	72GR.0600625100D
6	30	150	6	5,8	30	3	72GR.0600630150	72GR.0600630150D
8	20	75	8	7,8	20	4	72GR.080082075	72GR.080082075D
8	25	100	8	7,8	25	4	72GR.0800825100	72GR.0800825100D
8	30	150	8	7,8	30	4	72GR.0800830150	72GR.0800830150D
10	25	100	10	9,8	25	5	72GR.1001025100	72GR.1001025100D
10	30	150	10	9,8	30	5	72GR.1001030150	72GR.1001030150D
12	25	100	12	11,8	25	6	72GR.1201225100	72GR.1201225100D
12	40	150	12	11,8	40	6	72GR.1201240150	72GR.1201240150D
16	25	100	16	15,8	25	8	72GR.1601625100	72GR.1601625100D
16	40	150	16	15,8	40	8	72GR.1601640150	72GR.1601640150D

■ zur Eigenbeschichtung vorgesehen und sind ohne geeignete Beschichtung nicht einsetzbar.
 ■ Provided for own coating only and not applicable without adapted coating.

Radius Graphitfräser - Z=3 Drall 30° Ungleiche Schneidenteilung - WN Radius cutters for graphite - Z=3 Helix 30° univen indexing - Internal Standard

2.
03

73GRI



73GRID



Einsatzgebiete / Range of application

G: Graphit / Graphite
G1.1

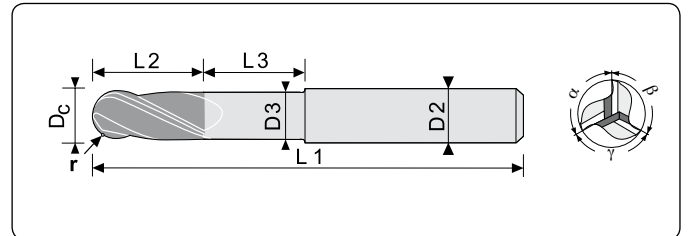

D _c h10	L2	L1	D2 h6	D3	L3	r	73GRI	73GRID
							■	Beschichtet / Coated
2	6	50	3	1,9	6	1	73GRI.020030650	73GRI.020030650D
3	8	60	3	2,9	8	1,5	73GRI.030030860	73GRI.030030860D
4	10	60	4	3,8	10	2	73GRI.040041060	73GRI.040041060D
5	12	60	5	4,8	12	2,5	73GRI.050051260	73GRI.050051260D
6	20	75	6	5,8	20	3	73GRI.060062075	73GRI.060062075D
8	20	75	8	7,8	20	4	73GRI.080082075	73GRI.080082075D
10	25	100	10	9,8	25	5	73GRI.1001025100	73GRI.1001025100D
12	25	100	12	11,8	25	6	73GRI.1201225100	73GRI.1201225100D
16	25	100	16	15,8	25	8	73GRI.1601625100	73GRI.1601625100D

■ zur Eigenbeschichtung vorgesehen und sind ohne geeignete Beschichtung nicht einsetzbar.
 ■ Provided for own coating only and not applicable without adapted coating.

Torus Graphitfräser - Z=3 Drall 30° Ungleiche Schneidenteilung - WN
Torus cutters for graphite - Z=3 Helix 30° univen indexing - Internal Standard

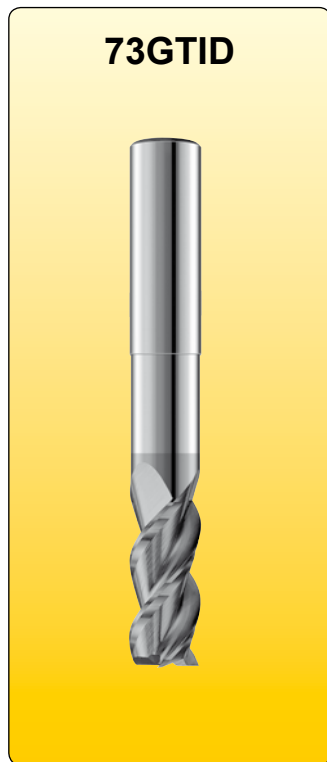
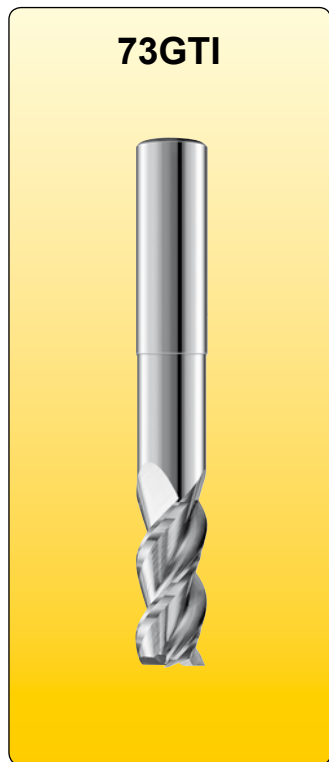

Einsatzgebiete / Range of application

G: Graphit / Graphite
 G1.1

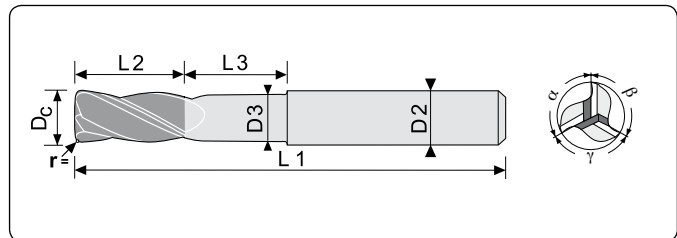

**2.
03**

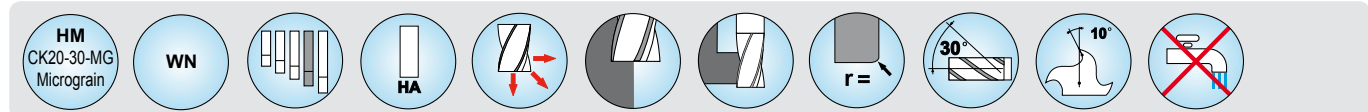

D _c h10	L2	L1	D2 h6	D3	L3	r	73GTI	73GTID
							■	Beschichtet / Coated
2	6	50	3	1,9	6	0,5	73GTI.020030650	73GTI.020030650D
3	8	60	3	2,9	8	0,5	73GTI.030030860	73GTI.030030860D
4	10	60	4	3,8	10	0,5	73GTI.040041060	73GTI.040041060D
5	12	60	5	4,8	12	0,5	73GTI.050051260	73GTI.050051260D
6	20	75	6	5,8	20	0,5	73GTI.060062075	73GTI.060062075D
8	20	75	8	7,8	20	1	73GTI.080082075	73GTI.080082075D
10	25	100	10	9,8	25	1	73GTI.1001025100	73GTI.1001025100D
12	25	100	12	11,8	25	1	73GTI.1201225100	73GTI.1201225100D
16	25	100	16	15,8	25	1,5	73GTI.1601625100	73GTI.1601625100D

■ zur Eigenbeschichtung vorgesehen und sind ohne geeignete Beschichtung nicht einsetzbar.
 ■ Provided for own coating only and not applicable without adapted coating.

Graphit Nutenfräser - spezial Kreuzverzahnung - WN Slot milling cutters for graphite - special cross cut - Internal Standard

2.
03

108GFD





108GMD

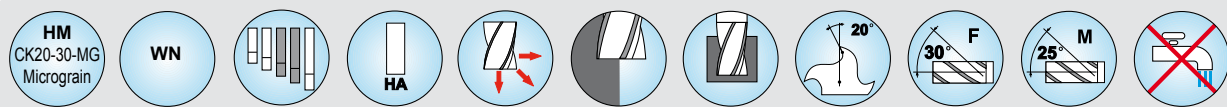
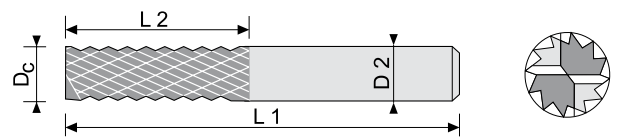

Einsatzgebiete / Range of application

G: Graphit / Graphite
G1.1



D _c h10	L2	L1	D2 h6	108GFD	108GMD
				Beschichtet / Coated	Beschichtet / Coated
2	7	40	2	108GF.020020740D	108GM.020020740D
2	7	50	6	108GF.020060750D	108GM.020060750D
3	10	40	3	108GF.030031040D	108GM.030031040D
3	12	50	6	108GF.030061250D	108GM.030061250D
4	15	40	4	108GF.040041540D	108GM.040041540D
4	20	50	6	108GF.040062050D	108GM.040062050D
5	16	50	5	108GF.050051650D	108GM.050051650D
5	25	75	6	108GF.050062575D	108GM.050062575D
6	18	50	6	108GF.060061850D	108GM.060061850D
6	35	75	6	108GF.060063575D	108GM.060063575D
8	25	63	8	108GF.080082563D	108GM.080082563D
8	40	100	8	108GF.0800840100D	108GM.0800840100D
10	30	72	10	108GF.100103072D	108GM.100103072D
12	32	83	12	108GF.120123283D	108GM.120123283D
16	36	92	16	108GF.160163692D	108GM.160163692D
20	45	104	20	108GF.2002045104D	108GM.2002045104D
Verzahnung - Typ Cut type				F fein F fine 	M mittel M medium 

- unbeschichtete Ausführung auf Anfrage
- uncoated version upon request

Graphit Bohrfräser - spezial Kreuzverzahnung - WN
Drill milling cutters for graphite - special cross cut - Internal Standard

Einsatzgebiete / Range of application

G: Graphit / Graphite
 G1.1

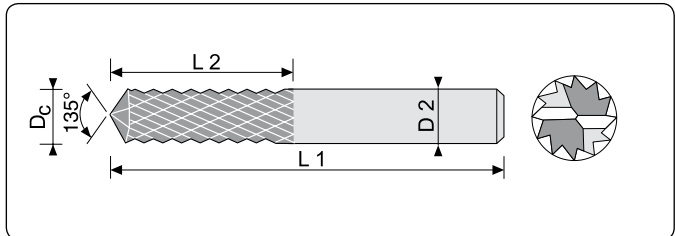
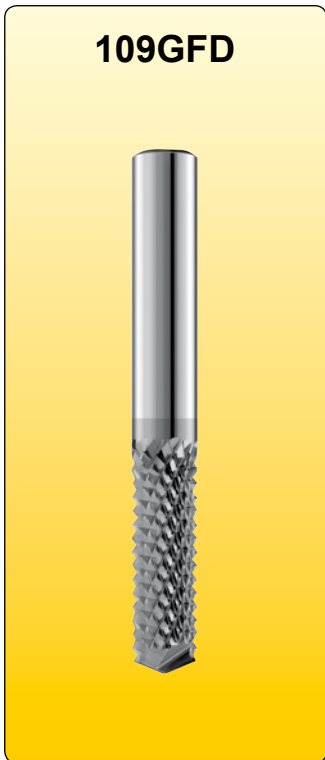

2.
03

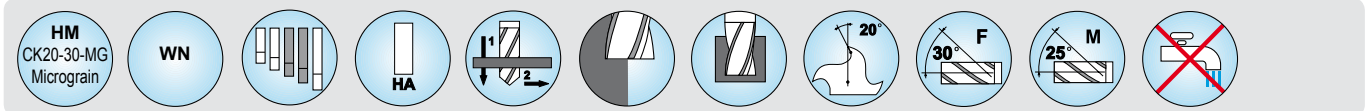

D _c h10	L2	L1	D2 h6	α	109GFD	109GMD
					■	Beschichtet / Coated
2	7	40	2	135	109GF.020020740D	109GM.020020740D
2	7	50	6	135	109GF.020060750D	109GM.020060750D
3	10	40	3	135	109GF.030031040D	109GM.030031040D
3	12	50	6	135	109GF.030061250D	109GM.030061250D
4	15	40	4	135	109GF.040041540D	109GM.040041540D
4	20	50	6	135	109GF.040062050D	109GM.040062050D
5	16	50	5	135	109GF.050051650D	109GM.050051650D
5	25	75	6	135	109GF.050062575D	109GM.050062575D
6	18	50	6	135	109GF.060061850D	109GM.060061850D
6	35	75	6	135	109GF.060063575D	109GM.060063575D
8	25	63	8	135	109GF.080082563D	109GM.080082563D
8	40	100	8	135	109GF.0800840100D	109GM.0800840100D
10	30	72	10	135	109GF.100103072D	109GM.100103072D
12	32	83	12	135	109GF.120123283D	109GM.120123283D
16	36	92	16	135	109GF.160163692D	109GM.160163692D
20	45	104	20	135	109GF.2002045104D	109GM.2002045104D
Verzahnung - Typ <i>Cut type</i>					F fein <i>F fine</i>	M mittel <i>M medium</i>

■ unbeschichtete Ausführung auf Anfrage
 ■ uncoated version upon request

Graphit - Radiusfräser - kreuzverzahnt - WN
Ball nose cutters for graphite - cross cut - Internal Standard

2.
03

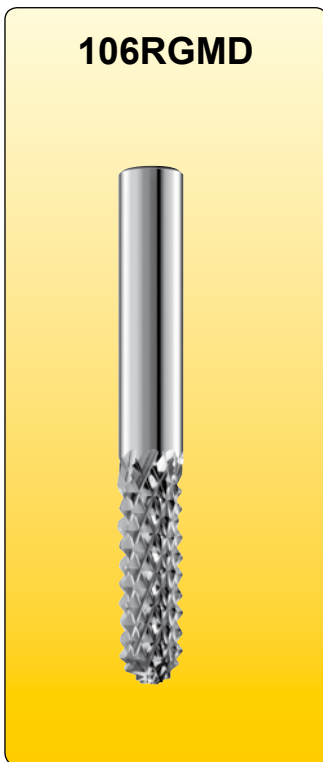
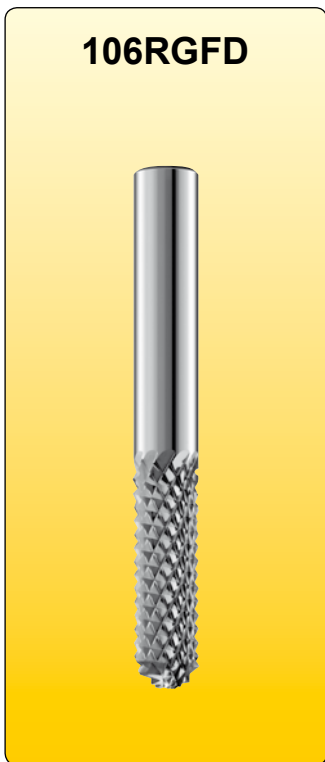

Einsatzgebiete / Range of application

G: Graphit / Graphite
G1.1

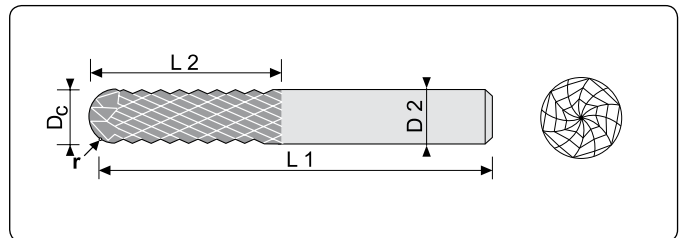

D _c h10	L2	L1	D2 h6	r	106RGFD	106RGMD
					■	Beschichtet / Coated
3	10	40	3	1,5	106RGF.030031040D	106RGM.030031040D
3	12	50	6	1,5	106RGF.030061250D	106RGM.030061250D
4	15	40	4	2	106RGF.040041540D	106RGM.040041540D
4	20	50	6	2	106RGF.040062050D	106RGM.040062050D
5	16	50	5	2,5	106RGF.050051650D	106RGM.050051650D
5	25	75	6	2,5	106RGF.050062575D	106RGM.050062575D
6	18	50	6	3	106RGF.060061850D	106RGM.060061850D
6	35	75	6	3	106RGF.060063575D	106RGM.060063575D
8	25	63	8	4	106RGF.080082563D	106RGM.080082563D
8	40	100	8	4	106RGF.0800840100D	106RGM.0800840100D
10	30	72	10	5	106RGF.100103072D	106RGM.100103072D
12	32	83	12	6	106RGF.120123283D	106RGM.120123283D
16	36	92	16	8	106RGF.160163692D	106RGM.160163692D
20	45	104	20	10	106RGF.2002045104D	106RGM.2002045104D

Verzahnung - Typ
Cut type

F fein
F fine

M mittel
M medium



■ unbeschichtete Ausführung auf Anfrage
■ uncoated version upon request

Graphit - Schafffräser - engverzahnt - mit Spanteiler - WN
End mills for graphite - fine cut with chip breaker - Internal Standard

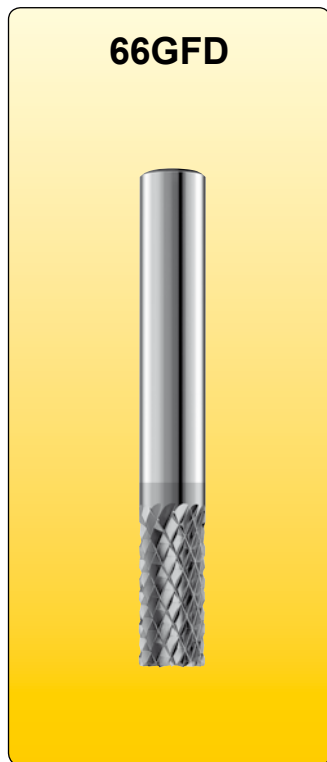
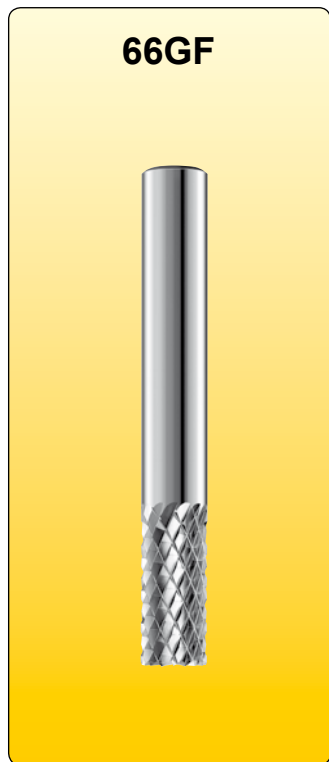

Einsatzgebiete / Range of application

G: Graphit / Graphite
 G1.1

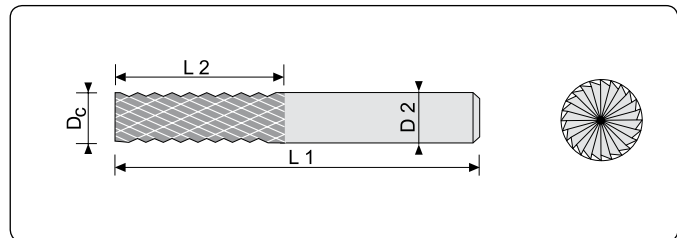

**2.
03**

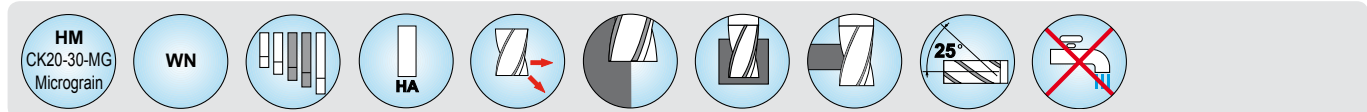

D _c h10	L2	L1	D2 h6	66GF	66GFD
				□	Beschichtet / Coated
3	10	40	3	66GF.030031040	66GF.030031040D
3,5	10	40	3,5	66GF.035351040	66GF.035351040D
4	11	40	4	66GF.040041140	66GF.040041140D
4,5	11	50	4,5	66GF.045451150	66GF.045451150D
5	13	50	5	66GF.050051350	66GF.050051350D
6	16	50	6	66GF.060061650	66GF.060061650D
7	16	60	7	66GF.070071660	66GF.070071660D
8	19	63	8	66GF.080081963	66GF.080081963D
9	19	63	9	66GF.090091963	66GF.090091963D
10	22	72	10	66GF.100102272	66GF.100102272D
11	22	72	11	66GF.110112272	66GF.110112272D
12	26	83	12	66GF.120122683	66GF.120122683D
14	26	83	14	66GF.140142683	66GF.140142683D
16	32	92	16	66GF.160163292	66GF.160163292D
18	32	92	18	66GF.180183292	66GF.180183292D
20	38	104	20	66GF.2002038104	66GF.2002038104D

□ zur Eigenbeschichtung vorgesehen und sind ohne geeignete Beschichtung nicht einsetzbar.
 □ Provided for own coating only and not applicable without adapted coating.

Graphit Radiusfräser - engverzahnt mit Spanteiler - WN
Ball nose end mills for graphite - fine cut with chip breaker - Internal Standard

2.
03

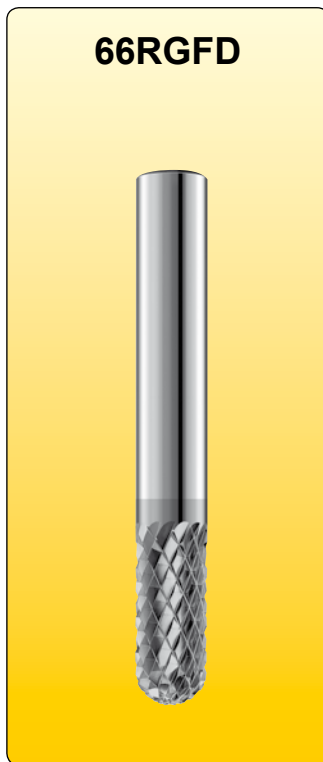

Einsatzgebiete / Range of application

G: Graphit / Graphite
G1.1

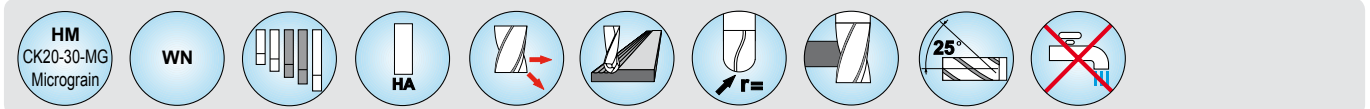
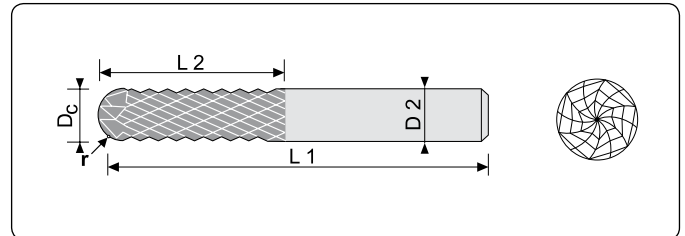

D _c h10	L2	L1	D2 h6	r	66RGF	66RGFD
					■	Beschichtet / Coated
3	10	40	3	1,5	66RGF.030031040	66RGF.030031040D
3,5	10	40	3,5	1,75	66RGF.035351040	66RGF.035351040D
4	11	40	4	2	66RGF.040041140	66RGF.040041140D
4,5	11	50	4,5	2,25	66RGF.045451150	66RGF.045451150D
5	13	50	5	2,5	66RGF.050051350	66RGF.050051350D
6	16	50	6	3	66RGF.060061650	66RGF.060061650D
7	16	60	7	3,5	66RGF.070071660	66RGF.070071660D
8	19	63	8	4	66RGF.080081963	66RGF.080081963D
9	19	63	9	4,5	66RGF.090091963	66RGF.090091963D
10	22	72	10	5	66RGF.100102272	66RGF.100102272D
11	22	72	11	5,5	66RGF.110112272	66RGF.110112272D
12	26	83	12	6	66RGF.120122683	66RGF.120122683D
14	26	83	14	7	66RGF.140142683	66RGF.140142683D
16	32	92	16	8	66RGF.160163292	66RGF.160163292D
18	32	92	18	9	66RGF.180183292	66RGF.180183292D
20	38	104	20	10	66RGF.2002038104	66RGF.2002038104D

■ zur Eigenbeschichtung vorgesehen und sind ohne geeignete Beschichtung nicht einsetzbar.
 ■ Provided for own coating only and not applicable without adapted coating.



2.
04

Fräswerkzeuge für Kunststoffe
End mills for composite materials

Übersicht von gebräuchlichen Kunststoffen Summary of common composite materials in use

Duroplaste - kurzspanig Thermosets - short chipping	
Werkstoff - Gruppe B 1.1 Material - Group B 1.1	Festigkeit N/mm ² Strength N/mm ²
Albanit	110
Bakelit	110
Ferrozell	110
Harnstoff-Formaldehyd	80
Melamin-Formaldehyd	80
MF	80
Pertinax	110
Phenol-Formaldehyd	80
Resopal	80
UP	80

Thermoplaste - langspanig Thermoplastics - long chipping	
Werkstoff - Gruppe B 1.2 Material - Group B 1.2	Festigkeit N/mm ² Strength N/mm ²
ABS	35-50
ABC Copolymere	80
Bayolan	70-75
Dogalan	80
Dolin	50-70
Durethan 43	
Fluon	20-40
Hostafion TF	20-40
Hostaform	50-70
Hostalen	20-80
Hostalen PP	20-38
Hostalit	35-60
Hostyren N	40-65
HostyrenS	22-50
Lupolen	20-30/80
Luran	78
Lustran	80
Makralon 80	
Makrolon 5	
Novodur	35-56
Novolen	21-38
PA 6	43/57/80
PA 66	43/57/80
PC	5
PE-HD	20-30
Plexiglas	70-76
PMMA	70-78
Polyamid 43/57/80	
Polyamid 66	43/57/80
Polykarbonate	5
Polyethylen	20-30/80

Thermoplaste - langspanig Thermoplastics - long chipping	
Werkstoff - Gruppe B 1.2 Material - Group B 1.2	Festigkeit N/mm ² Strength N/mm ²
Fortsetzung <i>To be continued</i>	
Polymethylmethacrylat	70-76
Polyoxymethylen	50/70/80
Polypropylen	21-37
Polystrol	80
Polystyrol	2-/50/40-65
Polytetrafluorethylen	20-40
Polyvinylchlorid	32-60
PO M	50/70/80
PP	21-37
PS	40-65
PTFE	20-40
PVC-U	35-60
Resanit	70-76
Risitex	80
Rilsan	40/57/80
S/B	22-50
SAN	78
Solvic	35-60
Styrol Acrylnitril	78
Styrol Buladien	22-50
Teflon	20-40
Trogamid T	48/57/80
Ultraform 50/70/80	
Vestamid 43/57/80	
Vestolen	20-30/80
Vestolen P	21-37
Vestyron	22-50/80
Vostyron	40-50
Vinol	35-60
Vinoflex	35-60

Faserverstärkte Kunststoffe Reinforced plastic fibres	
Werkstoff - Gruppe B 1.4 Material - Group B 1.4	Festigkeit N/mm ² Strength N/mm ²
AFK - Aramidfaser / Aramid fiber	800-1000
	1000-1500
CFK - Kohlefaser / Carbon fiber	800-1000
	1000-1500
GFK - Glasfaser / Fiberglass	800-1000
	1000-1500

Einsatzdaten: f_z (mm) - zur Bearbeitung von Thermoplasten und faserverstärkten Kunststoffen
 Cutting date: f_z (mm) - for machining of thermoplastics and reinforced plastic fibres

Kopierfräser Typ W - Schafffräser Typ W - Schafffräser Typ W mit Spanteiler
 "W" design - Copy milling cutters - "W" design End mills - "W" design End mills with chip breaker

Gruppe B: Kunststoffe - Thermoplaste - Polycarbonate - NE Metalle - Hartgummi Group B: Plastics - Thermoplastics - Polycarbonate - Nonferrous metals - Hard rubber					
B 1.2 B 1.3 B 2.2 B 2.3	Schafffräser - Typ W - mit und ohne Spanteiler "W" design - End mills with and without chip breaker			Torus- Radiusfräser - Typ W Torus - Ball nose milling cutters - W design	
	Eck-/ Konturenfräsen Side-Contour milling		Nutenfräsen Slot milling	Kopierfräsen - Zeilenfräsen Copying mills - Z levelling	
	Schruppen Roughing	Schlichten Finishing		Schruppen Roughing	Schlichten Finishing-
	$a_p = 1,5 \times D_c$ $a_e = 0,8 \times D_c$	$a_p = 1,0 \times D_c$ $a_e = 0,10 \times D_c$	$a_p = 1,0 \times D_c$	$a_p = 0,5 \times D_c$ $a_e = 0,5 \times D_c$	$a_p = 0,05 \times D_c$ $a_e = 0,02 \times D_c$
D_c (mm)	f_z (mm)	f_z (mm)	f_z (mm)	f_z (mm)	f_z (mm)
2,00	0,024	0,022	0,017	0,037	0,030
3,00	0,036	0,033	0,026	0,056	0,045
4,00	0,048	0,044	0,034	0,074	0,060
5,00	0,060	0,055	0,043	0,093	0,075
6,00	0,072	0,066	0,051	0,111	0,090
8,00	0,096	0,088	0,068	0,148	0,120
10,00	0,120	0,110	0,085	0,185	0,150
12,00	0,144	0,132	0,102	0,222	0,180
14,00	0,168	0,154	0,119	0,259	0,210
16,00	0,192	0,176	0,136	0,296	0,240
18,00	0,216	0,198	0,153	0,333	0,270
20,00	0,240	0,220	0,170	0,370	0,300

 2.
04

Gruppe B: faserverstärkte Kunststoffe - AFK - CFK - GFK Group B: reinforced plastic fibres - AFK - CFK - GFK					
B 1.4	Schafffräser mit Spanteiler End mills with chip breaker				
	Eck-/ Konturenfräsen Side-Contour milling		Nutenfräsen Slot milling		
	Schruppen Roughing	Schlichten Finishing			
	$a_p = 1,0 \times D_c$ $a_e = 0,10 \times D_c$	$a_p = 0,75 \times D_c$ $a_e = 0,03 \times D_c$	$a_p = 0,3 \times D_c$		
D_c (mm)	f_z (mm)	f_z (mm)	f_z (mm)		
2,00	0,026	0,024	0,020		
3,00	0,039	0,036	0,030		
4,00	0,052	0,048	0,040		
5,00	0,065	0,060	0,050		
6,00	0,078	0,072	0,060		
8,00	0,104	0,096	0,080		
10,00	0,130	0,120	0,100		
12,00	0,156	0,144	0,120		
14,00	0,182	0,168	0,140		
16,00	0,208	0,192	0,160		
18,00	0,234	0,216	0,180		
20,00	0,260	0,240	0,200		

Einsatzdaten: f (mm) - Schafffräser - kreuzverzahnt für Kunststoffe
Cutting data: f (mm) - Cross cut end mills for composite materials

Schafffräser kreuzverzahnt - mit und ohne Spannuten
Cross cut end mills - with and without chip flute

Gruppe B: Kunststoffe - Thermo- und Duroplaste - Polycarbonate - NE Werkstoffe Group B: Plastics - Thermoplastics - Thermosets - Polycarbonate - Nonferrous materials						
■ B 1.1 ■ B 2.1 ■ B 2.4 ■ B 1.2 ■ B 1.3 ■ B 1.5 ■ B 2.2 ■ B 2.3	■ Duroplaste ■ Thermosets			■ Thermoplaste ■ Thermoplastics		
	Eckfräsen Besäumen - Nutenfräsen Side milling - Contouring - Slot milling			Eckfräsen Besäumen - Nutenfräsen Side milling - Contouring - Slot milling		
	$a_p = 0,8 \times D_c$ $a_e = 1,0 \times D_c$	$a_p = 0,8 \times D_c$ $a_e = 1,0 \times D_c$	$a_p = 1,0 \times D_c$ $a_e = 1,0 \times D_c$	$a_p = 0,8 \times D_c$ $a_e = 1,0 \times D_c$	$a_p = 0,8 \times D_c$ $a_e = 1,0 \times D_c$	$a_p = 1,0 \times D_c$ $a_e = 1,0 \times D_c$
	Verzahnung / Cut type			Verzahnung / Cut type		
	fein - F fine - F	mittel - M medium - M	grob - G course - G	fein - F fine - F	mittel - M medium - M	grob - G course - G
D_c (mm)	f_z (mm)	f_z (mm)	f_z (mm)	f_z (mm)	f_z (mm)	f_z (mm)
2,00	0,20	0,14	0,12	0,16	0,13	0,10
3,00	0,30	0,21	0,18	0,24	0,20	0,15
4,00	0,40	0,28	0,24	0,32	0,26	0,20
5,00	0,50	0,35	0,30	0,40	0,33	0,25
6,00	0,60	0,42	0,36	0,48	0,39	0,30
8,00	0,80	0,56	0,48	0,64	0,52	0,40
10,00	1,00	0,70	0,60	0,80	0,65	0,50
12,00	1,20	0,84	0,72	0,96	0,78	0,60
16,00	1,60	1,12	0,96	1,28	1,04	0,80
20,00	2,00	1,40	1,20	1,60	1,30	1,00

2.
04

Gruppe B: faserverstärkte Kunststoffe - AFK - CFK - GFK Group B: Reinforced plastic fibres - AFK - CFK - GFK						
B 1.4	Schafffräser Kreuzverzahnt - mit CerKo Beschichtung Cross cut end mills - with CerKo coating					
	Eck- und Konturenfräsen - Besäumen Side and contouring milling			Nutenfräsen Slot milling		
	$a_p = 1,0 \times D_c$ $a_e = 0,05 \times D_c$	$a_p = 1,0 \times D_c$ $a_e = 0,05 \times D_c$	$a_p = 1,0 \times D_c$ $a_e = 0,05 \times D_c$	$a_p = 0,35 \times D_c$	$a_p = 0,35 \times D_c$	$a_p = 0,35 \times D_c$
	Verzahnung / Cut type			Verzahnung / Cut type		
	fein - F fine - F	mittel - M medium - M	grob - G course - G	fein - F fine - F	mittel - M medium - M	grob - G course - G
D_c (mm)	f_z (mm)	f_z (mm)	f_z (mm)	f_z (mm)	f_z (mm)	f_z (mm)
2,00	0,16	0,14	0,12	0,14	0,12	0,10
3,00	0,24	0,21	0,18	0,21	0,18	0,15
4,00	0,32	0,28	0,24	0,28	0,24	0,20
5,00	0,40	0,35	0,30	0,35	0,30	0,25
6,00	0,48	0,42	0,36	0,42	0,36	0,30
8,00	0,64	0,56	0,48	0,56	0,48	0,40
10,00	0,80	0,70	0,60	0,70	0,60	0,50
12,00	0,96	0,84	0,72	0,84	0,72	0,60
16,00	1,28	1,12	0,96	1,12	0,96	0,80
20,00	1,60	1,40	1,20	1,40	1,20	1,00

Bohrfräser "Dummy" mit gegenläufiger Spitzverzahnung - WN
Drill milling cutters "Dummy" with counterwise point cut - Internal standard

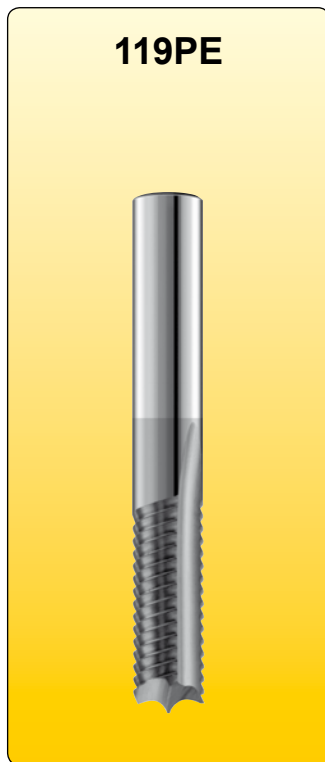

Einsatzgebiete / Range of application

B: Kunststoffe - Faserverstärkte Kunststoffe
 B: Plastics - Reinforced plastic fibres
 B: (AFK - CFK - GFK) B1.4 B1.6 B2.2 B2.4

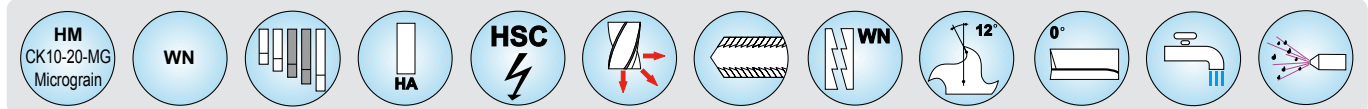
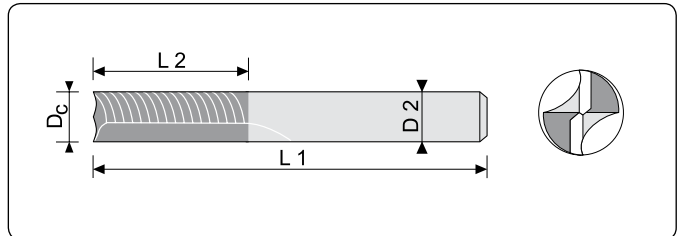

2.
04

D _c h10	L2	L1	D2 h6	119P	119PE
					Beschichtet / Coated
3	12	50	3	119P.030031250	119P.030031250E
3	18	75	3	119P.030031875	119P.030031875E
4	14	50	4	119P.040041450	119P.040041450E
4	20	75	4	119P.040042075	119P.040042075E
5	16	50	5	119P.050051650	119P.050051650E
5	25	75	5	119P.050052575	119P.050052575E
6	20	60	6	119P.060062060	119P.060062060E
6	35	100	6	119P.0600635100	119P.0600635100E
8	22	63	8	119P.080082263	119P.080082263E
8	40	100	8	119P.0800840100	119P.0800840100E
10	25	72	10	119P.100102572	119P.100102572E
10	50	125	10	119P.1001050125	119P.1001050125E
12	30	83	12	119P.120123083	119P.120123083E
12	60	125	12	119P.1201260125	119P.1201260125E
16	35	92	16	119P.160163592	119P.160163592E
16	75	150	16	119P.1601675150	119P.1601675150E
20	45	104	20	119P.2002045104	119P.2002045104E
20	75	150	20	119P.2002075150	119P.2002075150E

Kunststoff-Fräser gerade genutet - große Spannuten - mit Spanteiler - WN
End mills for composite materials - straight flute - with chip breaker - Internal standard



Einsatzgebiete / Range of application

B: Kunststoffe - Faserverstärkte Kunststoffe
 B: Plastics - Reinforced plastic fibres
 (AFK - CFK - GFK) B1.4 B2.1-2.4

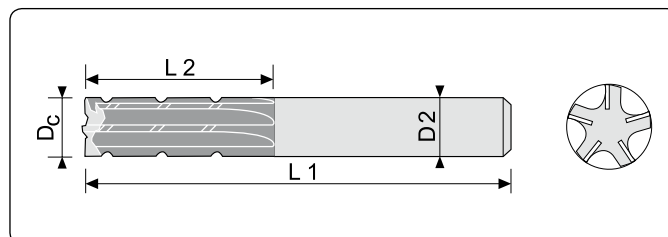

2.
04

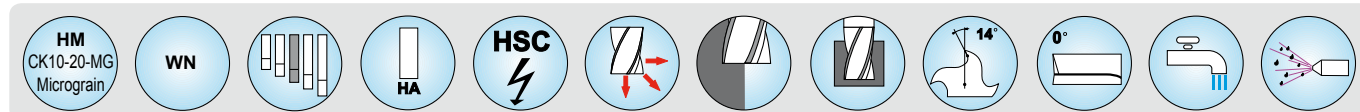

D _c h10	L2	L1	D2 h6	Z	65SU	65SUE
						Beschichtet / Coated
2	7	57	6	5	65SU.020060757	65SU.020060757E
3	12	57	6	5	65SU.030061257	65SU.030061257E
4	14	57	6	5	65SU.040061457	65SU.040061457E
5	16	57	6	5	65SU.050061657	65SU.050061657E
6	18	57	6	5	65SU.060061857	65SU.060061857E
8	20	63	8	5	65SU.080082063	65SU.080082063E
10	25	72	10	5	65SU.100102572	65SU.100102572E
12	30	83	12	5	65SU.120123083	65SU.120123083E

Kunststoff Fräser - 10° Rechtsdrall - grobe gegenläufige Spanteiler - WN
End mills for composite materials - 10° right helix - large counterwise chip breaker - Internal standard



Einsatzgebiete / Range of application

B: Kunststoffe - Faserverstärkte Kunststoffe
 B: Plastics - Reinforced plastic fibres
 (AFK - CFK - GFK) B1.4 B2.1-2.4

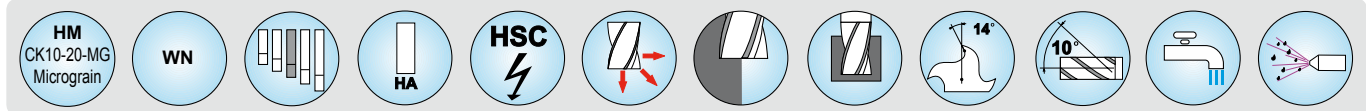
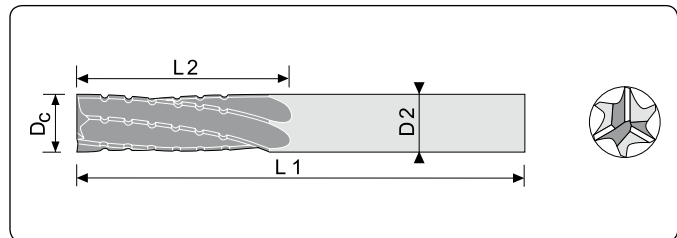

2.04

D _c h10	L2	L1	D2 h6	Z	66SU	66SUE
						Beschichtet / Coated
2	7	57	6	6	66SU.020060757	66SU.020060757E
3	12	57	6	6	66SU.030061257	66SU.030061257E
4	20	57	6	6	66SU.040062057	66SU.040062057E
5	16	57	6	6	66SU.050061657	66SU.050061657E
6	18	57	6	6	66SU.060061857	66SU.060061857E
6	35	75	6	6	66SU.060063575	66SU.060063575E
8	20	63	8	6	66SU.080082063	66SU.080082063E
8	40	100	8	6	66SU.0800840100	66SU.0800840100E
10	25	72	10	6	66SU.100102572	66SU.100102572E
12	30	83	12	6	66SU.120123083	66SU.120123083E

CFK Fräser - kreuzverzahnt - mit Stirnverzahnung Z=2 - WN
End mills for Carbonfibre - with two frontal teeth Z=2 - Internal standard

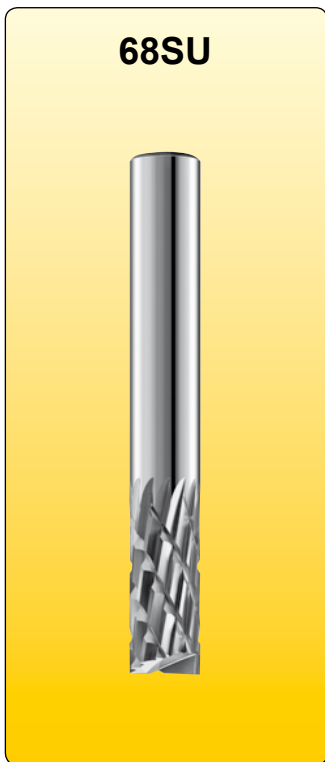

Einsatzgebiete / Range of application

B: Faserverstärkte Kunststoffe
 B: Reinforced plastic fibres
 B1.4 - B2.3

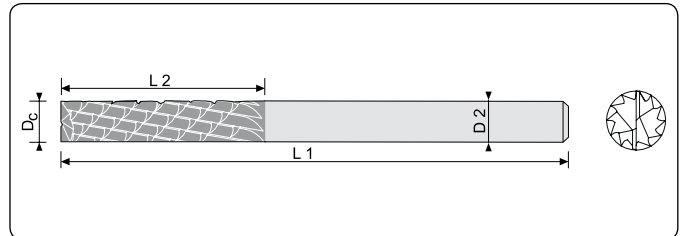

2.
04

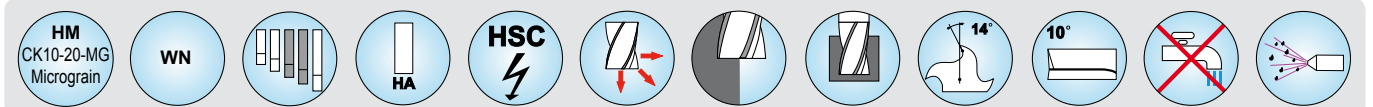

D _c h10	L2	L1	D2 h6	68SU	68SUD
					Beschichtet / Coated
5	16	60	6	68SU.050061660	68SU.050061660D
5	28	75	6	68SU.050062875	68SU.050062875D
6	20	60	6	68SU.060062060	68SU.060062060D
6	35	75	6	68SU.060063575	68SU.060063575D
8	22	63	8	68SU.080082263	68SU.080082263D
8	40	100	8	68SU.0800840100	68SU.0800840100D
10	25	72	10	68SU.100102572	68SU.100102572D
10	50	100	10	68SU.1001050100	68SU.1001050100D
12	30	83	12	68SU.120123083	68SU.120123083D
12	50	100	12	68SU.1201250100	68SU.1201250100D
16	35	92	16	68SU.160163592	68SU.160163592D
16	60	125	16	68SU.1601660125	68SU.1601660125D

Kunststoff Fräser - kreuzverzahnt - ohne Stirnverzahnung - WN
End mills for composite materials - cross cut - without end cut - Internal standard

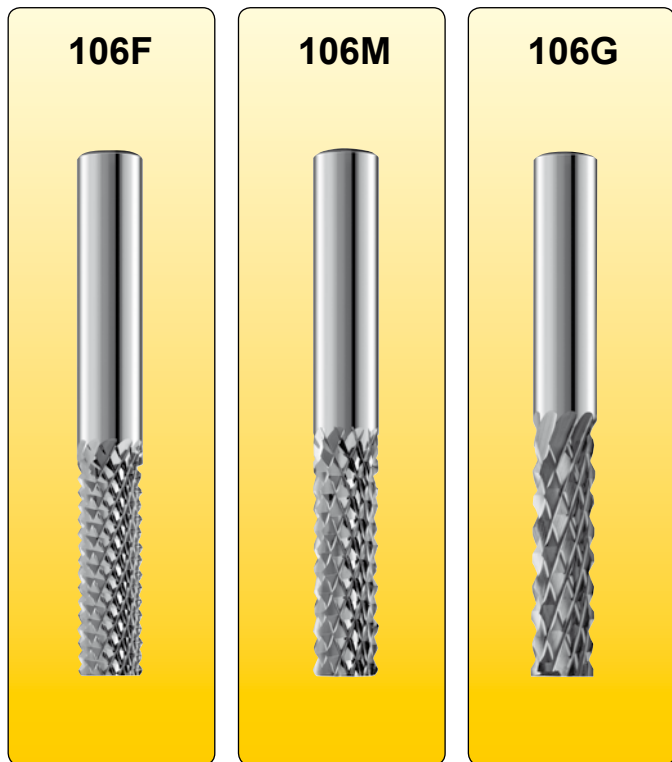

Einsatzgebiete / Range of application

A: Legierungen / Light alloys
 A1.7

B: Kunststoffe - Faserverstärkte Kunststoffe
 B: Plastics - Reinforced plastic fibres
 (AFK - CFK - GFK) - B1.4 B1.1-1.3 B2.1-2.4

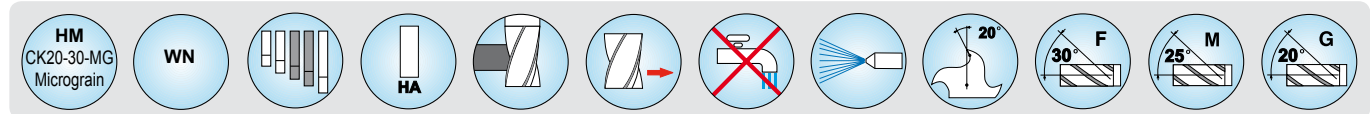
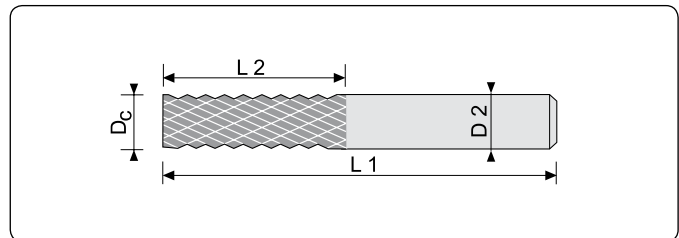

2.
04

D _c h10	L2	L1	D2 h6	106F	106M	106G
2	7	40	2	106F.020020740	106M.020020740	106G.020020740
2	7	50	6	106F.020060750	106M.020060750	106G.020060750
3	10	40	3	106F.030031040	106M.030031040	106G.030031040
3	12	50	6	106F.030061250	106M.030061250	106G.030061250
3,5	12	40	3,5	106F.035351240	106M.035351240	106G.035351240
4	15	40	4	106F.040041540	106M.040041540	106G.040041540
4	20	50	6	106F.040062050	106M.040062050	106G.040062050
4,5	15	50	4,5	106F.045451550	106M.045451550	106G.045451550
5	16	50	5	106F.050051650	106M.050051650	106G.050051650
5	25	75	6	106F.050062575	106M.050062575	106G.050062575
6	18	50	6	106F.060061850	106M.060061850	106G.060061850
6	35	75	6	106F.060063575	106M.060063575	106G.060063575
7	22	60	7	106F.070072260	106M.070072260	106G.070072260
8	25	63	8	106F.080082563	106M.080082563	106G.080082563
8	40	100	8	106F.0800840100	106M.0800840100	106G.0800840100
9	25	63	9	106F.090092563	106M.090092563	106G.090092563
10	30	72	10	106F.100103072	106M.100103072	106G.100103072
12	32	83	12	106F.120123283	106M.120123283	106G.120123283
14	32	83	14	106F.140143283	106M.140143283	106G.140143283
16	36	92	16	106F.160163692	106M.160163692	106G.160163692
18	40	92	18	106F.180184092	106M.180184092	106G.180184092
20	45	104	20	106F.2002045104	106M.2002045104	106G.2002045104
Verzahnung - Typ Cut type				F fein F fine 	M mittel M medium 	G grob G course

Kunststoff Fräser - kreuzverzahnt - mit Stirnverzahnung - WN
End mills for composite materials - cross cut - with end cut - Internal standard

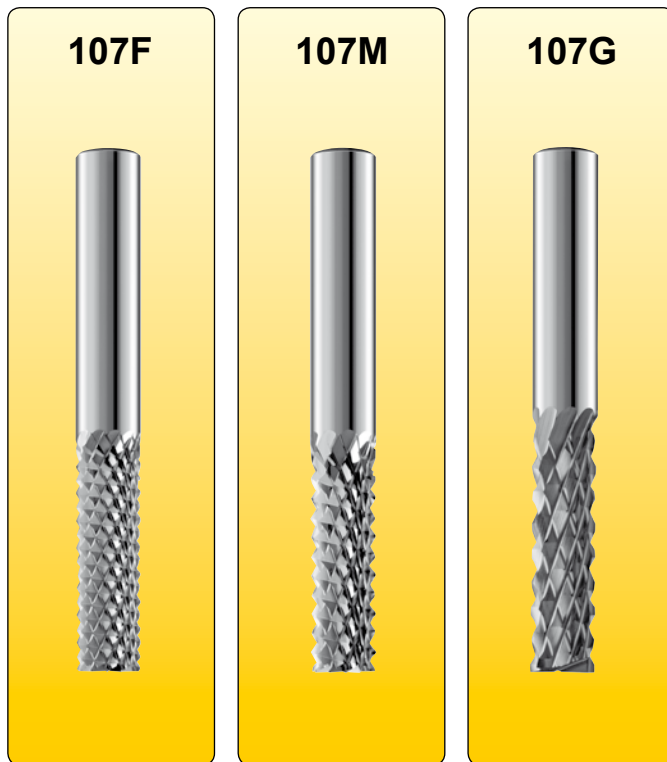

Einsatzgebiete / Range of application

A: Legierungen / Light alloys
 A1.7

B: Kunststoffe - Faserverstärkte Kunststoffe
 B: Plastics - Reinforced plastic fibres
 (AFK - CFK - GFK) - B1.4 B1.1-1.3 B2.1-2.4

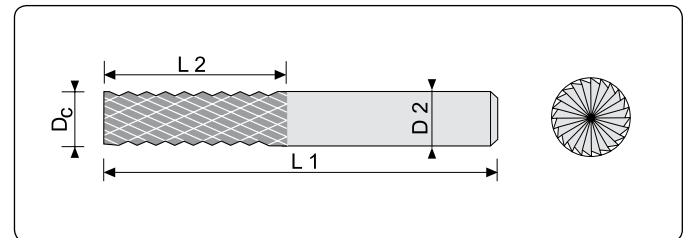

2.
04

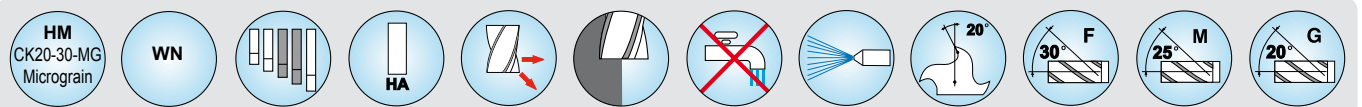

D _c h10	L2	L1	D2 h6	107F	107M	107G
2	7	40	2	107F.020020740	107M.020020740	107G.020020740
2	7	50	6	107F.020060750	107M.020060750	107G.020060750
3	10	40	3	107F.030031040	107M.030031040	107G.030031040
3	12	50	6	107F.030061250	107M.030061250	107G.030061250
3,5	12	40	3,5	107F.035351240	107M.035351240	107G.035351240
4	15	40	4	107F.040041540	107M.040041540	107G.040041540
4	20	50	6	107F.040062050	107M.040062050	107G.040062050
4,5	15	50	4,5	107F.045451550	107M.045451550	107G.045451550
5	16	50	5	107F.050051650	107M.050051650	107G.050051650
5	25	75	6	107F.050062575	107M.050062575	107G.050062575
6	18	50	6	107F.060061850	107M.060061850	107G.060061850
6	35	75	6	107F.060063575	107M.060063575	107G.060063575
7	22	60	7	107F.070072260	107M.070072260	107G.070072260
8	25	63	8	107F.080082563	107M.080082563	107G.080082563
8	40	100	8	107F.0800840100	107M.0800840100	107G.0800840100
9	25	63	9	107F.090092563	107M.090092563	107G.090092563
10	30	72	10	107F.100103072	107M.100103072	107G.100103072
12	32	83	12	107F.120123283	107M.120123283	107G.120123283
14	32	83	14	107F.140143283	107M.140143283	107G.140143283
16	36	92	16	107F.160163692	107M.160163692	107G.160163692
18	40	92	18	107F.180184092	107M.180184092	107G.180184092
20	45	104	20	107F.2002045104	107M.2002045104	107G.2002045104
Verzahnung - Typ Cut type				F fein F fine 	M mittel M medium 	G grob G course

Bohrnutenfräser - kreuzverzahnt - WN
Drill slot milling cutters - cross cut - Internal standard

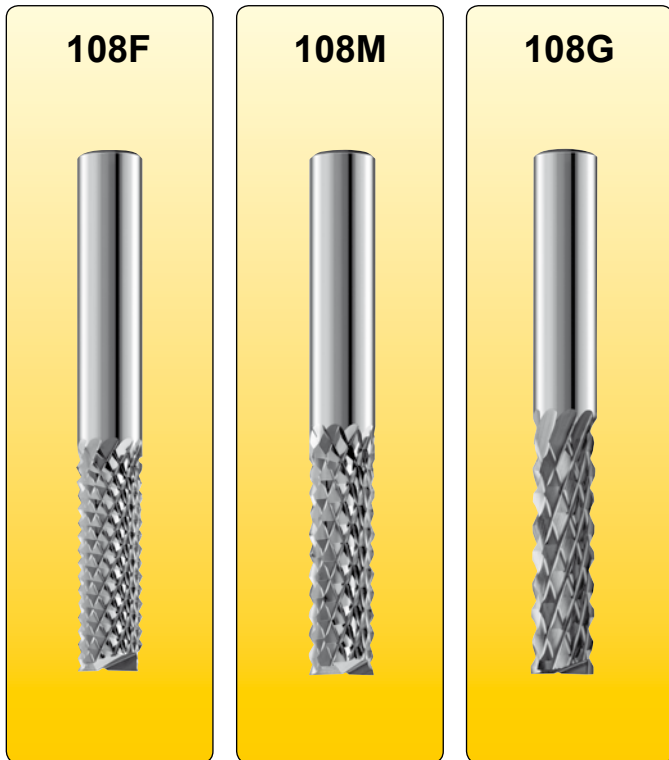

Einsatzgebiete / Range of application

A: Legierungen / Light alloys
 A1.7

B: Kunststoffe - Faserverstärkte Kunststoffe
 B: Plastics - Reinforced plastic fibres
 (AFK - CFK - GFK) - B1.4 B1.1-1.3 B2.1-2.4

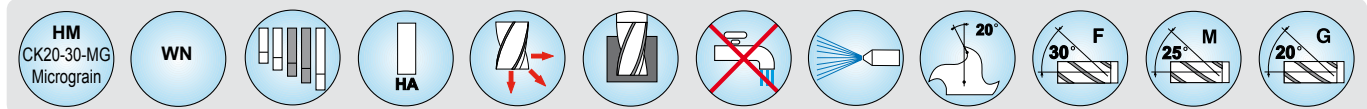
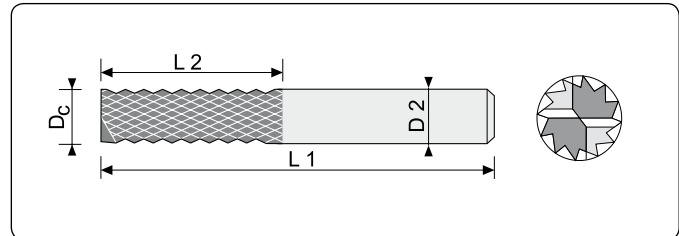

2.
04

D _c h10	L2	L1	D2 h6	108F	108M	108G
2	7	40	2	108F.020020740	108M.020020740	108G.020020740
2	7	50	6	108F.020060750	108M.020060750	108G.020060750
3	10	40	3	108F.030031040	108M.030031040	108G.030031040
3	12	50	6	108F.030061250	108M.030061250	108G.030061250
3,5	12	40	3,5	108F.035351240	108M.035351240	108G.035351240
4	15	40	4	108F.040041540	108M.040041540	108G.040041540
4	20	50	6	108F.040062050	108M.040062050	108G.040062050
4,5	15	50	4,5	108F.045451550	108M.045451550	108G.045451550
5	16	50	5	108F.050051650	108M.050051650	108G.050051650
5	25	75	6	108F.050062575	108M.050062575	108G.050062575
6	18	50	6	108F.060061850	108M.060061850	108G.060061850
6	35	75	6	108F.060063575	108M.060063575	108G.060063575
7	22	60	7	108F.070072260	108M.070072260	108G.070072260
8	25	63	8	108F.080082563	108M.080082563	108G.080082563
8	40	100	8	108F.0800840100	108M.0800840100	108G.0800840100
9	25	63	9	108F.090092563	108M.090092563	108G.090092563
10	30	72	10	108F.100103072	108M.100103072	108G.100103072
12	32	83	12	108F.120123283	108M.120123283	108G.120123283
14	32	83	14	108F.140143283	108M.140143283	108G.140143283
16	36	92	16	108F.160163692	108M.160163692	108G.160163692
18	40	92	18	108F.180184092	108M.180184092	108G.180184092
20	45	104	20	108F.2002045104	108M.2002045104	108G.2002045104
Verzahnung - Typ Cut type				F fein F fine 	M mittel M medium 	G grob G course

Bohrfräser - kreuzverzahnt - WN Drill milling cutters - cross cut - Internal standard

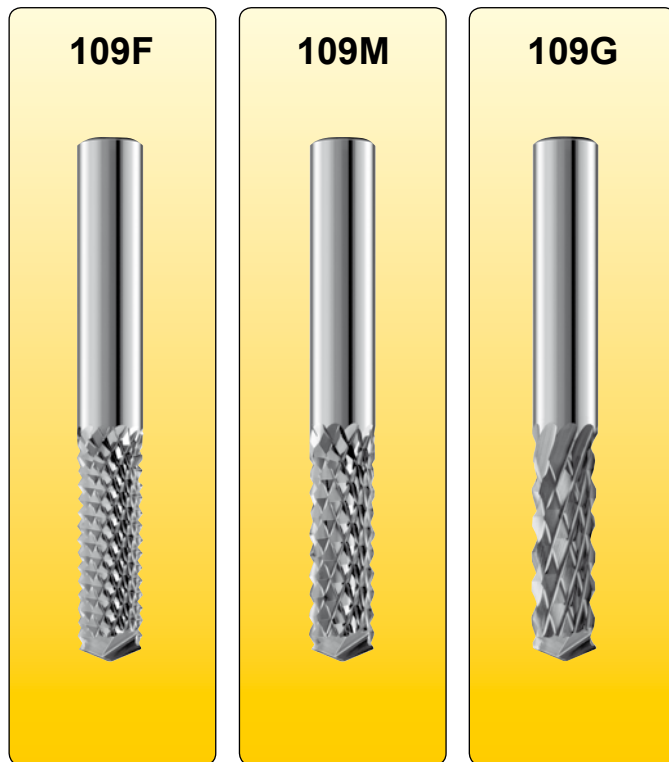

Einsatzgebiete / Range of application

A: Legierungen / Light alloys
A1.7

B: Kunststoffe - Faserverstärkte Kunststoffe
B: Plastics - Reinforced plastic fibres
(AFK - CFK - GFK) - B1.4 B1.1-1.3 B2.1-2.4

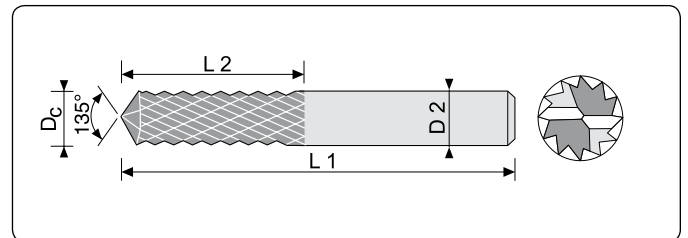

2.
04

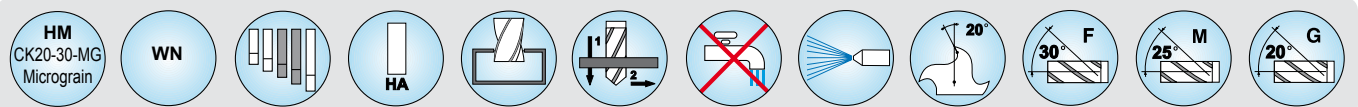

D _c h10	L2	L1	D2 h6	109F	109M	109G
2	7	40	2	109F.020020740	109M.020020740	109G.020020740
2	7	50	6	109F.020060750	109M.020060750	109G.020060750
3	10	40	3	109F.030031040	109M.030031040	109G.030031040
3	12	50	6	109F.030061250	109M.030061250	109G.030061250
3,5	12	40	3,5	109F.035351240	109M.035351240	109G.035351240
4	15	40	4	109F.040041540	109M.040041540	109G.040041540
4	20	50	6	109F.040062050	109M.040062050	109G.040062050
4,5	15	50	4,5	109F.045451550	109M.045451550	109G.045451550
5	16	50	5	109F.050051650	109M.050051650	109G.050051650
5	25	75	6	109F.050062575	109M.050062575	109G.050062575
6	18	50	6	109F.060061850	109M.060061850	109G.060061850
6	35	75	6	109F.060063575	109M.060063575	109G.060063575
7	22	60	7	109F.070072260	109M.070072260	109G.070072260
8	25	63	8	109F.080082563	109M.080082563	109G.080082563
8	40	100	8	109F.0800840100	109M.0800840100	109G.0800840100
9	25	63	9	109F.090092563	109M.090092563	109G.090092563
10	30	72	10	109F.100103072	109M.100103072	109G.100103072
12	32	83	12	109F.120123283	109M.120123283	109G.120123283
14	32	83	14	109F.140143283	109M.140143283	109G.140143283
16	36	92	16	109F.160163692	109M.160163692	109G.160163692
18	40	92	18	109F.180184092	109M.180184092	109G.180184092
20	45	104	20	109F.2002045104	109M.2002045104	109G.2002045104
Verzahnung - Typ Cut type				F fein F fine	M mittel M medium	G grob G course

Radiusfräser - kreuzverzahnt - WN
Ball nose end mills - cross cut - Internal standard

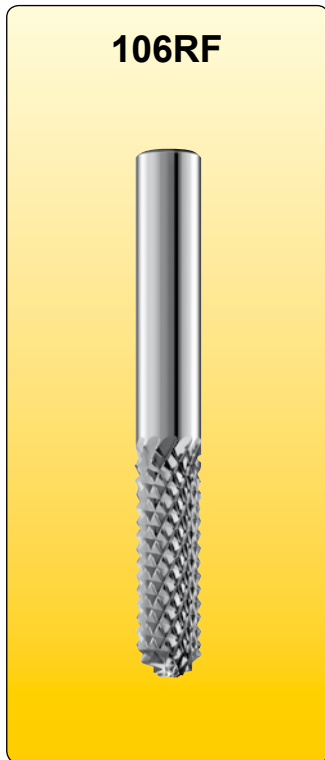

Einsatzgebiete / Range of application

B: Kunststoffe - Faserverstärkte Kunststoffe
 B: *Plastics - Reinforced plastic fibres*
 (AFK - CFK - GFK) - B1.4 B1.1-1.3 B2.1-2.4

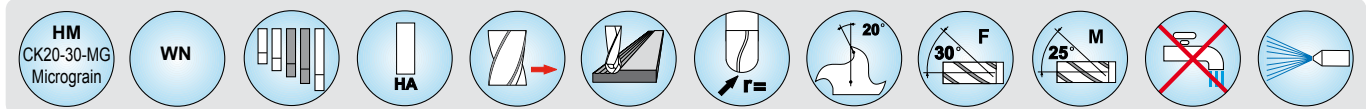
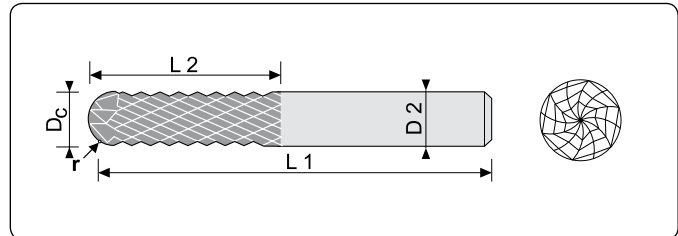

2.
04

D _c h10	L2	L1	D2 h6	r	106RF	106RM
3	10	40	3	1,5	106RF.030031040	106RM.030031040
3	12	50	6	1,5	106RF.030061250	106RM.030061250
4	15	40	4	2	106RF.040041540	106RM.040041540
4	20	50	6	2	106RF.040062050	106RM.040062050
5	16	50	5	2,5	106RF.050051650	106RM.050051650
5	25	75	6	2,5	106RF.050062575	106RM.050062575
6	18	50	6	3	106RF.060061850	106RM.060061850
6	35	75	6	3	106RF.060063575	106RM.060063575
8	25	63	8	4	106RF.080082563	106RM.080082563
8	40	100	8	4	106RF.0800840100	106RM.0800840100
10	30	72	10	5	106RF.100103072	106RM.100103072
12	32	83	12	6	106RF.120123283	106RM.120123283
16	36	92	16	8	106RF.160163692	106RM.160163692
20	45	104	20	10	106RF.2002045104	106RM.2002045104
Verzahnung - Typ Cut type					RF fein RF fine	RM mittel RM medium

Schafffräser Z=2 Drall 14° - ähnlich DIN 6527-L

"ULTRA Ra" Speed Line mit feingeläppten Spannuten

End mills Z=2 Helix 14° - Similar to DIN 6527-L

"ULTRA Ra" Speed Line with fine lapped chip flutes

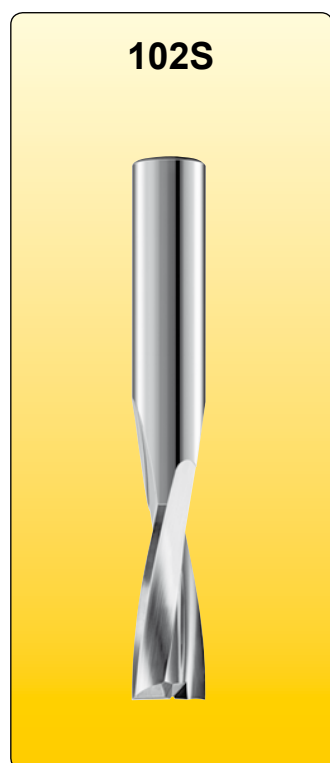
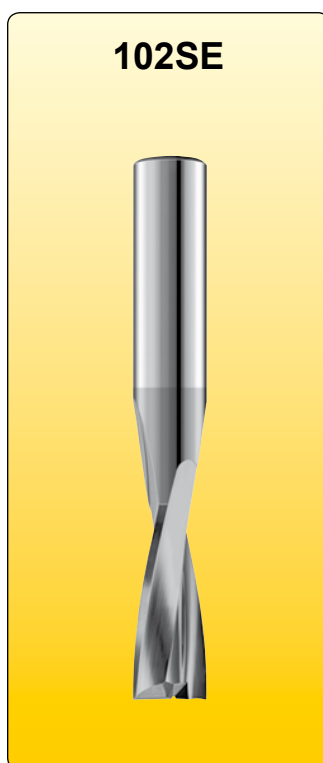
102S

102SE

Einsatzgebiete / Range of application

A: Legierungen / Light alloys

A1.1-1.2

B: Kunststoffe - Faserverstärkte Kunststoffe

 B: *Plastics - Reinforced plastic fibres*

B1.1-1.5 B2.1-2.4

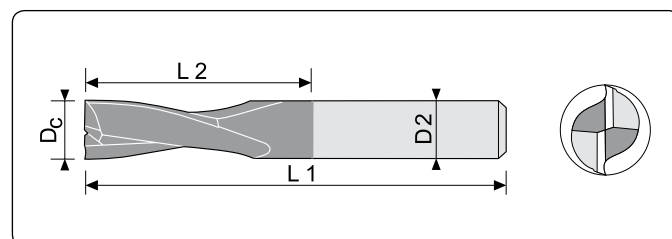
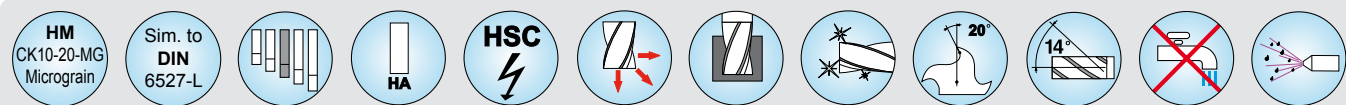

**2.
04**

D _c h10	L2	L1	D2 h6	102S	102SE
					Beschichtet / Coated
2	5	57	6	102S.020060557	102S.020060557E
3	10	57	6	102S.030061057	102S.030061057E
4	13	57	6	102S.040061357	102S.040061357E
5	15	57	6	102S.050061557	102S.050061557E
6	18	57	6	102S.060061857	102S.060061857E
7	20	63	8	102S.070082063	102S.070082063E
8	20	63	8	102S.080082063	102S.080082063E
9	22	72	10	102S.090102272	102S.090102272E
10	25	72	10	102S.100102572	102S.100102572E
12	30	83	12	102S.120123083	102S.120123083E

Honeycomb Fräser - grobe gegenläufige Spanteiler - WN
End mills for honeycomb - large counterwise chip breaker - Internal standard

Einsatzgebiete / Range of application

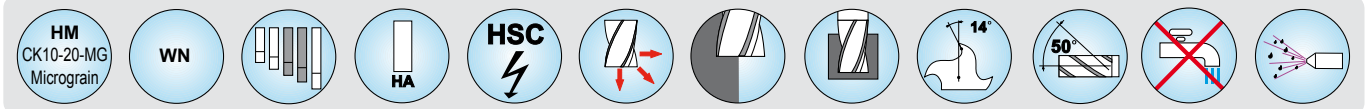
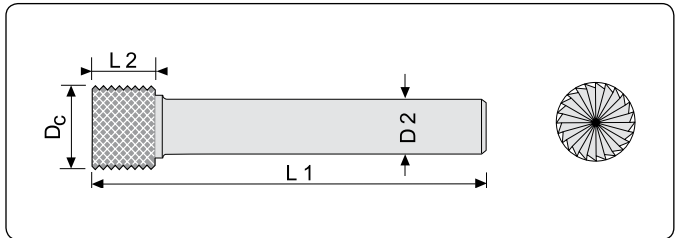
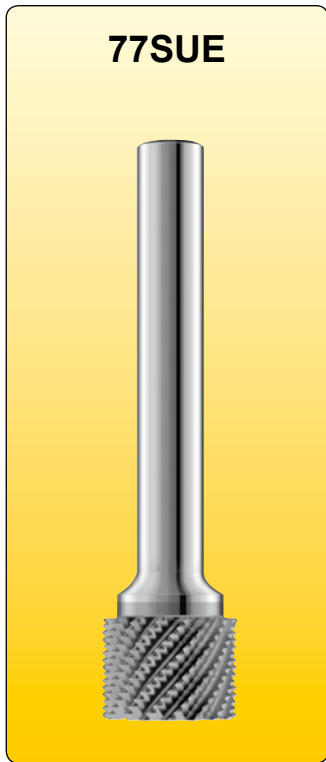
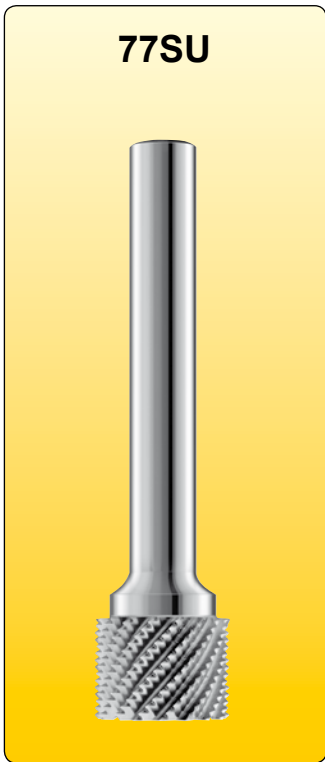
B: Kunststoffe - Faserverstärkte Kunststoffe
 B: Plastics - Reinforced plastic fibres
 (AFK - CFK - GFK) B1.4 B2.1-2.4



**2.
04**

D _c h10	L2	L1	D2 h6	77SU	77SUE
					Beschichtet / Coated
6	16	50	6	77SU.060061650	77SU.060061650E
8	19	63	8	77SU.080081963	77SU.080081963E
10	22	72	10	77SU.100102272	77SU.100102272E
12	26	83	12	77SU.120122683	77SU.120122683E
14	17	100	12	77SU.1401217100	77SU.1401217100E
16	17	100	12	77SU.1601217100	77SU.1601217100E
20	17	100	12	77SU.2001217100	77SU.2001217100E
24	10	100	12	77SU.2401210100	77SU.2401210100E
24	17	100	12	77SU.2401217100	77SU.2401217100E
44*	17	100	12	77SU.4401217100	77SU.4401217100E

* senkrechtes Eintauchen nicht möglich / Vertical machining not allowed

2.
04



2.
05

Fräser für Kunststoffe und Leichtmetalle
End mills for plastics and light alloys

2.755
2.752

Schnittgeschwindigkeiten V_c (m/min) (Richtwerte) für ULTRA Ra- und PIRAÑA Fräser
Cutting speed V_c (m/min) (approx. values) for ULTRA Ra and PIRAÑA end mills

Gruppe A: Aluminium - Alu-Legierungen - Kupfer - Kupferlegierungen - Magnesium Group A: Aluminium - Alu-alloys - Copper - Copper alloys - Magnesium				
	Werkstoff Bezeichnung Material description	Zugfestigkeit Strength N/mm ²	VHM Carbide V_c (m/min)	Cer-Al
A 1.1	G-AlMg3	130 - 190	350	600
A 1.2	Al 99.5 / F13	100 - 250	400	650
A 1.3	GDAISI17Cu4	180 - 250		■ 250
A 1.4	GD-AISI12	220 - 300		■ 350
A 1.5	GD-AISI9Cu3	240 - 320	300	350
A 1.6	AlCuMg1 / F39	300 - 500	400	650
A 1.7	MMC - faserarmiert	600 - 1400		■ 300
A 2.1	E-Cu	220 - 350	260	350
A 2.2	GCuSn5ZnPb / Rg5	150 - 350	300	400
A 2.3	GCuSn7ZnPb / Rg7	150 - 350	260	350
A 2.4	CuZn40 /Ms60	340 - 500	260	350
A 2.5	CuZn39Pb2 / Ms58	350 - 500	260	350
A 2.6	CuZn37 /Ms63	300 - 550	260	350
A 2.7	CuAl10Ni	500 - 800	200	300
A 3.1	Ampco 16	630		65
A 3.2	Ampco 20	600		25
A 4.1	MgAl6	300 - 500	200	300
A 4.2	GMgAl9Zn1	300 - 500	250	350

■ Bei diesen Werkstoffen ist die Cer-Al Beschichtung zu empfehlen
 ■ By machining these materials Cer-Al coating is recommended

**2.
05**

Schnittgeschwindigkeiten V_c (m/min) - Drehzahlen n (min⁻¹)
Cutting speeds V_c (m/min) - Revolution per minute n (min⁻¹)

D_c (mm)	V_c (m/min)												
	25	50	75	100	150	200	250	300	400	500	600	700	800
2,00	3981	7962	11943	15924	23885	31847	39809	47771	63694				
2,50	3185	6369	9554	12739	19108	25478	31847	38217	50955	63694			
3,00	2654	5308	7962	10616	15924	21231	26539	31847	42463	53079	63694	74310	
3,50	2275	4550	6824	9099	13649	18198	22748	27298	36397	45496	54595	63694	72793
4,00	1990	3981	5971	7962	11943	15924	19904	23885	31847	39809	47771	55732	63694
4,50	1769	3539	5308	7077	10616	14154	17693	21231	28309	35386	42463	49540	56617
5,00	1592	3185	4777	6369	9554	12739	15924	19108	25478	31847	38217	44586	50955
6,00	1327	2654	3981	5308	7962	10616	13270	15924	21231	26539	31847	37155	42463
8,00	995	1990	2986	3981	5971	7962	9952	11943	15924	19904	23885	27866	31847
10,00	796	1592	2389	3185	4777	6369	7962	9554	12739	15924	19108	22293	25478
12,00	663	1327	1990	2654	3981	5308	6635	7962	10616	13270	15924	18577	21231
14,00	569	1137	1706	2275	3412	4550	5687	6824	9099	11374	13649	15924	18198
16,00	498	995	1493	1990	2986	3981	4976	5971	7962	9952	11943	13933	15924
18,00	442	885	1327	1769	2654	3539	4423	5308	7077	8846	10616	12385	14154
20,00	398	796	1194	1592	2389	3185	3981	4777	6369	7962	9554	11146	12739

Schaftfräser - "ULTRA" Ra - Speed Line und "PIRAÑA"
 End mills - "ULTRA" Ra - Speed Line and "PIRAÑA" end mills

Gruppe A: Aluminium - Alu-Legierungen - Kupfer - Kupferlegierungen - Magnesium Group A: Aluminium - Aluminium alloys - Copper - Copper alloys - Magnesium															
	Eck-/ Konturenfräsen Side-Contour milling					Nutenfräsen Slot milling					Kopierfräsen - Zeilenfräsen Copying mills - Z levelling				
	$a_p = 1,5 \times D_c$ $a_e = 0,20 \times D_c$					$a_p = 0,4 \times D_c$					$a_p = 1,0 \times D_c$ $a_e = 0,25 \times D_c$				
D _c (mm)															
	2,0	2,5	3,0	3,5	4,0	5,0	6,0	8,0	10,0	12,00	14,0	16,0	18,0	20,0	25,0
f _z (mm)															
A 1.1	0,011	0,014	0,018	0,020	0,023	0,029	0,031	0,045	0,054	0,063	0,072	0,090	0,099	0,108	0,119
A 1.2	0,011	0,015	0,019	0,021	0,025	0,030	0,032	0,048	0,057	0,067	0,076	0,095	0,105	0,114	0,125
A 1.3	0,009	0,012	0,015	0,017	0,020	0,024	0,026	0,038	0,045	0,053	0,060	0,075	0,083	0,090	0,099
A 1.4	0,010	0,013	0,016	0,018	0,021	0,026	0,027	0,040	0,048	0,056	0,064	0,080	0,088	0,096	0,106
A 1.5	0,010	0,013	0,016	0,018	0,021	0,026	0,027	0,040	0,048	0,056	0,064	0,080	0,088	0,096	0,106
A 1.6	0,011	0,015	0,019	0,021	0,025	0,030	0,032	0,048	0,057	0,067	0,076	0,095	0,105	0,114	0,125
A 1.7	0,005	0,007	0,009	0,010	0,012	0,014	0,015	0,023	0,027	0,032	0,036	0,045	0,050	0,054	0,059
A 2.1	0,007	0,010	0,012	0,013	0,016	0,019	0,020	0,030	0,036	0,042	0,048	0,060	0,066	0,072	0,079
A 2.2	0,007	0,010	0,012	0,013	0,016	0,019	0,020	0,030	0,036	0,042	0,048	0,060	0,066	0,072	0,079
A 2.3	0,007	0,010	0,012	0,013	0,016	0,019	0,020	0,030	0,036	0,042	0,048	0,060	0,066	0,072	0,079
A 2.4	0,007	0,009	0,011	0,012	0,014	0,018	0,019	0,028	0,033	0,039	0,044	0,055	0,061	0,066	0,073
A 2.5	0,007	0,010	0,012	0,013	0,016	0,019	0,020	0,030	0,036	0,042	0,048	0,060	0,066	0,072	0,079
A 2.6	0,007	0,009	0,011	0,012	0,014	0,018	0,019	0,028	0,033	0,039	0,044	0,055	0,061	0,066	0,073
A 2.7	0,007	0,010	0,012	0,013	0,016	0,019	0,020	0,030	0,036	0,042	0,048	0,060	0,066	0,072	0,079
A 3.1	0,006	0,008	0,010	0,011	0,013	0,016	0,017	0,025	0,030	0,035	0,040	0,050	0,055	0,060	0,066
A 3.2	0,004	0,006	0,007	0,008	0,009	0,011	0,012	0,018	0,021	0,025	0,028	0,035	0,039	0,042	0,046
A 4.1	0,011	0,014	0,018	0,020	0,023	0,029	0,031	0,045	0,054	0,063	0,072	0,090	0,099	0,108	0,119
A 4.2	0,011	0,015	0,019	0,021	0,025	0,030	0,032	0,048	0,057	0,067	0,076	0,095	0,105	0,114	0,125

Übersicht von gebräuchlichen Kunststoffen Summary of common composite materials in use

Duroplaste - kurzspanig Thermosets - short chipping	
Werkstoff - Gruppe B 1.1 Material - Group B 1.1	Festigkeit N/mm ² Strength N/mm ²
Albanit	110
Bakelit	110
Ferrozell	110
Harnstoff-Formaldehyd	80
Melamin-Formaldehyd	80
MF	80
Pertinax	110
Phenol-Formaldehyd	80
Resopal	80
UP	80

Thermoplaste - langspanig Thermoplastics - long chipping	
Werkstoff - Gruppe B 1.2 Material - Group B 1.2	Festigkeit N/mm ² Strength N/mm ²
ABS	35-50
ABC Copolymere	80
Bayolan	70-75
Dogalan	80
Dolin	50-70
Durethan 43	
Fluon	20-40
Hostafion TF	20-40
Hostaform	50-70
Hostalen	20-80
Hostalen PP	20-38
Hostalit	35-60
Hostyren N	40-65
HostyrenS	22-50
Lupolen	20-30/80
Luran	78
Lustran	80
Makralon 80	
Makrolon 5	
Novodur	35-56
Novolen	21-38
PA 6	43/57/80
PA 66	43/57/80
PC	5
PE-HD	20-30
Plexiglas	70-76
PMMA	70-78
Polyamid 43/57/80	
Polyamid 66	43/57/80
Polykarbonate	5
Polyethylen	20-30/80

Thermoplaste - langspanig Thermoplastics - long chipping	
Werkstoff - Gruppe B 1.2 Material - Group B 1.2	Festigkeit N/mm ² Strength N/mm ²
Fortsetzung <i>To be continued</i>	
Polymethylmethacrylat	70-76
Polyoxymethylen	50/70/80
Polypropylen	21-37
Polystrol	80
Polystyrol	2-/50/40-65
Polytetrafluorethylen	20-40
Polyvinylchlorid	32-60
PO M	50/70/80
PP	21-37
PS	40-65
PTFE	20-40
PVC-U	35-60
Resanit	70-76
Risitex	80
Rilsan	40/57/80
S/B	22-50
SAN	78
Solvic	35-60
Styrol Acrylnitril	78
Styrol Buladien	22-50
Teflon	20-40
Trogamid T	48/57/80
Ultraform 50/70/80	
Vestamid 43/57/80	
Vestolen	20-30/80
Vestolen P	21-37
Vestyron	22-50/80
Vostyron	40-50
Vinol	35-60
Vinoflex	35-60

Faserverstärkte Kunststoffe Reinforced plastic fibres	
Werkstoff - Gruppe B 1.4 Material - Group B 1.4	Festigkeit N/mm ² Strength N/mm ²
AFK - Aramidfaser / Aramid fiber	800-1000
	1000-1500
CFK - Kohlefaser / Carbon fiber	800-1000
	1000-1500
GFK - Glasfaser / Fiberglass	800-1000
	1000-1500

Schnittgeschwindigkeit V_c (m/min) - für die Kunststoffbearbeitung
Cutting speed V_c (m/min) - for machining of composite materials

Schnittgeschwindigkeit V_c (m/min) / Cutting speed V_c (m/min)

Gruppe B: Kunststoffe - faserverstärkte Kunststoffe - NE Werkstoffe
Group B: Plastics - Reinforced plastic fibres - Nonferrous materials

	Werkstoffbezeichnung Material description	Zugfestigkeit N/mm² Strength N/mm²	VHM Carbide V_c (m/min)	Cer-P V_c (m/min)
B 1.1	Duroplaste / Thermosets	80 - 110	200 - 300	300 - 600
B 1.2	Thermoplaste / Thermoplastics	≤ 80	250 - 400	400 - 650
B 1.3	Polykarbonate / Polycarbonate	≤ 20	200 - 350	300 - 450
B 1.4	AFK - CFK - GFK	800-1500	100 - 200	150 - 300
B 1.5	Plexiglas / Plexiglass	70 - 80	150 - 300	300 - 450
B 2.1	Hartholz / Hard wood	≤ 255	200 - 300	300 - 450
B 2.2	Hartgummi / Hard rubber	≤ 255	50-150	100 - 150
B 2.3	NE-Werkstoffe / Nonferrous materials	≤ 255	200 - 350	250 - 350
B 2.4	Presskarton / Pressed carton	≤ 255	200 - 250	200 - 350

Drehzahl n (min⁻¹)
Revolution per minute n (min⁻¹)

V_c (m/min)	D_c (mm)										
	2,00	3,00	4,00	5,00	6,00	8,00	10,00	12,00	14,00	16,00	20,00
Drehzahl n (min⁻¹) / Revolution n (min⁻¹)											
100	15924	10616	7962	6369	5308	3981	3185	2654	2275	1990	1592
150	23885	15924	11943	9554	7962	5971	4777	3981	3412	2986	2389
200	31847	21231	15924	12739	10616	7962	6369	5308	4550	3981	3185
250	39809	26539	19904	15924	13270	9952	7962	6635	5687	4976	3981
300	47771	31847	23885	19108	15924	11943	9554	7962	6824	5971	4777
350	55732	37155	27866	22293	18577	13933	11146	9289	7962	6967	5573
400	63694	42463	31847	25478	21231	15924	12739	10616	9099	7962	6369
450	71656	47771	35828	28662	23885	17914	14331	11943	10237	8957	7166
500	79618	53079	39809	31847	26539	19904	15924	13270	11374	9952	7962
550	87580	58386	43790	35032	29193	21895	17516	14597	12511	10947	8758
600	95541	63694	47771	38217	31847	23885	19108	15924	13649	11943	9554

**2.
05**

Einsatzdaten: f_z (mm) - zur Bearbeitung von Duroplasten (Richtwerte)
 Cutting data: f_z (mm) - for machining of thermosets (approximative values)

DIN 6527-L - WN kurz = f_z (mm) nach Tabelle
 DIN 6527-L - Internal standard short = f_z (mm) acc. to table

WN überlang - extralang = f_z (mm) nach Tabelle x 0,7
 Internal standard long - extra long = f_z (mm) acc. to table x 0,7

Gruppe B: Kunststoffe - Duroplaste - Hartholz - Presskarton Group B: Plastics - Thermosets - Hard wood - Pressed carton					
B 1.1	Schafffräser Flat end mills			Torus- und Radiusfräser Torus- and ball nose	
B 2.1 B 2.4	Eck-/ Konturenfräsen Side-Contour milling		Nutenfräsen Slot milling	Kopierfräsen - Zeilenfräsen Copying mills - Z levelling	
	Schruppen Roughing	Schlichten Finishing		Schruppen Roughing	Schlichten Finishing
	$a_p = 1 \times D_c$ $a_e = 0,5 \times D_c$	$a_p = 1,0 \times D_c$ $a_e = 0,10 \times D_c$	$a_p = 0,5 \times D_c$	$a_p = 0,5 \times D_c$ $a_e = 0,5 \times D_c$	$a_p = 0,03 \times D_c$ $a_e = 0,02 \times D_c$
D_c (mm)	f_z (mm)	f_z (mm)	f_z (mm)	f_z (mm)	f_z (mm)
2,00	0,024	0,018	0,016	0,028	0,024
3,00	0,036	0,027	0,024	0,042	0,036
4,00	0,048	0,036	0,032	0,056	0,048
5,00	0,060	0,045	0,040	0,070	0,060
6,00	0,072	0,054	0,048	0,084	0,072
8,00	0,096	0,072	0,064	0,112	0,096
10,00	0,120	0,090	0,080	0,140	0,120
12,00	0,144	0,108	0,096	0,168	0,144
14,00	0,168	0,126	0,112	0,196	0,168
16,00	0,192	0,144	0,128	0,224	0,192
18,00	0,216	0,162	0,144	0,252	0,216
20,00	0,240	0,180	0,160	0,280	0,240

Einsatzdaten: f_z (mm) - zur Bearbeitung von Thermoplasten und faserverstärkten Kunststoffen
 Cutting data: f_z (mm) - for machining of thermoplastics and reinforced plastic fibres (approx. values)

Kopierfräser - Schafffräser mit und ohne Spanteiler
Copy milling cutters - End mills with and without chip breaker

Gruppe B: Kunststoffe - Thermoplaste - Polycarbonate - NE Metalle - Hartgummi Group B: Plastics - Thermoplastics - Polycarbonate - Nonferrous metals - Hard rubber					
B 1.2 B 1.3 B 2.2 B 2.3	Schafffräser mit und ohne Spanteiler End mills with and without chip breaker			Torus - Radiusfräser Torus - Ball nose milling cutters	
	Eck-/ Konturenfräsen Side-Contour milling		Nutenfräsen Slot milling	Kopierfräsen - Zeilenfräsen Copying mills - Z levelling	
	Schruppen Roughing	Schlichten Finishing		Schruppen Roughing	Schlichten Finishing-
	$a_p = 1,5 \times D_c$ $a_e = 0,8 \times D_c$	$a_p = 1,0 \times D_c$ $a_e = 0,10 \times D_c$	$a_p = 1,0 \times D_c$	$a_p = 0,5 \times D_c$ $a_e = 0,5 \times D_c$	$a_p = 0,05 \times D_c$ $a_e = 0,02 \times D_c$
D_c (mm)	f_z (mm)	f_z (mm)	f_z (mm)	f_z (mm)	f_z (mm)
2,00	0,024	0,022	0,017	0,037	0,030
3,00	0,036	0,033	0,026	0,056	0,045
4,00	0,048	0,044	0,034	0,074	0,060
5,00	0,060	0,055	0,043	0,093	0,075
6,00	0,072	0,066	0,051	0,111	0,090
8,00	0,096	0,088	0,068	0,148	0,120
10,00	0,120	0,110	0,085	0,185	0,150
12,00	0,144	0,132	0,102	0,222	0,180
14,00	0,168	0,154	0,119	0,259	0,210
16,00	0,192	0,176	0,136	0,296	0,240
18,00	0,216	0,198	0,153	0,333	0,270
20,00	0,240	0,220	0,170	0,370	0,300

Gruppe B: faserverstärkte Kunststoffe - AFK - CFK - GFK Group B: reinforced plastic fibres - AFK - CFK - GFK					
B 1.4	Schafffräser mit Spanteiler End mills with chip breaker				
	Eck-/ Konturenfräsen Side-Contour milling		Nutenfräsen Slot milling		
	Schruppen Roughing	Schlichten Finishing			
	$a_p = 1,0 \times D_c$ $a_e = 0,10 \times D_c$	$a_p = 0,75 \times D_c$ $a_e = 0,03 \times D_c$	$a_p = 0,3 \times D_c$		
D_c (mm)	f_z (mm)	f_z (mm)	f_z (mm)		
2,00	0,026	0,024	0,020		
3,00	0,039	0,036	0,030		
4,00	0,052	0,048	0,040		
5,00	0,065	0,060	0,050		
6,00	0,078	0,072	0,060		
8,00	0,104	0,096	0,080		
10,00	0,130	0,120	0,100		
12,00	0,156	0,144	0,120		
14,00	0,182	0,168	0,140		
16,00	0,208	0,192	0,160		
18,00	0,234	0,216	0,180		
20,00	0,260	0,240	0,200		

Schafffräser - Z=1 gerade genutet - WN

"ULTRA Ra" Speed Line mit feingeläppten Spannuten

End mills - Z=1 straight flute - Internal standard

"ULTRA Ra" Speed Line with fine lapped chip flutes

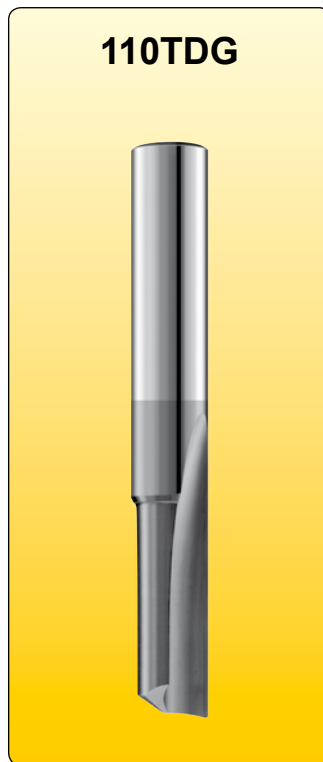
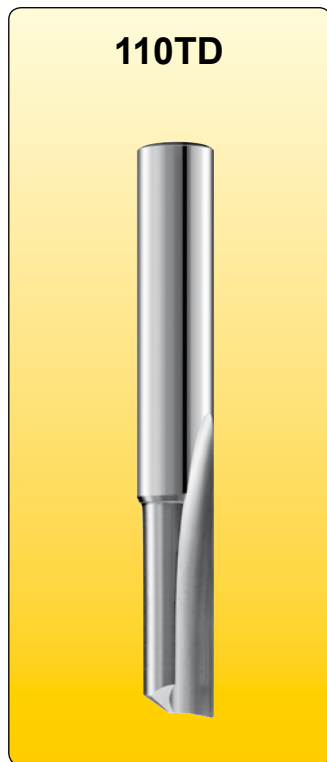

Einsatzgebiete / Range of application

A: Legierungen / Light alloys

A1.1-1.7 A2.1-2.7 A3.1-3.2 A4.1-4.2

B: Kunststoffe - Faserverstärkte Kunststoffe

B: Plastics - Reinforced plastic fibres

B1.1-1.3 B1.5-1.6 B2.1-2.4

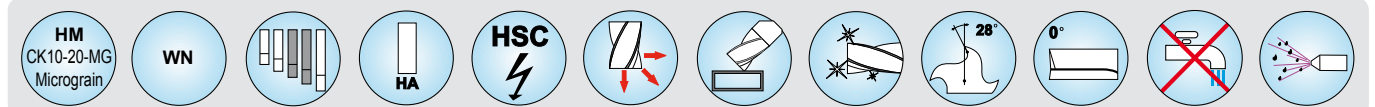
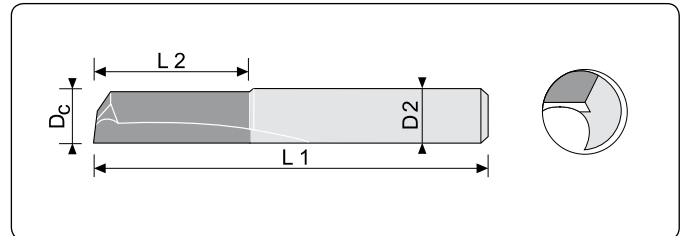

2.
05

D _c h10	L2	L1	D2 h6	110TD	110TDG
					Beschichtet / Coated
1,5	6	40	3	110TD.015030640	110TD.015030640G
2	6	40	3	110TD.020030640	110TD.020030640G
2	10	60	6	110TD.020061060	110TD.020061060G
3	12	40	3	110TD.030031240	110TD.030031240G
3	15	60	6	110TD.030061560	110TD.030061560G
4	15	60	6	110TD.040061560	110TD.040061560G
4	20	75	6	110TD.040062075	110TD.040062075G
5	16	60	6	110TD.050061660	110TD.050061660G
6	20	60	6	110TD.060062060	110TD.060062060G
6	30	60	6	110TD.060063060	110TD.060063060G
6	35	75	6	110TD.060063575	110TD.060063575G
8	22	63	8	110TD.080082263	110TD.080082263G
8	40	100	8	110TD.0800840100	110TD.0800840100G
10	25	72	10	110TD.100102572	110TD.100102572G
10	55	100	10	110TD.1001055100	110TD.1001055100G
12	30	83	12	110TD.120123083	110TD.120123083G

Radius fräser - Z=1 gerade genutet - WN

"ULTRA Ra" Speed Line mit feingeläppten Spannuten

Ball nose cutter - Z=1 straight flute - Internal standard

"ULTRA Ra" Speed Line with fine lapped chip flutes

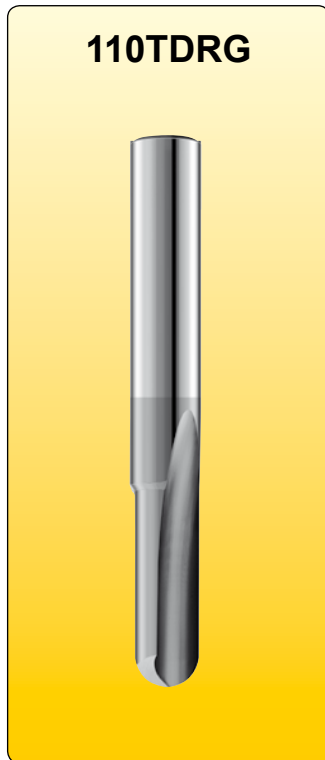
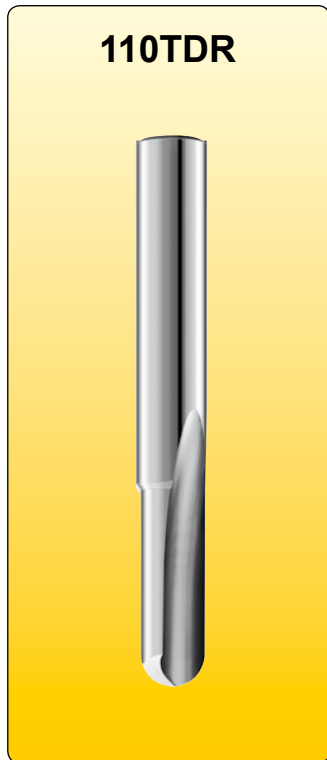

Einsatzgebiete / Range of application

A: Legierungen / Light alloys

A1.1-1.7 A2.1-2.7 A3.1-3.2 A4.1-4.2

B: Kunststoffe - Faserverstärkte Kunststoffe

B: Plastics - Reinforced plastic fibres

B1.1-1.3 B1.5-1.6 B2.1-2.4

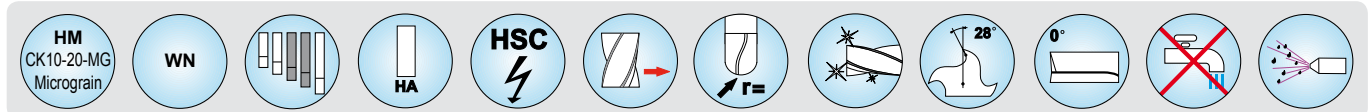
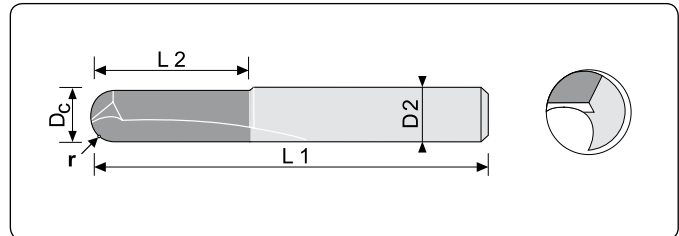

D _c h10	L2	L1	D2 h6	r	110TDR	110TDRG
						Beschichtet / Coated
1,5	6	40	3	0,75	110TDR.015030640	110TDR.015030640G
2	6	40	3	1	110TDR.020030640	110TDR.020030640G
2	10	60	6	1	110TDR.020061060	110TDR.020061060G
3	12	40	3	1,5	110TDR.030031240	110TDR.030031240G
3	15	60	6	1,5	110TDR.030061560	110TDR.030061560G
4	15	60	6	2	110TDR.040061560	110TDR.040061560G
4	20	75	6	2	110TDR.040062075	110TDR.040062075G
5	16	60	6	2,5	110TDR.050061660	110TDR.050061660G
6	20	60	6	3	110TDR.060062060	110TDR.060062060G
6	30	60	6	3	110TDR.060063060	110TDR.060063060G
6	35	75	6	3	110TDR.060063575	110TDR.060063575G
8	22	63	8	4	110TDR.080082263	110TDR.080082263G
8	40	100	8	4	110TDR.0800840100	110TDR.0800840100G
10	25	72	10	5	110TDR.100102572	110TDR.100102572G
10	55	100	10	5	110TDR.1001055100	110TDR.1001055100G
12	30	83	12	6	110TDR.120123083	110TDR.120123083G

Einschneidenfräser Rechtsdrall und Rechtsschneidend für Aluminium

"ULTRA Ra" Speed Line mit feingeläppten Spannuten

Single Flute routers Right hand Spiral - Right hand cut for Aluminium

"ULTRA Ra" Speed Line with fine lapped chip flutes

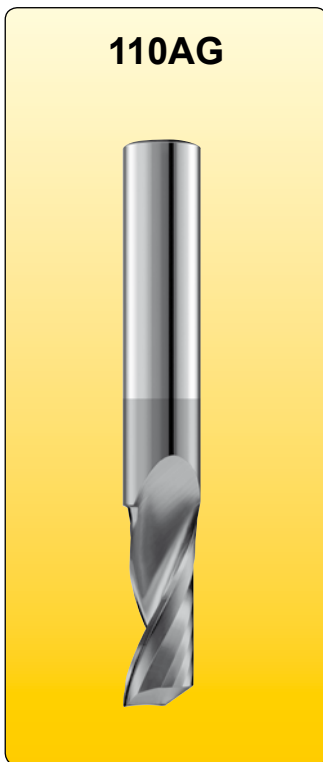
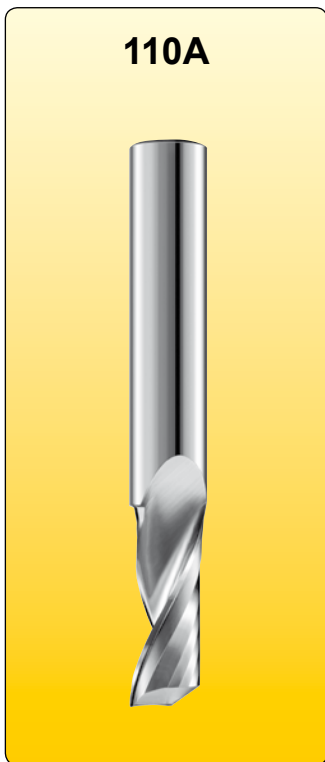

Einsatzgebiete / Range of application

A: Legierungen / Light alloys

A1.1-1.7 A2.1-2.7 A3.1-3.2 A4.1-4.2

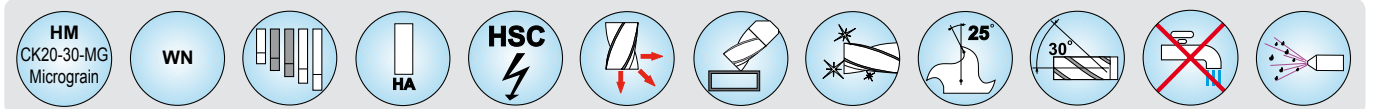
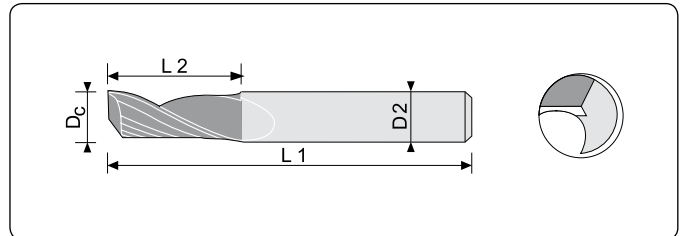

2.
05

D _c h10	L2	L1	D2 h6	110A	110AG
					Beschichtet / Coated
1,5	6	40	3	110A.015030640	110A.015030640G
2	10	40	2	110A.020021040	110A.020021040G
2	8	40	3	110A.020030840	110A.020030840G
2	6	50	6	110A.020060650	110A.020060650G
2,5	8	50	6	110A.025060850	110A.025060850G
3	10	40	3	110A.030031040	110A.030031040G
3	7	50	6	110A.030060750	110A.030060750G
3	10	50	6	110A.030061050	110A.030061050G
3,5	10	50	6	110A.035061050	110A.035061050G
4	12	50	4	110A.040041250	110A.040041250G
4	9	50	6	110A.040060950	110A.040060950G
4	12	50	6	110A.040061250	110A.040061250G
4,5	12	50	6	110A.045061250	110A.045061250G
5	14	50	5	110A.050051450	110A.050051450G
5	11	50	6	110A.050061150	110A.050061150G
5	14	50	6	110A.050061450	110A.050061450G
5,5	14	50	6	110A.055061450	110A.055061450G
6	14	50	6	110A.060061450	110A.060061450G
6	20	60	6	110A.060062060	110A.060062060G
6	35	75	6	110A.060063575	110A.060063575G
8	17	63	8	110A.080081763	110A.080081763G
8	25	63	8	110A.080082563	110A.080082563G
10	25	72	10	110A.100102572	110A.100102572G
12	25	83	12	110A.120122583	110A.120122583G

Einschneidenfräser Linksdrall und Rechtsschneidend für Aluminium

"ULTRA Ra" Speed Line mit feingeläppten Spannuten

Single Flute routers Left hand Spiral - Right hand cut for Aluminium

"ULTRA Ra" Speed Line with fine lapped chip flutes

Einsatzgebiete / Range of application

A: Legierungen / Light alloys

A1.1-1.7 A2.1-2.7 A3.1-3.2 A4.1-4.2

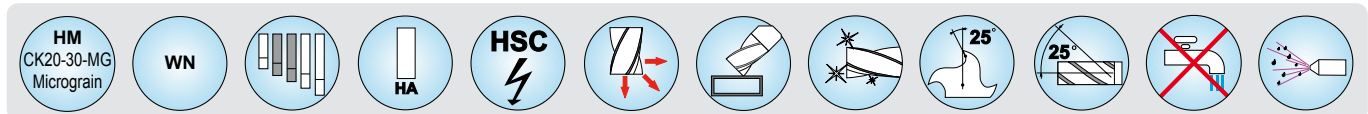
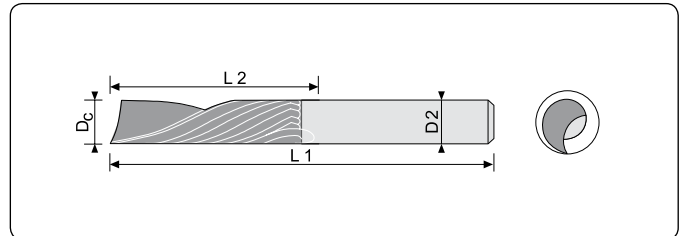
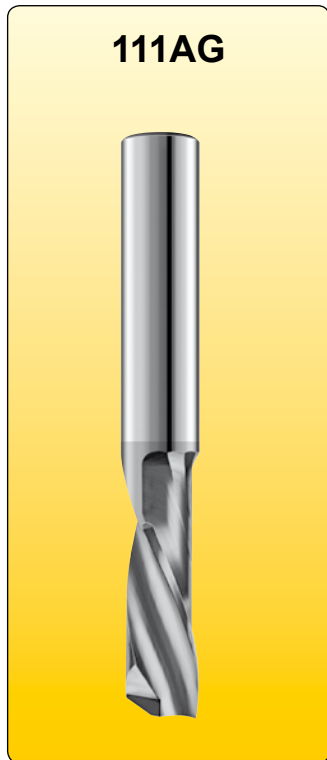
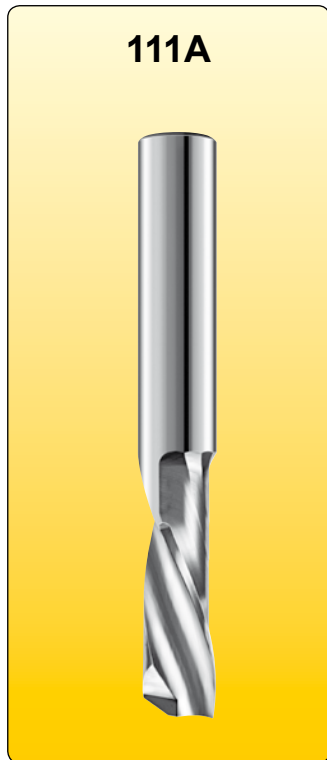

D _c h10	L2	L1	D2 h6	111A	111AG
					Beschichtet / Coated
1,5	6	40	3	111A.015030640	111A.015030640G
2	10	40	2	111A.020021040	111A.020021040G
2	8	40	3	111A.020030840	111A.020030840G
2	6	50	6	111A.020060650	111A.020060650G
2,5	8	50	6	111A.025060850	111A.025060850G
3	10	40	3	111A.030031040	111A.030031040G
3	7	50	6	111A.030060750	111A.030060750G
3	10	50	6	111A.030061050	111A.030061050G
3,5	10	50	6	111A.035061050	111A.035061050G
4	12	50	4	111A.040041250	111A.040041250G
4	9	50	6	111A.040060950	111A.040060950G
4	12	50	6	111A.040061250	111A.040061250G
4,5	12	50	6	111A.045061250	111A.045061250G
5	14	50	5	111A.050051450	111A.050051450G
5	11	50	6	111A.050061150	111A.050061150G
5	14	50	6	111A.050061450	111A.050061450G
5,5	14	50	6	111A.055061450	111A.055061450G
6	14	50	6	111A.060061450	111A.060061450G
6	20	60	6	111A.060062060	111A.060062060G
6	35	75	6	111A.060063575	111A.060063575G
8	17	63	8	111A.080081763	111A.080081763G
8	25	63	8	111A.080082563	111A.080082563G
10	25	72	10	111A.100102572	111A.100102572G
12	25	83	12	111A.120122583	111A.120122583G

2.
05

Einschneidenfräser Rechtsdrall und Rechtsschneidend

"ULTRA Ra" Speed Line mit feingeläppten Spannuten

Single Flute routers Right hand Spiral - Right hand cut

"ULTRA Ra" Speed Line with fine lapped chip flutes

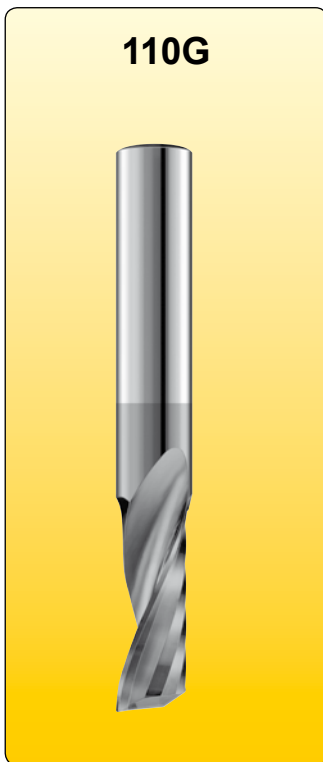

Einsatzgebiete / Range of application

A: Legierungen / Light alloys

A1.1-1.6 A2.1-2.6 A3.1-3.2 A4.1-4.2

B: Kunststoffe - Faserverstärkte Kunststoffe

B: Plastics - Reinforced plastic fibres

B1.1-1.3 B1.5-1.6 B2.1-2.4

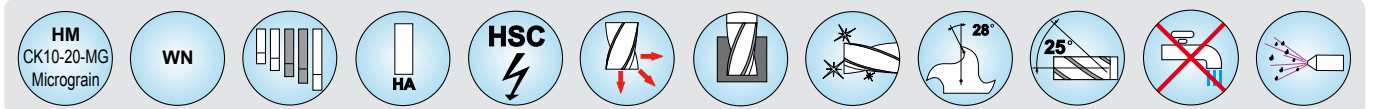
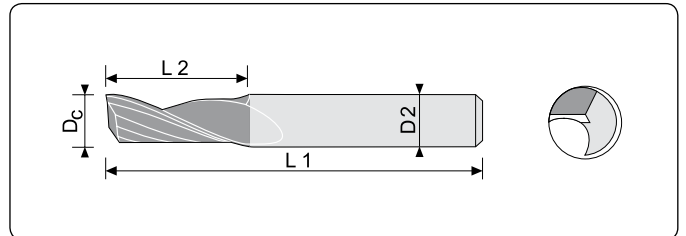

2.05

D _c h10	L2	L1	D2 h6	110	110G
					Beschichtet / Coated
1,5	6	40	3	110.015030640	110.015030640G
2	6	40	3	110.020030640	110.020030640G
2	10	40	2	110.020021040	110.020021040G
2	5	50	6	110.020060550	110.020060550G
2	10	60	6	110.020061060	110.020061060G
2,5	6	40	2,5	110.025250640	110.025250640G
3	12	40	3	110.030031240	110.030031240G
3	7	50	6	110.030060750	110.030060750G
3	10	60	6	110.030061060	110.030061060G
3	12	60	6	110.030061260	110.030061260G
3	15	60	6	110.030061560	110.030061560G
4	15	40	4	110.040041540	110.040041540G
4	9	50	6	110.040060950	110.040060950G
4	12	60	6	110.040061260	110.040061260G
4	15	60	6	110.040061560	110.040061560G
4	20	75	6	110.040062075	110.040062075G
5	11	50	6	110.050061150	110.050061150G
5	16	50	5	110.050051650	110.050051650G
5	16	60	6	110.050061660	110.050061660G
5	28	75	6	110.050062875	110.050062875G
6	13	50	6	110.060061350	110.060061350G
6	20	60	6	110.060062060	110.060062060G

D _c h10	L2	L1	D2 h6	110	110G
					Beschichtet / Coated
6	22	60	6	110.060062260	110.060062260G
6	30	60	6	110.060063060	110.060063060G
6	35	75	6	110.060063575	110.060063575G
8	17	63	8	110.080081763	110.080081763G
8	22	63	8	110.080082263	110.080082263G
8	35	75	8	110.080083575	110.080083575G
8	45	100	8	110.0800845100	110.0800845100G
10	25	72	10	110.100102572	110.100102572G
10	35	80	10	110.100103580	110.100103580G
10	55	100	10	110.1001055100	110.1001055100G
12	30	83	12	110.120123083	110.120123083G
12	55	110	12	110.1201255110	110.1201255110G
14	30	83	14	110.140143083	110.140143083G
16	35	92	16	110.160163592	110.160163592G
16	70	125	16	110.1601670125	110.1601670125G
20	40	104	20	110.2002040104	110.2002040104G
20	60	125	20	110.2002060125	110.2002060125G

Einschneidenfräser Linksdreht und Rechtsschneidend

"ULTRA Ra" Speed Line mit feingeläppten Spannuten

Single Flute routers Left hand Spiral - Right hand cut

"ULTRA Ra" Speed Line with fine lapped chip flutes



Einsatzgebiete / Range of application

A: Legierungen / Light alloys

A1.1-1.6 A2.1-2.6 A3.1-3.2 A4.1-4.2

B: Kunststoffe - Faserverstärkte Kunststoffe

B: Plastics - Reinforced plastic fibres

B1.1-1.3 B1.5-1.6 B2.1-2.4

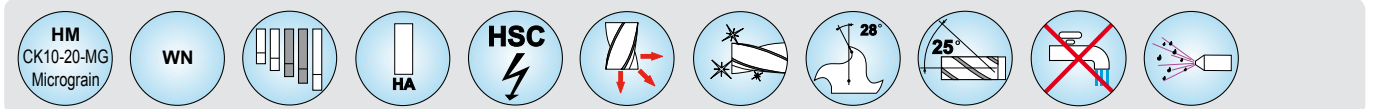
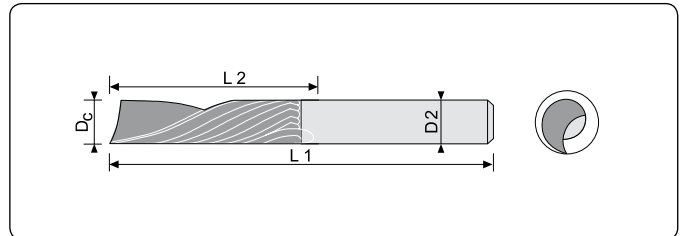

2.
05

D _c h10	L2	L1	D2 h6	111	111G
					Beschichtet / Coated
1,5	6	40	3	111.015030640	111.015030640G
2	6	40	3	111.020030640	111.020030640G
2	10	40	2	111.020021040	111.020021040G
2	5	50	6	111.020060550	111.020060550G
2	10	60	6	111.020061060	111.020061060G
2,5	6	40	2,5	111.025250640	111.025250640G
3	12	40	3	111.030031240	111.030031240G
3	7	50	6	111.030060750	111.030060750G
3	10	60	6	111.030061060	111.030061060G
3	12	60	6	111.030061260	111.030061260G
3	15	60	6	111.030061560	111.030061560G
4	15	40	4	111.040041540	111.040041540G
4	9	50	6	111.040060950	111.040060950G
4	12	60	6	111.040061260	111.040061260G
4	15	60	6	111.040061560	111.040061560G
4	20	75	6	111.040062075	111.040062075G
5	11	50	6	111.050061150	111.050061150G
5	16	50	5	111.050051650	111.050051650G
5	16	60	6	111.050061660	111.050061660G
5	28	75	6	111.050062875	111.050062875G
6	13	50	6	111.060061350	111.060061350G
6	20	60	6	111.060062060	111.060062060G

D _c h10	L2	L1	D2 h6	111	111G
					Beschichtet / Coated
6	22	60	6	111.060062260	111.060062260G
6	30	60	6	111.060063060	111.060063060G
6	35	75	6	111.060063575	111.060063575G
8	17	63	8	111.080081763	111.080081763G
8	22	63	8	111.080082263	111.080082263G
8	35	75	8	111.080083575	111.080083575G
8	45	100	8	111.0800845100	111.0800845100G
10	25	72	10	111.100102572	111.100102572G
12	30	83	12	111.120123083	111.120123083G
14	30	83	14	111.140143083	111.140143083G
16	35	92	16	111.160163592	111.160163592G
20	40	104	20	111.2002040104	111.2002040104G

Radius Einschneidenfräser Rechtsdrill und Rechtsschneidend

"ULTRA Ra" Speed Line mit feingeläppten Spannuten

Radius Single Flute routers Right hand Spiral - Right hand cut

"ULTRA Ra" Speed Line with fine lapped chip flutes

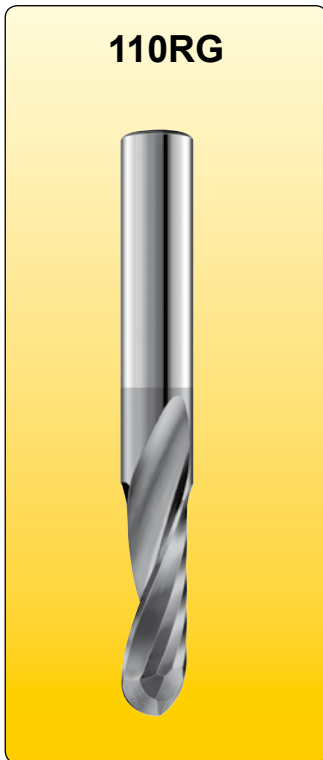
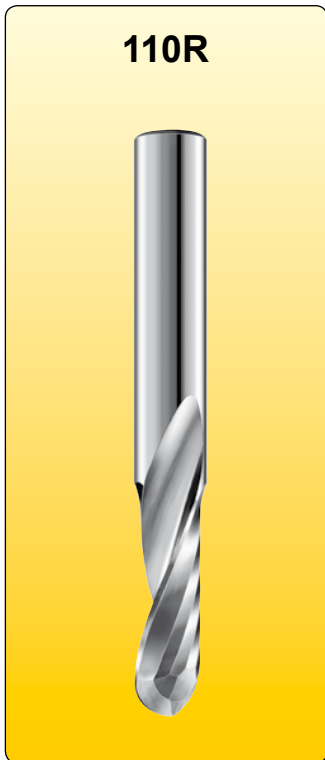

Einsatzgebiete / Range of application

A: Legierungen / Light alloys

A1.1-1.6 A2.1-2.6 A3.1-3.2 A4.1-4.2

B: Kunststoffe - Faserverstärkte Kunststoffe

B: Plastics - Reinforced plastic fibres

B1.1-1.3 B1.5-1.6 B2.1-2.4

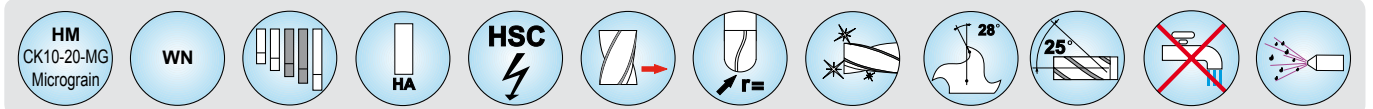
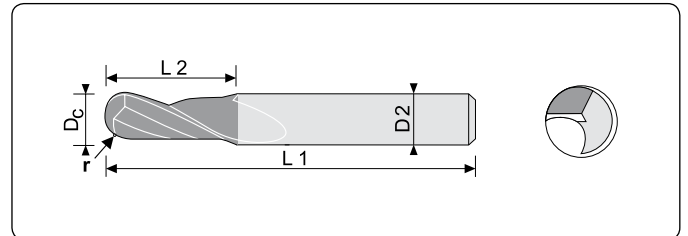

2.
05

D _c h10	L2	L1	D2 h6	r	110R	110RG
						Beschichtet / Coated
2	6	40	3	1	110R.020030640	110R.020030640G
2	10	60	6	1	110R.020061060	110R.020061060G
3	12	40	3	1,5	110R.030031240	110R.030031240G
3	12	60	6	1,5	110R.030061260	110R.030061260G
4	15	40	4	2	110R.040041540	110R.040041540G
4	15	60	6	2	110R.040061560	110R.040061560G
5	16	60	6	2,5	110R.050061660	110R.050061660G
5	16	50	5	2,5	110R.050051650	110R.050051650G
6	20	60	6	3	110R.060062060	110R.060062060G
6	30	60	6	3	110R.060063060	110R.060063060G
6	35	75	6	3	110R.060063575	110R.060063575G
8	22	63	8	4	110R.080082263	110R.080082263G
8	40	100	8	4	110R.0800840100	110R.0800840100G
10	25	72	10	5	110R.100102572	110R.100102572G
10	55	100	10	5	110R.1001055100	110R.1001055100G
12	30	83	12	6	110R.120123083	110R.120123083G

Schaftfräser - Z=2 gerade genutet - WN

"ULTRA Ra" Speed Line mit feingeläppten Spannuten

End mills - Z=2 straight flute - Internal standard

"ULTRA Ra" Speed Line with fine lapped chip flutes

Einsatzgebiete / Range of application

A: Legierungen / Light alloys

A1.1-1.7 A2.1-2.7 A3.1-3.2 A4.1-4.2

B: Kunststoffe - Faserverstärkte Kunststoffe

B: Plastics - Reinforced plastic fibres

B1.1-1.3 B1.5-1.6 B2.1-2.4

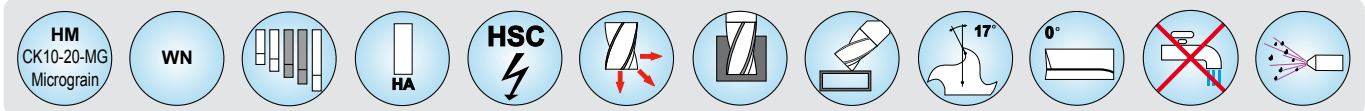
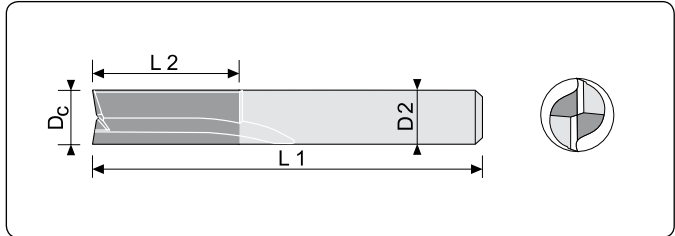

D _c h10	L2	L1	D2 h6	100	100G
					Beschichtet / Coated
3	12	40	3	100.030031240	100.030031240G
3	12	50	6	100.030061250	100.030061250G
4	14	40	4	100.040041440	100.040041440G
4	14	50	6	100.040061450	100.040061450G
5	16	50	5	100.050051650	100.050051650G
6	18	50	6	100.060061850	100.060061850G
8	20	63	8	100.080082063	100.080082063G
10	25	72	10	100.100102572	100.100102572G
12	30	83	12	100.120123083	100.120123083G
16	35	92	16	100.160163592	100.160163592G
20	45	104	20	100.2002045104	100.2002045104G

2.
05

Schafffräser - Z=2 Drall 30° - WN

"ULTRA Ra" Speed Line mit feingeläppten Spannuten - doppeltem Spanwinkel - konische Seele

End mills - Z=2 Helix 30° - Internal standard

"ULTRA Ra" Speed Line with fine lapped chip flutes-with double rake angle - conical core

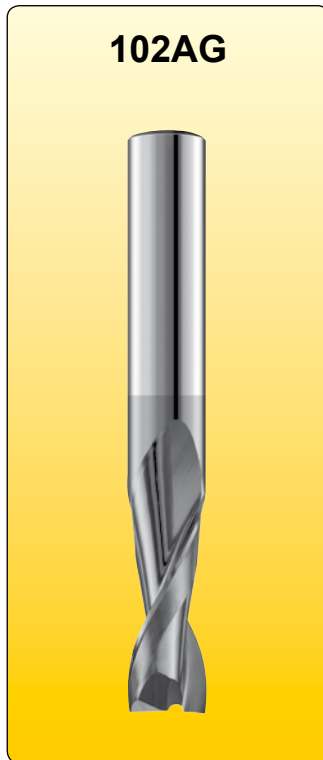

Einsatzgebiete / Range of application

A: Legierungen / Light alloys
A1.1-1.7 A2.1-2.7 A3.1-3.2 A4.1-4.2

E: Titan / Titanium
E1.1

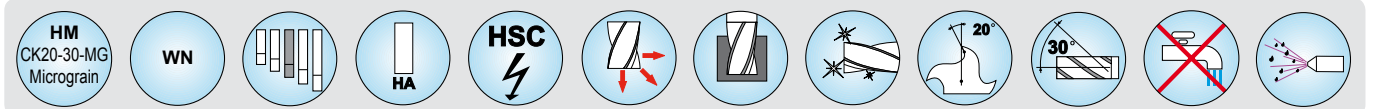
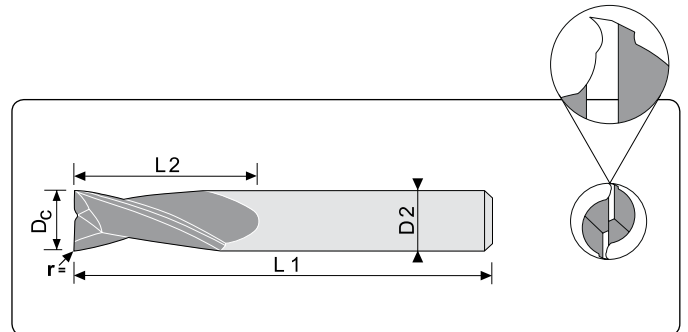

2.
05

D _c h10	L2	L1	D2 h6	102A	102AG
					Beschichtet / Coated
3	12	50	6	102A.030061250	102A.030061250G
4	14	50	6	102A.040061450	102A.040061450G
6	18	50	6	102A.060061850	102A.060061850G
8	20	63	8	102A.080082063	102A.080082063G
10	25	72	10	102A.100102572	102A.100102572G
12	30	83	12	102A.120123083	102A.120123083G
16	35	92	16	102A.160163592	102A.160163592G
20	45	104	20	102A.2002045104	102A.2002045104G

Schaftfräser - Z=2 Drall 30° - WN

"ULTRA Ra" Speed Line mit feingeläppten Spannuten

End mills - Z=2 Helix 30° - Internal standard

"ULTRA Ra" Speed Line with fine lapped chip flutes

Einsatzgebiete / Range of application

A: Legierungen / Light alloys

A1.1-1.7 A2.1-2.7 A3.1-3.2 A4.1-4.2

B: Kunststoffe

 B: *Plastics*

B1.1-1.3 B1.5-1.6 B2.1-2.4

E: Titan / Titanium

E1.1

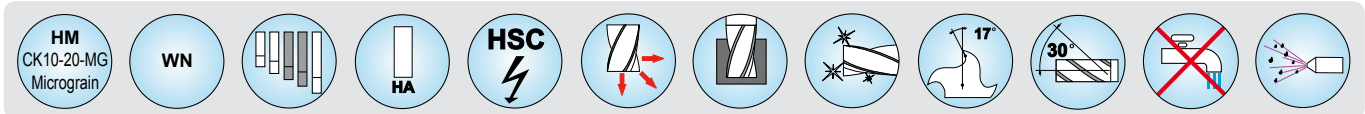
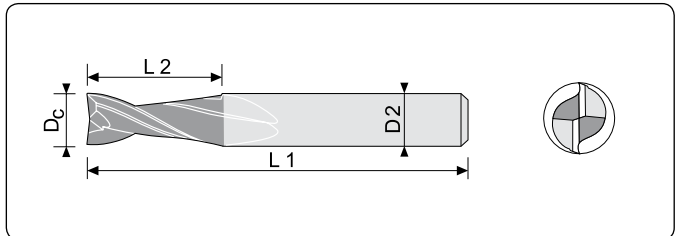
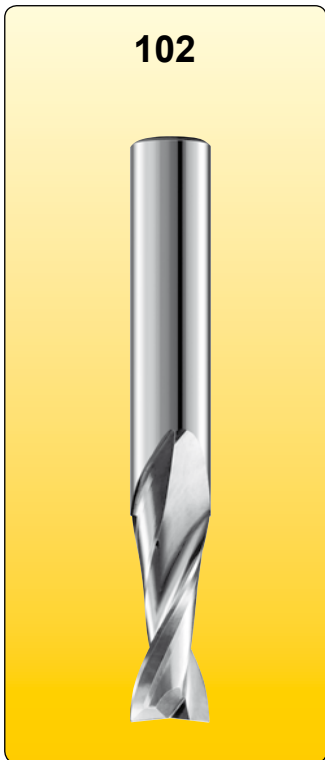

D _c h10	L2	L1	D2 h6	102	102G
					Beschichtet / Coated
2	6	50	6	102.020060650	102.020060650G
2	8	50	3	102.020030850	102.020030850G
3	12	40	3	102.030031240	102.030031240G
3	7	50	6	102.030060750	102.030060750G
3	12	50	6	102.030061250	102.030061250G
4	14	40	4	102.040041440	102.040041440G
4	9	50	6	102.040060950	102.040060950G
4	14	50	6	102.040061450	102.040061450G
5	11	50	6	102.050061150	102.050061150G
5	16	50	5	102.050051650	102.050051650G
6	13	50	6	102.060061350	102.060061350G
6	18	50	6	102.060061850	102.060061850G
6	25	60	6	102.060062560	102.060062560G
6	35	75	6	102.060063575	102.060063575G
8	20	63	8	102.080082063	102.080082063G
8	30	75	8	102.080083075	102.080083075G
8	40	100	8	102.0800840100	102.0800840100G
10	25	72	10	102.100102572	102.100102572G
12	30	83	12	102.120123083	102.120123083G
16	35	92	16	102.160163592	102.160163592G
20	45	104	20	102.2002045104	102.2002045104G

**2.
05**

Schafffräser - Z=2 Linksdrall-rechtsschneidend - WN

"ULTRA Ra" Speed Line mit feingeläppten Spannuten

End mills - Z=2 Left hand spiral - Right hand cut - Internal standard

"ULTRA Ra" Speed Line with fine lapped chip flutes

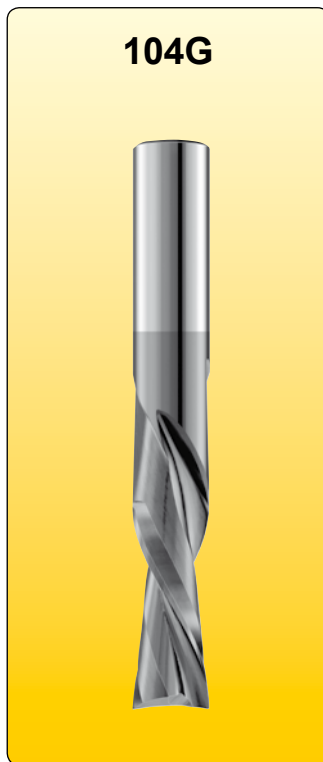

Einsatzgebiete / Range of application

A: Legierungen / Light alloys
A1.1-1.7 A2.1-2.7 A3.1-3.2 A4.1-4.2

B: Kunststoffe
B: Plastics
B1.1-1.3 B1.5-1.6 B2.1-2.4

E: Titan / Titanium
E1.1

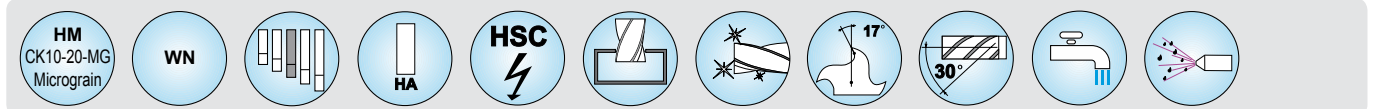
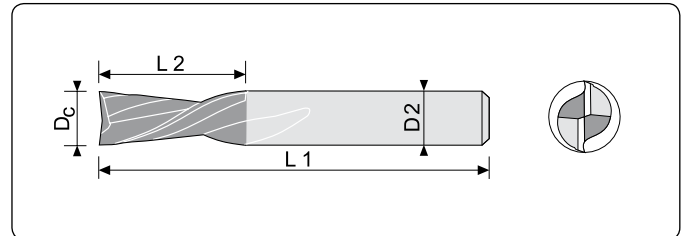

2.
05

D _c h10	L2	L1	D2 h6	104	104G
					Beschichtet / Coated
2	6	50	6	104.020060650	104.020060650G
3	12	40	3	104.030031240	104.030031240G
3	9	50	6	104.030060950	104.030060950G
3	12	50	6	104.030061250	104.030061250G
4	14	40	4	104.040041440	104.040041440G
4	13	50	6	104.040061350	104.040061350G
5	16	50	5	104.050051650	104.050051650G
6	18	50	6	104.060061850	104.060061850G
8	20	63	8	104.080082063	104.080082063G
10	25	72	10	104.100102572	104.100102572G
12	30	83	12	104.120123083	104.120123083G
16	35	92	16	104.160163592	104.160163592G
20	45	104	20	104.2002045104	104.2002045104G

Schaftfräser - Z=2 Drall 45° - WN

"ULTRA Ra" Speed Line mit feingeläppten Spannuten

End mills - Z=2 Helix 45° - Internal standard

"ULTRA Ra" Speed Line with fine lapped chip flutes

Einsatzgebiete / Range of application

A: Legierungen / Light alloys

A1.1-1.7 A2.1-2.7 A3.1-3.2 A4.1-4.2

B: Kunststoffe

B: Plastics

B1.1-1.3 B1.5-1.6 B2.1-2.4

Titan / Titanium

E1.1

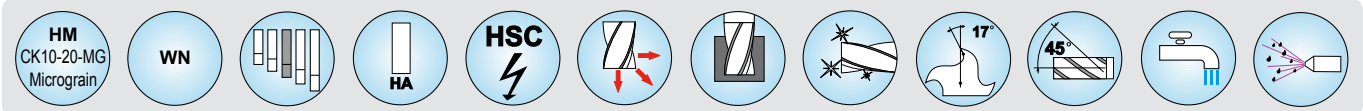
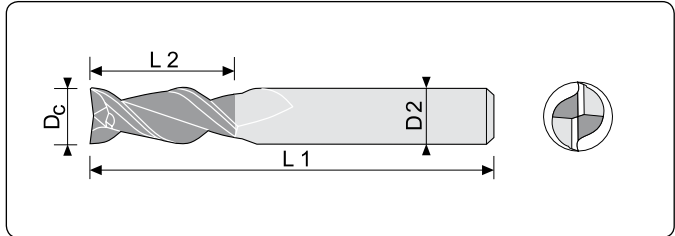
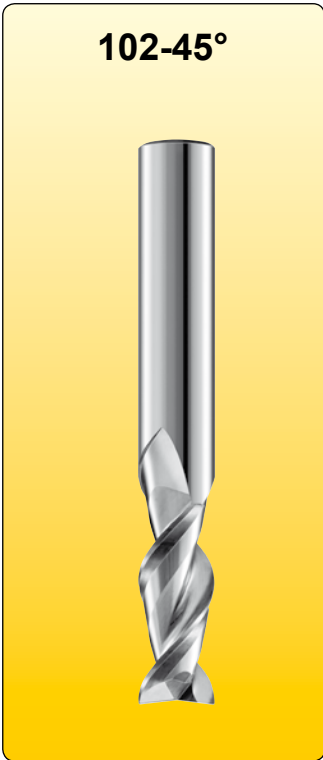

D _c h10	L2	L1	D2 h6	102-45°	102-45°G
					Beschichtet / Coated
2	8	50	3	102.020030850-45°	102.020030850G-45°G
3	12	40	3	102.030031240-45°	102.030031240G-45°G
3	12	50	6	102.030061250-45°	102.030061250G-45°G
4	14	40	4	102.040041440-45°	102.040041440G-45°G
4	14	50	6	102.040061450-45°	102.040061450G-45°G
5	11	50	6	102.050061150-45°	102.050061150G-45°G
5	16	50	6	102.050061650-45°	102.050061650G-45°G
6	18	50	6	102.060061850-45°	102.060061850G-45°G
6	25	60	6	102.060062560-45°	102.060062560G-45°G
6	35	75	6	102.060063575-45°	102.060063575G-45°G
8	20	63	8	102.080082063-45°	102.080082063G-45°G
8	30	75	8	102.080083075-45°	102.080083075G-45°G
8	40	100	8	102.0800840100-45°	102.0800840100G-45°G
10	25	72	10	102.100102572-45°	102.100102572G-45°G
12	30	83	12	102.120123083-45°	102.120123083G-45°G
16	35	92	16	102.160163592-45°	102.160163592G-45°G
20	45	104	20	102.2002045104-45°	102.2002045104G-45°G

**2.
05**

Schafffräser - Z=3 gerade genutet - WN

"ULTRA Ra" Speed Line mit feingeläppten Spannuten

End mills - Z=3 straight flute - Internal standard

"ULTRA Ra" Speed Line with fine lapped chip flutes

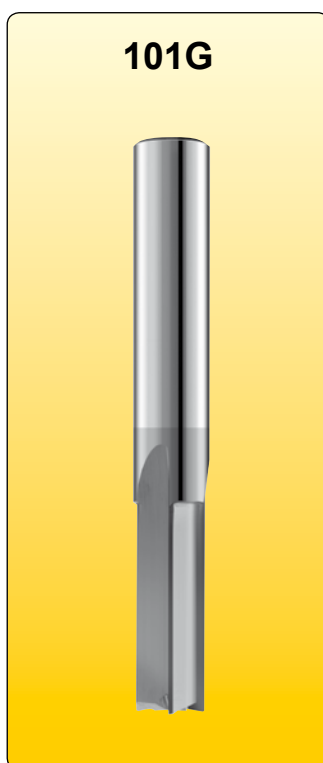
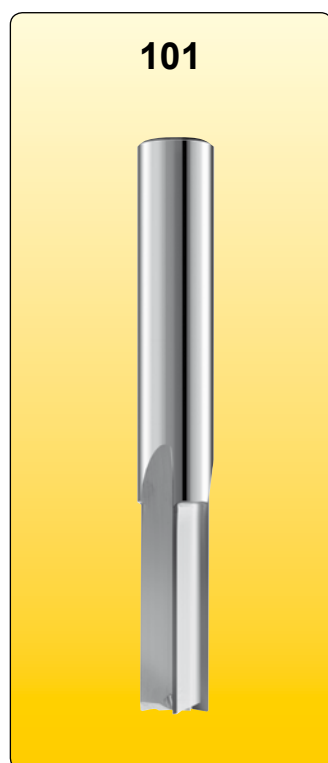

Einsatzgebiete / Range of application

A: Legierungen / Light alloys
A1.1-1.7 A2.1-2.7 A3.1-3.2 A4.1-4.2

B: Kunststoffe
B: Plastics
B1.1-1.3 B1.5-1.6 B2.1-2.4

Titan / Titanium
E1.1

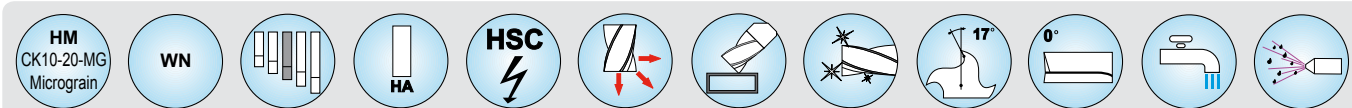
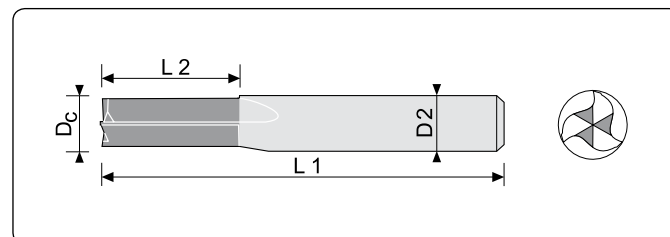

2.05

D _c h10	L2	L1	D2 h6	101	101G
					Beschichtet / Coated
3	12	40	3	101.030031240	101.030031240G
4	14	40	4	101.040041440	101.040041440G
5	16	50	5	101.050051650	101.050051650G
6	18	50	6	101.060061850	101.060061850G
8	20	63	8	101.080082063	101.080082063G
10	25	72	10	101.100102572	101.100102572G
12	30	83	12	101.120123083	101.120123083G
16	35	92	16	101.160163592	101.160163592G
20	45	104	20	101.2002045104	101.2002045104G

Schaftfräser - Drall 45° - ähnlich DIN 6527-L - Für Plexiglass Ultra-läppen

"PIRAÑA" ungleiche Schneidenteilung - feingeläppte Spannuten

End mills - Helix 45° - Similar to DIN 6527-L - for super-finishing of Plexiglass

"PIRAÑA"uneven division of cutting edges - fine lapped chip flutes

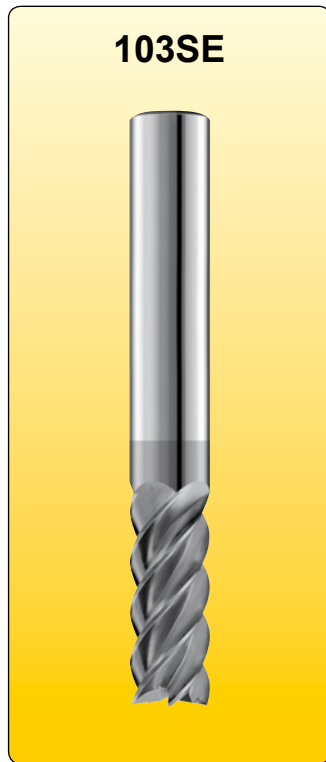
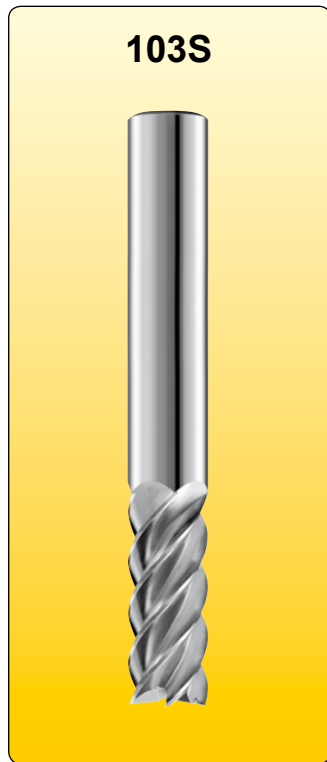

Einsatzgebiete / Range of application

A: Legierungen / Light alloys
A1.1-1.6 A2.1-2.6 A3.1-3.2 A4.1-4.2

B: Kunststoffe - Faserverstärkte Kunststoffe
B: Plastics - Reinforced plastic fibres
B1.1-1.3 B1.5-1.6 B2.1-2.4

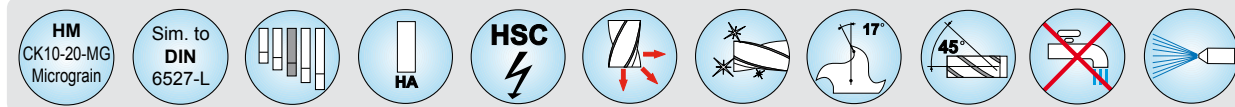
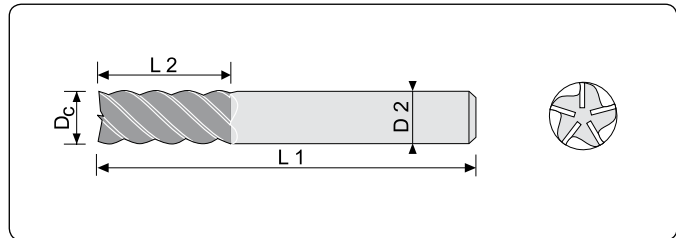

D _c h10	L2	L1	D2 h6	103S	103SE
					Beschichtet / Coated
3	10	57	6	103S.030061057	103S.030061057E
4	15	57	6	103S.040061557	103S.040061557E
5	20	57	6	103S.050062057	103S.050062057E
6	20	57	6	103S.060062057	103S.060062057E
8	25	63	8	103S.080082563	103S.080082563E
10	25	72	10	103S.100102572	103S.100102572E
12	30	83	12	103S.120123083	103S.120123083E

Schafffräser - Z=3 Drall 30° - Linksdrall-rechtsschneidend - WN

"ULTRA Ra" Speed Line mit feingeläppten Spannuten

End mills - Z=3 Helix 30° - Left hand spiral - Right hand cut - Internal standard

"ULTRA Ra" Speed Line with fine lapped chip flutes

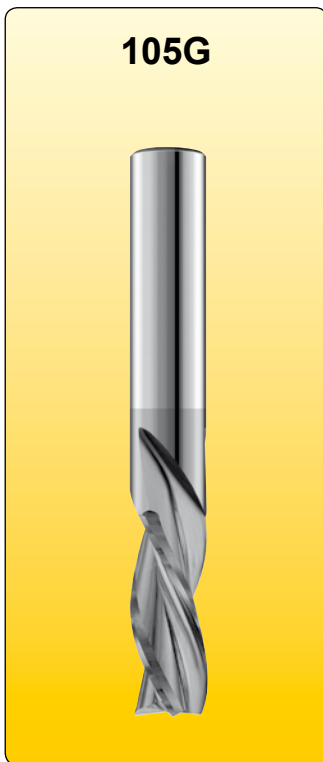
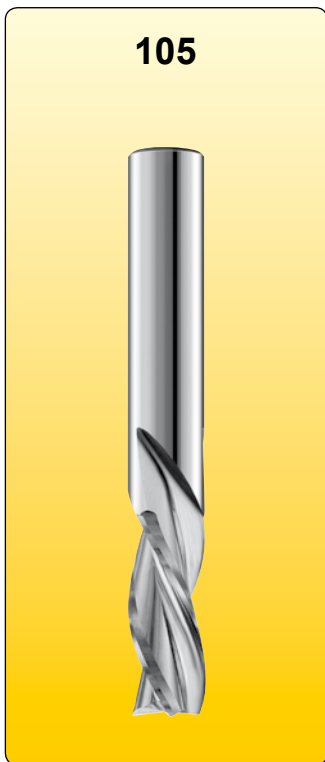

Einsatzgebiete / Range of application

A: Legierungen / Light alloys

A1.1-1.7 A2.1-2.7 A3.1-3.2 A4.1-4.2

B: Kunststoffe - Faserverstärkte Kunststoffe

B: Plastics - Reinforced plastic fibres

B1.1-1.3 B1.5-1.6 B2.1-2.4

Titan / Titanium

E1.1

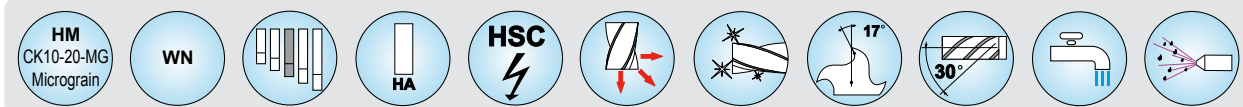
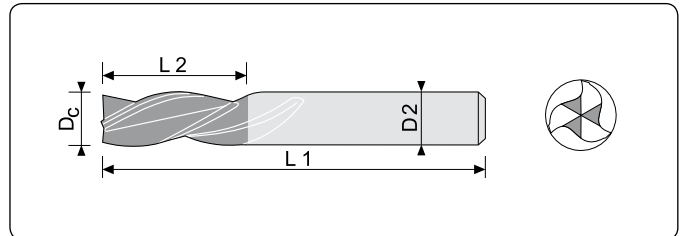

2.
05

D _c h10	L2	L1	D2 h6	105	105G
					Beschichtet / Coated
3	12	40	3	105.030031240	105.030031240G
4	14	40	4	105.040041440	105.040041440G
5	16	50	5	105.050051650	105.050051650G
6	18	50	6	105.060061850	105.060061850G
8	20	63	8	105.080082063	105.080082063G
10	25	72	10	105.100102572	105.100102572G
12	30	83	12	105.120123083	105.120123083G
16	35	92	16	105.160163592	105.160163592G
20	45	104	20	105.2002045104	105.2002045104G

Schaftfräser - Z=3 Drall 30° - Ähnlich DIN 6527-L

"PIRAÑA" ungleiche Schneidenteilung - feingeläppte Spannuten

End mills - Z=3 Helix 30° - Similar to DIN 6527-L

"PIRAÑA" uneven division of cutting edges - fine lapped chip flutes

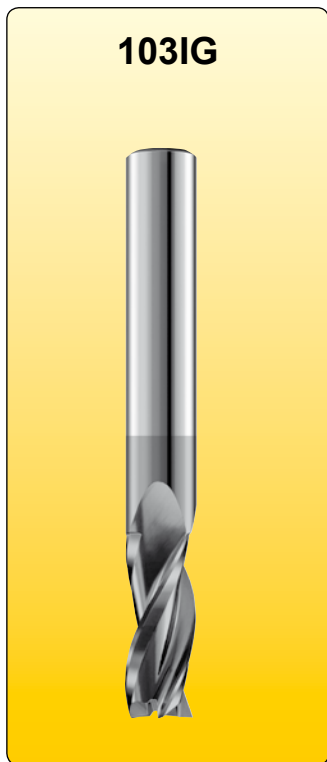
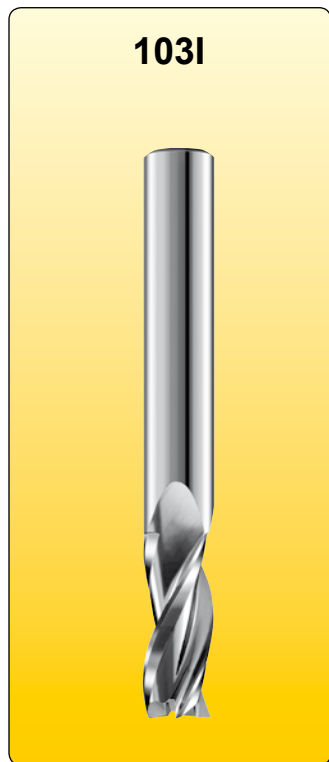
Einsatzgebiete / Range of application
A: Legierungen / Light alloys

A1.1-1.7 A2.1-2.7 A3.1-3.2 A4.1-4.2

B: Kunststoffe - Faserverstärkte Kunststoffe
B: Plastics - Reinforced plastic fibres

B1.1-1.3 B1.5-1.6 B2.1-2.4

Titan / Titanium

E1.1

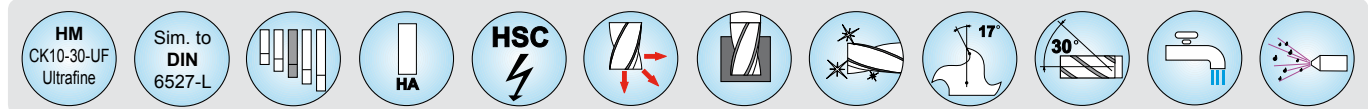
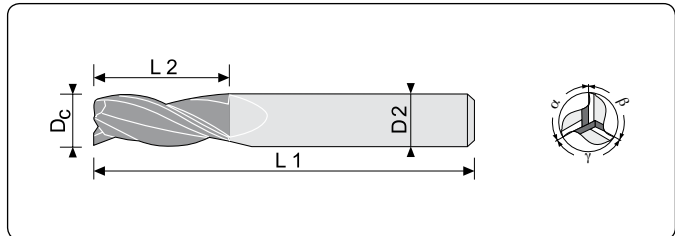

D _c h10	L2	L1	D2 h6	1031	103IG
					Beschichtet / Coated
3	10	57	6	1031.030061057	1031.030061057G
4	13	57	6	1031.040061357	1031.040061357G
5	15	57	6	1031.050061557	1031.050061557G
6	18	57	6	1031.060061857	1031.060061857G
7	20	63	8	1031.070082063	1031.070082063G
8	20	63	8	1031.080082063	1031.080082063G
9	22	72	10	1031.090102272	1031.090102272G
10	25	72	10	1031.100102572	1031.100102572G
12	30	83	12	1031.120123083	1031.120123083G
14	30	83	14	1031.140143083	1031.140143083G
16	35	92	16	1031.160163592	1031.160163592G
18	35	92	18	1031.180183592	1031.180183592G
20	45	104	20	1031.2002045104	1031.2002045104G

Torusfräser - Z=3 Drall 30° - Ähnlich DIN 6527-L

"PIRAÑA" ungleiche Schneidenteilung - feingeläppte Spannuten

Torus cutters - Z=3 Helix 30° - Similar to DIN 6527-L

"PIRAÑA" uneven division of cutting edges - fine lapped chip flutes

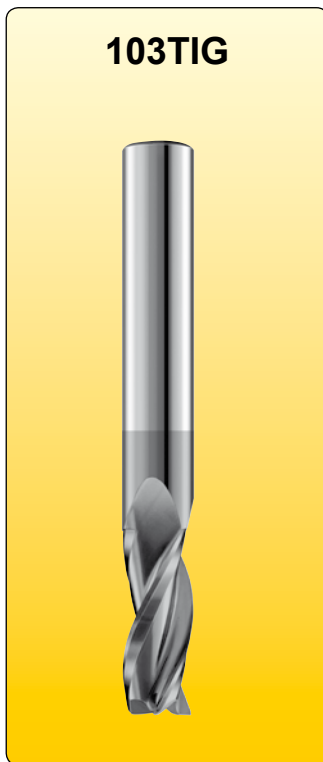
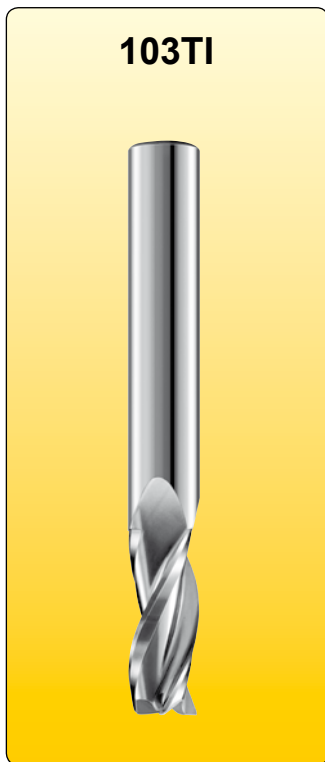

Einsatzgebiete / Range of application

A: Legierungen / Light alloys

A1.1-1.7 A2.1-2.7 A3.1-3.2 A4.1-4.2

B: Kunststoffe - Faserverstärkte Kunststoffe

B: Plastics - Reinforced plastic fibres

B1.1-1.3 B1.5-1.6 B2.1-2.4

Titan / Titanium

E1.1

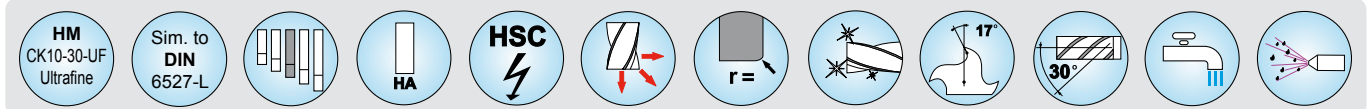
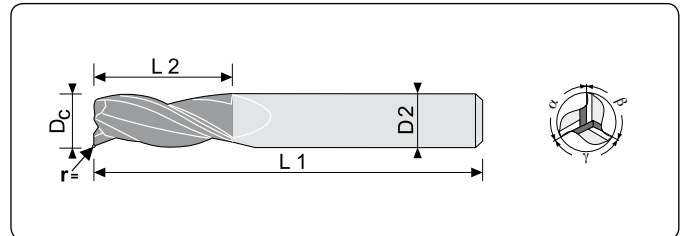

2.
05

D _c h10	L2	L1	D2 h6	r mm	103TI	103TIG
						Beschichtet / Coated
3	10	57	6	0,5	103TI.030061057	103TI.030061057G
4	13	57	6	0,5	103TI.040061357	103TI.040061357G
5	15	57	6	0,5	103TI.050061557	103TI.050061557G
6	18	57	6	1	103TI.060061857	103TI.060061857G
7	20	63	8	1	103TI.070082063	103TI.070082063G
8	20	63	8	1	103TI.080082063	103TI.080082063G
9	22	72	10	1	103TI.090102272	103TI.090102272G
10	25	72	10	1,5	103TI.100102572	103TI.100102572G
12	30	83	12	1,5	103TI.120123083	103TI.120123083G
14	30	83	14	2	103TI.140143083	103TI.140143083G
16	35	92	16	2	103TI.160163592	103TI.160163592G
18	35	92	18	2	103TI.180183592	103TI.180183592G
20	45	104	20	2,5	103TI.2002045104	103TI.2002045104G

Schaftfräser - Z=3 Drall 45° - Ähnlich DIN 6527-L
 "PIRAÑA" ungleiche Schneidenteilung - feingeläppte Spannuten
End mills - Z=3 Helix 45° - Similar to DIN 6527-L
 "PIRAÑA" uneven division of cutting edges - fine lapped chip flutes

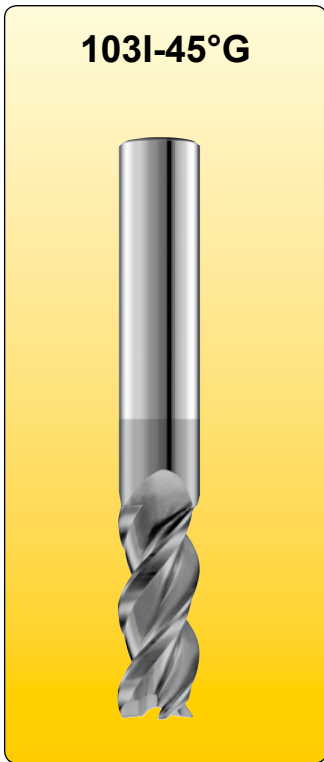

Einsatzgebiete / Range of application

- A: Legierungen / Light alloys**
A1.1-1.7 A2.1-2.7 A3.1-3.2 A4.1-4.2
- B: Kunststoffe - Faserverstärkte Kunststoffe**
B: Plastics - Reinforced plastic fibres
B1.1-1.3 B1.5-1.6 B2.1-2.4
- E: Titan / Titanium**
E1.1

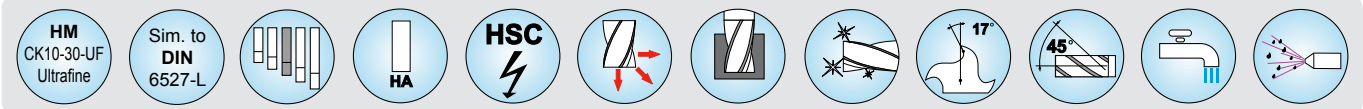
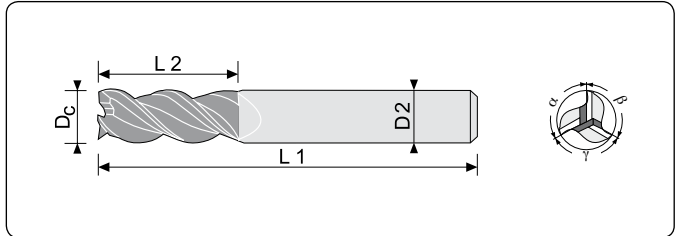

D _c h10	L2	L1	D2 h6	1031-45°	1031-45°G
					Beschichtet / Coated
3	10	57	6	1031.030061057-45°	1031.030061057-45°G
4	13	57	6	1031.040061357-45°	1031.040061357-45°G
5	15	57	6	1031.050061557-45°	1031.050061557-45°G
6	18	57	6	1031.060061857-45°	1031.060061857-45°G
7	20	63	8	1031.070082063-45°	1031.070082063-45°G
8	20	63	8	1031.080082063-45°	1031.080082063-45°G
9	22	72	10	1031.090102272-45°	1031.090102272-45°G
10	25	72	10	1031.100102572-45°	1031.100102572-45°G
12	30	83	12	1031.120123083-45°	1031.120123083-45°G
14	30	83	14	1031.140143083-45°	1031.140143083-45°G
16	35	92	16	1031.160163592-45°	1031.160163592-45°G
18	35	92	18	1031.180183592-45°	1031.180183592-45°G
20	45	104	20	1031.2002045104-45°	1031.2002045104-45°G

**2.
05**

Radiusfräser - Z=3 Drall 30° - Ähnlich DIN 6527-L

"PIRAÑA" ungleiche Schneidenteilung - feingeläppte Spannuten

Ball nose cutters - Z=3 Helix 30° - Similar to DIN 6527-L

"PIRAÑA" uneven division of cutting edges - fine lapped chip flutes

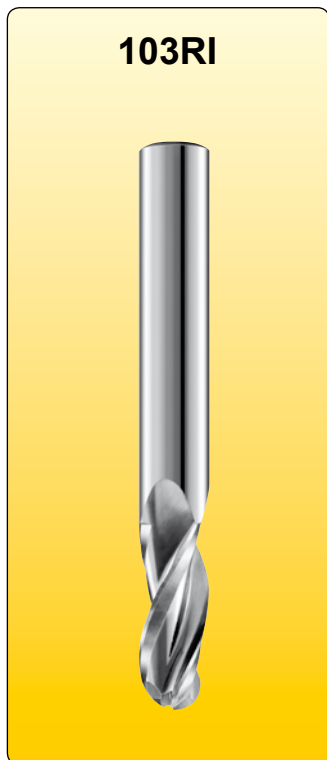

Einsatzgebiete / Range of application

A: Legierungen / Light alloys

A1.1-1.7 A2.1-2.7 A3.1-3.2 A4.1-4.2

B: Kunststoffe - Faserverstärkte Kunststoffe

B: Plastics - Reinforced plastic fibres

B1.1-1.3 B1.5-1.6 B2.1-2.4

Titan / Titanium

E1.1

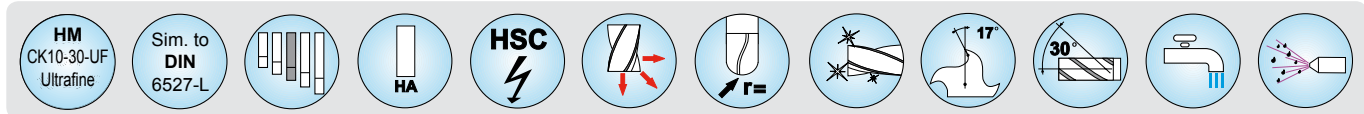
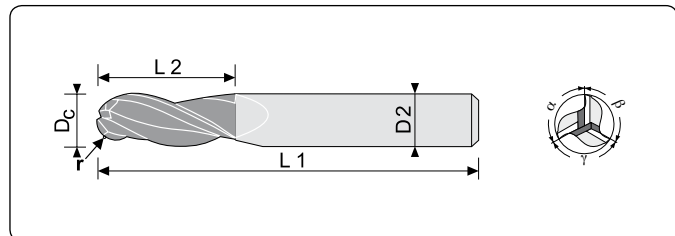

2.
05

D _c h10	L2	L1	D2 h6	r mm	103RI	103RIG
						Beschichtet / Coated
3	10	57	6	1,5	103RI.030061057	103RI.030061057G
4	13	57	6	2	103RI.040061357	103RI.040061357G
5	15	57	6	2,5	103RI.050061557	103RI.050061557G
6	18	57	6	3	103RI.060061857	103RI.060061857G
7	20	63	8	3,5	103RI.070082063	103RI.070082063G
8	20	63	8	4	103RI.080082063	103RI.080082063G
9	22	72	10	4,5	103RI.090102272	103RI.090102272G
10	25	72	10	5	103RI.100102572	103RI.100102572G
12	30	83	12	6	103RI.120123083	103RI.120123083G
14	30	83	14	7	103RI.140143083	103RI.140143083G
16	35	92	16	8	103RI.160163592	103RI.160163592G
18	35	92	18	9	103RI.180183592	103RI.180183592G
20	45	104	20	10	103RI.2002045104	103RI.2002045104G

Z=1 mit Rechtsdrall und Spanbrechernuten - WN

"ULTRA Ra" Speed Line mit feingeläppten Spannuten

Z=1 with right helix and chip breaker - Internal standard

"ULTRA Ra" Speed Line with fine lapped chip flutes

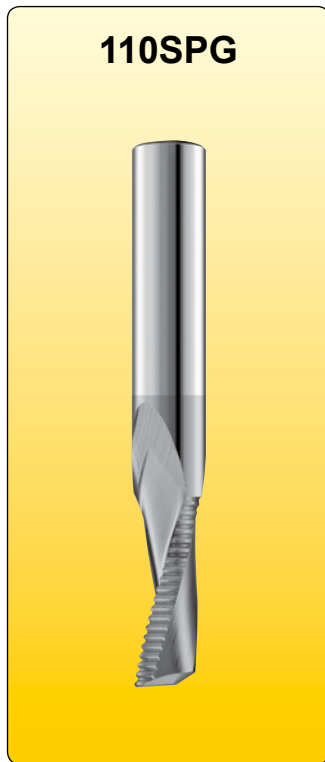
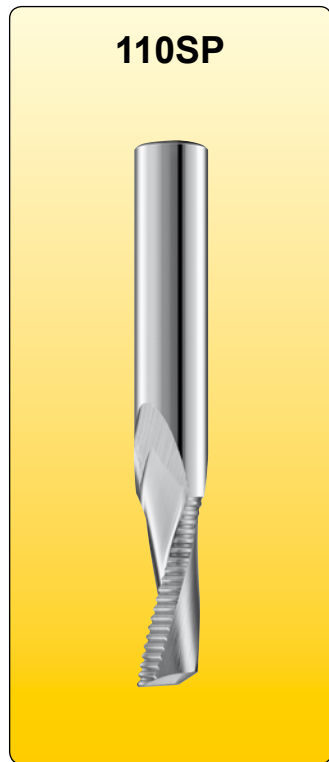

Einsatzgebiete / Range of application

A: Legierungen / Light alloys

A1.1-1.6

B: Kunststoffe - Faserverstärkte Kunststoffe

 B: *Plastics - Reinforced plastic fibres*

B1.1-1.3 B1.4-1.6 B2.1-2.4

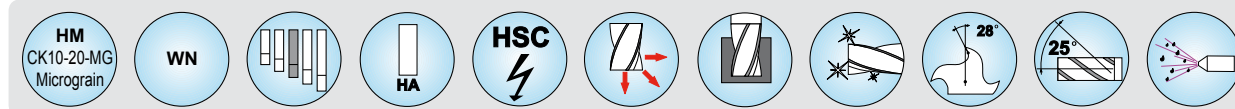
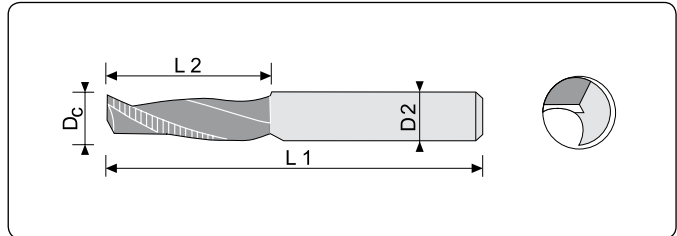

D _c h10	L2	L1	D2 h6	110SP	110SPG
					Beschichtet / Coated
3	7	50	6	110SP.030060750	110SP.030060750G
3	12	60	6	110SP.030061260	110SP.030061260G
4	9	50	6	110SP.040060950	110SP.040060950G
4	15	60	6	110SP.040061560	110SP.040061560G
5	11	50	6	110SP.050061150	110SP.050061150G
5	16	60	6	110SP.050061660	110SP.050061660G
6	13	50	6	110SP.060061350	110SP.060061350G
6	20	60	6	110SP.060062060	110SP.060062060G
8	22	63	8	110SP.080082263	110SP.080082263G
10	25	72	10	110SP.100102572	110SP.100102572G
12	30	83	12	110SP.120123083	110SP.120123083G
16	35	92	16	110SP.160163592	110SP.160163592G
20	40	104	20	110SP.2002040104	110SP.2002040104G

**2.
05**



2.
06

Schruppfräser
Roughing end mills

Schnittgeschwindigkeit V_c (m/min) für Schruppfräser
Cutting speed V_c (m/min) for roughing end mills

Schnittgeschwindigkeit V_c (m/min) / Cutting speed V_c (m/min)				
Gruppe C: Allgemeine Stahlwerkstoffe - Stahllegierungen - gehärtete Stähle Group C: General steels - Steel alloys - Hardened steels				
	Werkstoff Bezeichnung Material description	Festigkeit Strength N/mm ²	VHM Carbide	Cer-T
			V_c (m/min)	
C 1.1	Q-St-37-3	< 400	200	250
C 1.2	R-Fe80	< 400	200	250
C 1.3	9SMnPb28	500 - 700	150	200
C 1.4	St37-2	320 - 470	150	200
C 1.5	16MnCr5	500 - 700	100	150
C 1.6	Ck45	600 - 800	100	150
C 1.7	Gs25CrMo4	650 - 950	100	180
C 1.8	St70-2	700 - 900	120	180
C 2.1	100Cr6	700 - 900	100	150
C 2.2	X155CrVMo12-1	900 - 1100	80	120
C 2.3	X30WCrV5-3	1100	80	120
C 2.4	42CrMo4V	1200 - 1400	80	120
C 3.1	X38CrMoV5-3	900 - 1100	80	120
C 3.2	55NiCrMoV6	47 - 52 HRC		100
C 3.3	45WCrV7	56 - 60 HRC		100
C 3.4	X155CrVMo12-1	60 - 63 HRC		80
C 3.5	X210CrW12	63 - 66 HRC		80
C 4.1	FeroTiC	800 - 900		40
C 4.2	Hardox500	1300 - 1400		30

Gruppe F: Gußwerkstoffe Group F: Cast irons				
	Werkstoff Bezeichnung Material description	Festigkeit Strength N/mm ²	VHM Carbide	Cer-T
			V_c (m/min)	
F 1.1	GG 20	120-220 HB	120	160
F 1.2	GG 30	220 - 270 HB	100	150
F 1.3	Hartguß / Hard cast iron	< 400 HB		80
F 1.4	GTW40	360 - 420	100	160
F 1.5	GTS65	560 - 650	90	150
F 2.1	GGG 40	400	100	150
F 2.2	GGG 70	700 - 1050	100	150
F 2.3	GGV (80% Perlit)	220 HB	70	100
F 2.4	GGV (100% Perlit)	230 HB	60	100

2.
06

Schnittgeschwindigkeiten V_c (m/min) - Drehzahlen n (min^{-1})
Cutting speed V_c (m/min) - Revolution per minute n (min^{-1})

Berechnungsformeln: Schnittgeschwindigkeit V_c (m/min) - Drehzahl n (min^{-1})
Calculation formula: Cutting speed V_c (m/min) - Revolution per minute n (min^{-1})

$$V_c \text{ (m/min)} = \frac{D_c \text{ (mm)} \times 3,14 \times n \text{ (min}^{-1}\text{)}}{1000}$$

$$n \text{ (min}^{-1}\text{)} = \frac{V_c \text{ (m/min)} \times 1000}{D_c \text{ (mm)} \times 3,14}$$

D_c (mm)	V_c (m/min)										
	40	50	60	80	100	120	150	160	200	250	300
Drehzahl n (min^{-1}) / Revolution per minute n (min^{-1})											
2,00	6369	7962	9554	12739	15924	19108	23885	25478	31847	39809	47771
2,50	5096	6369	7643	10191	12739	15287	19108	20382	25478	31847	38217
3,00	4246	5308	6369	8493	10616	12739	15924	16985	21231	26539	31847
3,50	3640	4550	5460	7279	9099	10919	13649	14559	18198	22748	27298
4,00	3185	3981	4777	6369	7962	9554	11943	12739	15924	19904	23885
4,50	2831	3539	4246	5662	7077	8493	10616	11323	14154	17693	21231
5,00	2548	3185	3822	5096	6369	7643	9554	10191	12739	15924	19108
6,00	2123	2654	3185	4246	5308	6369	7962	8493	10616	13270	15924
8,00	1592	1990	2389	3185	3981	4777	5971	6369	7962	9952	11943
10,00	1274	1592	1911	2548	3185	3822	4777	5096	6369	7962	9554
12,00	1062	1327	1592	2123	2654	3185	3981	4246	5308	6635	7962
14,00	910	1137	1365	1820	2275	2730	3412	3640	4550	5687	6824
16,00	796	995	1194	1592	1990	2389	2986	3185	3981	4976	5971
18,00	708	885	1062	1415	1769	2123	2654	2831	3539	4423	5308
20,00	637	796	955	1274	1592	1911	2389	2548	3185	3981	4777
25,00	510	637	764	1019	1274	1529	1911	2038	2548	3185	3822
30,00	425	531	637	849	1062	1274	1592	1699	2123	2654	3185
32,00	398	498	597	796	995	1194	1493	1592	1990	2488	2986
35,00	364	455	546	728	910	1092	1365	1456	1820	2275	2730

Zahnvorschub f_z (mm) - für Schruppfräser (Richtwerte)
 Feed per tooth f_z (mm) - for roughing end mills (approximative values)

Schruppschlichtfräser f_z (mm) = Tabelle x 0,85
 Roughing finishing end mills f_z (mm) = table x 0,85

Schruppfräser f_z (mm) = nach Tabelle
 Roughing end mills f_z (mm) = according to table

Gruppe C - Allgemeine Stahlwerkstoffe - Stahllegierungen - gehärtete Stähle Group C - General steels - Steel alloys - Hardened steels													
	Eck-/ Konturenfräsen Side-Contour milling							Nutenfräsen Slot milling					
	$a_p = 1,5 \times D_c$			$a_e = 0,40 \times D_c$				$a_p = 1,0 \times D_c$					
	D _c (mm)												
	4,0	5,0	6,0	8,0	10,0	12,0	14,0	16,0	18,0	20,0	25,0	30,0	32,0
f_z (mm) für Werkzeuge mit Cer-T Beschichtung / f_z (mm) for tools with a coating of Cer-T													
C 1.1	0,013	0,017	0,020	0,026	0,032	0,040	0,046	0,052	0,058	0,064	0,079	0,084	0,088
C 1.2	0,013	0,017	0,020	0,026	0,032	0,040	0,046	0,052	0,058	0,064	0,079	0,084	0,088
C 1.3	0,013	0,017	0,020	0,026	0,032	0,040	0,046	0,052	0,058	0,064	0,079	0,084	0,088
C 1.4	0,013	0,017	0,020	0,026	0,032	0,040	0,046	0,052	0,058	0,064	0,079	0,084	0,088
C 1.5	0,011	0,014	0,017	0,022	0,027	0,033	0,038	0,043	0,048	0,053	0,066	0,070	0,073
C 1.6	0,011	0,014	0,017	0,022	0,027	0,033	0,038	0,043	0,048	0,053	0,066	0,070	0,073
C 1.7	0,012	0,015	0,019	0,024	0,030	0,036	0,042	0,047	0,053	0,058	0,073	0,077	0,080
C 1.8	0,012	0,015	0,019	0,024	0,030	0,036	0,042	0,047	0,053	0,058	0,073	0,077	0,080
C 2.1	0,011	0,014	0,017	0,022	0,027	0,033	0,038	0,043	0,048	0,053	0,066	0,070	0,073
C 2.2	0,009	0,011	0,014	0,018	0,022	0,026	0,030	0,034	0,038	0,042	0,053	0,056	0,058
C 2.3	0,009	0,011	0,014	0,018	0,022	0,026	0,030	0,034	0,038	0,042	0,053	0,056	0,058
C 2.4	0,009	0,011	0,014	0,018	0,022	0,026	0,030	0,034	0,038	0,042	0,053	0,056	0,058
C 3.1	0,009	0,011	0,014	0,018	0,022	0,026	0,030	0,034	0,038	0,042	0,053	0,056	0,058

2.
06

Gruppe F - Gusswerkstoffe Group F - Cast irons													
F 1.1	0,012	0,015	0,019	0,024	0,030	0,036	0,042	0,047	0,053	0,058	0,073	0,077	0,080
F 1.2	0,012	0,015	0,019	0,024	0,030	0,036	0,042	0,047	0,053	0,058	0,073	0,077	0,080
F 1.4	0,012	0,015	0,019	0,024	0,030	0,036	0,042	0,047	0,053	0,058	0,073	0,077	0,080
F 1.5	0,012	0,015	0,019	0,024	0,030	0,036	0,042	0,047	0,053	0,058	0,073	0,077	0,080
F 2.1	0,012	0,015	0,019	0,024	0,030	0,036	0,042	0,047	0,053	0,058	0,073	0,077	0,080
F 2.2	0,012	0,015	0,019	0,024	0,030	0,036	0,042	0,047	0,053	0,058	0,073	0,077	0,080
F 2.3	0,012	0,015	0,019	0,024	0,030	0,036	0,042	0,047	0,053	0,058	0,073	0,077	0,080
F 2.4	0,011	0,014	0,017	0,022	0,027	0,033	0,038	0,043	0,048	0,053	0,066	0,070	0,073
	0,011	0,014	0,017	0,022	0,027	0,033	0,038	0,043	0,048	0,053	0,066	0,070	0,073

für die Stoffgruppen "E und D" empfehlen wir unsere Fräser Typ "PIRAÑA"
 For material groups "E" and "D" end mills type "PIRAÑA" are suggested

Schrupfräser - Z=3 Drall 30° - Ähnlich DIN 6527-L Roughing end mills - Z=3 Helix 30° - Similar to DIN 6527-L

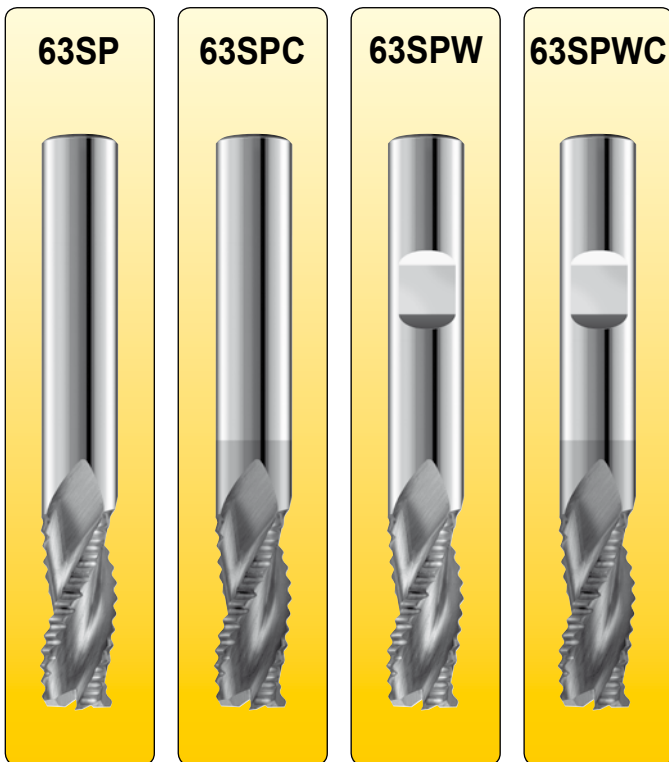

Einsatzgebiete / Range of application

C: Stahlwerkstoffe / Steels
C1.3 C2.1-2.3 C3.1 C4.1

D: Edelstahl / Stainless Steel
D1.1-1.4

E: Titan / Titanium
E2.1 E1.1-1.3 E2.1-2.3

F: Gußeisen / Cast irons
F1.1-1.2 F1.4-1.5 F2.1-2.2

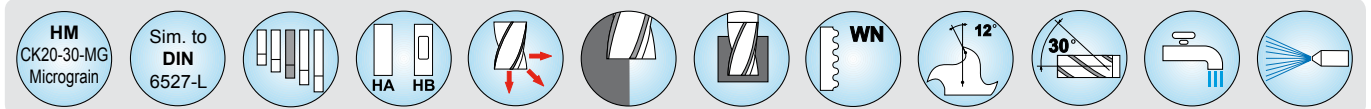
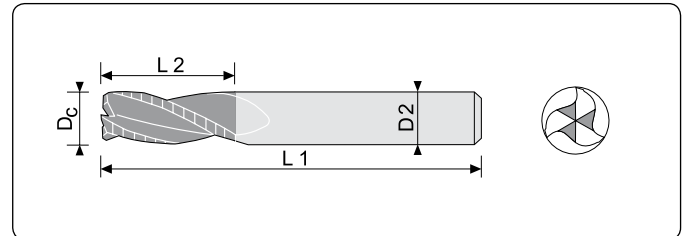

D _c h10	L2	L1	D2 h6	63SP	63SPC	63SPW	63SPWC
					Beschichtet / Coated		Beschichtet / Coated
6	10	57	6	63SP.060	63SP.060C	63SPW.060	63SPW.060C
8	19	63	8	63SP.080	63SP.080C	63SPW.080	63SPW.080C
10	22	72	10	63SP.100	63SP.100C	63SPW.100	63SPW.100C
12	26	83	12	63SP.120	63SP.120C	63SPW.120	63SPW.120C
14	26	83	14	63SP.140	63SP.140C	63SPW.140	63SPW.140C
16	30	92	16	63SP.160	63SP.160C	63SPW.160	63SPW.160C
18	30	92	18	63SP.180	63SP.180C	63SPW.180	63SPW.180C
20	38	104	20	63SP.200	63SP.200C	63SPW.200	63SPW.200C
25	45	120	25	63SP.250	63SP.250C	63SPW.250	63SPW.250C

2.
06

Schruppfräser - Z=4 Drall 30° - DIN 6527-L
Roughing end mills - Z=4 Helix 30° - DIN 6527-L

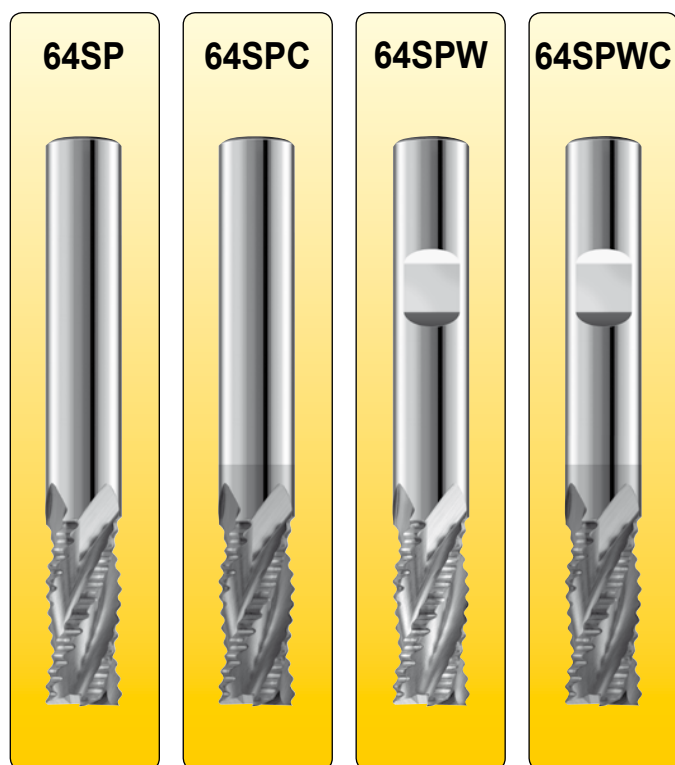

Einsatzgebiete / Range of application

- C: Stahlwerkstoffe / Steels
C1.1-1.8 C2.1-2.3 C3.1 C4.1
- D: Edelstahl / Stainless Steel
D1.1-1.4
- E: Titan / Titanium
E2.1
- F: Gußeisen / Cast irons
F1.1-1.2 F1.4-1.5 F2.1-2.2

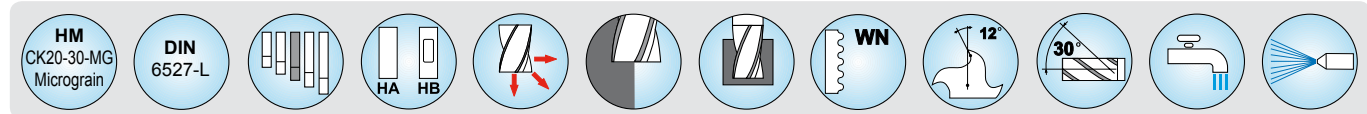
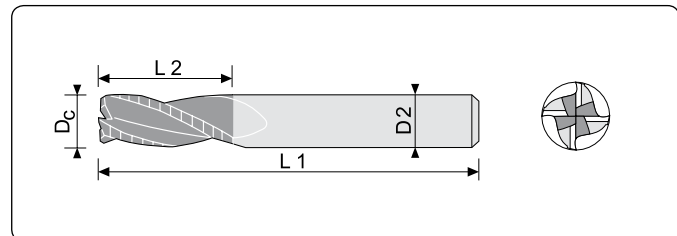

D _c h10	L2	L1	D2 h6	64SP	64SPC	64SPW	64SPWC
					Beschichtet / Coated		Beschichtet / Coated
6	13	57	6	64SP.060	64SP.060C	64SPW.060	64SPW.060C
8	19	63	8	64SP.080	64SP.080C	64SPW.080	64SPW.080C
10	22	72	10	64SP.100	64SP.100C	64SPW.100	64SPW.100C
12	26	83	12	64SP.120	64SP.120C	64SPW.120	64SPW.120C
14	26	83	14	64SP.140	64SP.140C	64SPW.140	64SPW.140C
16	32	92	16	64SP.160	64SP.160C	64SPW.160	64SPW.160C
18	32	92	18	64SP.180	64SP.180C	64SPW.180	64SPW.180C
20	38	104	20	64SP.200	64SP.200C	64SPW.200	64SPW.200C
25	45	120	25	64SP.250	64SP.250C	64SPW.250	64SPW.250C

2.
06



2.
07

Schaftfräser - mit 2 Schneiden
2 flutes end mills

Schnittgeschwindigkeit V_c (m/min) - für Standard Fräser
Cutting speed V_c (m/min) - for standard end mills

Schnittgeschwindigkeit V_c (m/min) / Cutting speed V_c (m/min)				
Gruppe C: Allgemeine Stahlwerkstoffe - Stahllegierungen - gehärtete Stähle <i>Group C - General steels - Steel alloys - Hardened steels</i>				
	Werkstoff Bezeichnung <i>Material description</i>	Festigkeit <i>Strength</i> N/mm ²	VHM Carbide V_c (m/min)	Cer-T
C 1.1	Q-St-37-3	< 400	200	250
C 1.2	R-Fe80	< 400	200	250
C 1.3	9SMnPb28	500 - 700	150	200
C 1.4	St37-2	320 - 470	150	200
C 1.5	16MnCr5	500 - 700	100	150
C 1.6	Ck45	600 - 800	100	150
C 1.7	Gs25CrMo4	650 - 950	100	180
C 1.8	St70-2	700 - 900	120	180
C 2.1	100Cr6	700 - 900	100	150
C 2.2	X155CrVMo12-1	900 - 1100	80	120
C 2.3	X30WCrV5-3	1100	80	120
C 2.4	42CrMo4V	1200 - 1400	80	120
C 3.1	X38CrMoV5-3	900 - 1100	80	120
C 3.2	55NiCrMoV6	47 - 52 HRC		100
C 4.1	FeroTiC	800 - 900		40
C 4.2	Hardox500	1300 - 1400		30
Gruppe D: Rost- Säure- und Hitzebeständige Stähle <i>Group D: corrosion-acid-resistant steels</i>				
D 1.1	X10NiCrAlTi32-20 (INCOLOY800)	610 - 850	60	90
D 1.2	X12CrNiTi18-9	500 - 700	60	90
D 1.3	X6CrNiMoTi17-12-2	500 - 730	60	90
D 1.4	X45SiCr4	900 - 1100		70
D 1.5	X5NiCrTi26-15	1200		50
Gruppe E: Nickel/Kobalt Legierungen - Titan - Titan Legierungen <i>Group E: Nickel/Cobalt alloys - Titanium - Titanium alloys</i>				
E 1.1	Ti3 (Ti99.4)	700	100	120
E 1.2	TiAl6V4	700 - 900	80	100
E 1.3	TiAlMo4Sn2	900 - 1250		80
E 2.1	NiCu30Fe (MONEL400I)	420 - 610		70
E 2.2	NiCr19NbMo (INCONEL718)	850-1200		60
E 2.3	Haynes 25 (L605)	1550 - 2000		40
Gruppe F - Gusswerkstoffe <i>Group F - Cast irons</i>				
F 1.1	GG 20	120-220 HB	140	160
F 1.2	GG 30	220 - 270 HB	100	150
F 1.3	Hartguß / <i>Hard cast iron</i>	< 400 HB		80
F 1.4	GTW40	360 - 420	120	160
F 1.5	GTS65	560 - 650	100	150
F 2.1	GGG 40	400	120	150
F 2.2	GGG 70	700 - 1050	100	150
F 2.3	GGV (80% Perlit)	220 HB	70	100
F 2.4	GGV (100% Perlit)	230 HB	60	100

Zahnvorschub f_z (mm) - für Standard Fräser (Richtwerte)
 Feed per tooth f_z (mm) - for standard end mills (approximative values)

Radius- und Schafffräser
 Ball nose cutters and end mills

DIN 6527/28 mit Spiralwinkel / $30^\circ = f_z$ (mm) nach Tabelle / $45^\circ = f_z$ (mm) Tabelle x 0,70
 DIN 6527/28 with helix angle / $30^\circ = f_z$ (mm) according to table / $45^\circ = f_z$ (mm) Table x 0,70

WN überlang - extralang - f_z (mm) x 0,65
 Internal standard long - extra long f_z (mm) x 0,65

Gruppe C - Allgemeine Stahlwerkstoffe - Stahllegierungen - gehärtete Stähle Group C - General steels - Steel alloys - Hardened steels													
	Eck-/ Konturenfräsen Side-Contour milling							Nutenfräsen Slot milling					
	$a_p = 1,5 \times D_c$			$a_e = 0,25 \times D_c$				$a_p = 0,50 \times D_c$					
	D_c (mm)												
	2,0	3,0	4,0	5,0	6,0	8,0	10,0	12,0	14,0	16,0	18,0	20,0	25,0
f_z (mm) für unbeschichtete Werkzeuge / f_z (mm) for uncoated tools													
C 1.1	0,005	0,008	0,012	0,014	0,017	0,023	0,034	0,034	0,038	0,044	0,050	0,055	0,070
C 1.2	0,005	0,008	0,012	0,014	0,017	0,023	0,034	0,034	0,038	0,044	0,050	0,055	0,070
C 1.3	0,005	0,008	0,012	0,014	0,017	0,023	0,034	0,034	0,038	0,044	0,050	0,055	0,070
C 1.4	0,005	0,008	0,012	0,014	0,017	0,023	0,034	0,034	0,038	0,044	0,050	0,055	0,070
C 1.5	0,004	0,007	0,010	0,012	0,014	0,019	0,028	0,028	0,032	0,037	0,042	0,046	0,058
C 1.6	0,004	0,007	0,010	0,012	0,014	0,019	0,028	0,028	0,032	0,037	0,042	0,046	0,058
C 1.7	0,004	0,008	0,011	0,013	0,015	0,021	0,031	0,031	0,035	0,041	0,046	0,051	0,064
C 1.8	0,004	0,008	0,011	0,013	0,015	0,021	0,031	0,031	0,035	0,041	0,046	0,051	0,064
C 2.1	0,004	0,007	0,010	0,012	0,014	0,019	0,028	0,028	0,032	0,037	0,042	0,046	0,058
C 2.2	0,003	0,006	0,008	0,010	0,011	0,015	0,022	0,022	0,026	0,030	0,034	0,037	0,046
C 2.3	0,003	0,006	0,008	0,010	0,011	0,015	0,022	0,022	0,026	0,030	0,034	0,037	0,046
■ C 2.4	0,003	0,006	0,008	0,010	0,011	0,015	0,022	0,022	0,026	0,030	0,034	0,037	0,046
■ C 3.1	0,003	0,006	0,008	0,010	0,011	0,015	0,022	0,022	0,026	0,030	0,034	0,037	0,046
■ C 3.2	0,003	0,005	0,007	0,008	0,010	0,013	0,020	0,020	0,022	0,026	0,029	0,032	0,041
C 4.1	0,003	0,005	0,007	0,008	0,010	0,013	0,020	0,020	0,022	0,026	0,029	0,032	0,041
■ C 4.2	0,003	0,005	0,007	0,008	0,010	0,013	0,020	0,020	0,022	0,026	0,029	0,032	0,041

■ ACHTUNG: Für diese Werkstückwerkstoffe sind Fräser mit 45° Drall nicht geeignet
 ■ NOTE: For this kind of materials 45° helix cutters are not suitable

Mit unseren HPC Werkzeugen (z.B. PIRAÑA-SV) können die Schnittdaten, bei geeigneten Werkzeugmaschinen, Werkstücken und Werkstückspannungen, deutlich erhöht werden.
 With our HPC High Performance Cutters (i.e. PIRAÑA-SV) the cutting data, using appropriate machine tools, material and work piece clamping, can be substantially increased.

Zahnvorschub f_z (mm) - für Standard Fräser (Richtwerte)
Feed per tooth f_z (mm) - for standard end mills (approximative values)

Radius- und Schafffräser / Ball nose cutters and end mills													
Gruppe D: Rost- Säure- und Hitzebeständige Stähle													
Group D: corrosion-acid-resistant steels													
	Eck-/ Konturenfräsen										Nutenfräsen		
	Side-Contour milling										Slot milling		
	$a_p = 1,5 \times D_c$					$a_e = 0,20 \times D_c$					$a_p = 0,40 \times D_c$		
	D_c (mm)												
	2,0	3,0	4,0	5,0	6,0	8,0	10,0	12,0	14,0	16,0	18,0	20,0	25,0
f_z (mm) für unbeschichtete Werkzeuge / f_z (mm) for uncoated tools													
D 1.1	0,004	0,007	0,009	0,010	0,013	0,018	0,022	0,027	0,031	0,036	0,040	0,044	0,056
D 1.2	0,004	0,007	0,009	0,010	0,013	0,018	0,022	0,027	0,031	0,036	0,040	0,044	0,056
D 1.3	0,004	0,007	0,009	0,010	0,013	0,018	0,022	0,027	0,031	0,036	0,040	0,044	0,056
D 1.4	0,004	0,006	0,008	0,009	0,012	0,016	0,020	0,024	0,028	0,032	0,036	0,040	0,050
D 1.5	0,003	0,005	0,006	0,007	0,009	0,013	0,015	0,019	0,022	0,025	0,028	0,031	0,039

Gruppe E: Nickel/Kobalt Legierungen - Titan - Titan Legierungen													
Group E: Nickel/Cobalt alloys - Titanium - Titanium alloys													
	Eck-/ Konturenfräsen										Nutenfräsen		
	Side-Contour milling										Slot milling		
	$a_p = 1,5 \times D_c$					$a_e = 0,20 \times D_c$					$a_p = 0,40 \times D_c$		
	D_c (mm)												
	2,0	3,0	4,0	5,0	6,0	8,0	10,0	12,0	14,0	16,0	18,0	20,0	25,0
f_z (mm) für unbeschichtete Werkzeuge / f_z (mm) for uncoated tools													
E 1.1	0,004	0,007	0,009	0,010	0,013	0,018	0,022	0,027	0,031	0,036	0,040	0,044	0,056
E 1.2	0,004	0,007	0,009	0,010	0,013	0,018	0,022	0,027	0,031	0,036	0,040	0,044	0,056
E 1.3	0,004	0,006	0,008	0,009	0,012	0,016	0,020	0,024	0,028	0,032	0,036	0,040	0,050
E 2.1	0,004	0,008	0,010	0,011	0,014	0,020	0,024	0,030	0,034	0,040	0,044	0,048	0,062
E 2.2	0,004	0,007	0,009	0,010	0,013	0,018	0,022	0,027	0,031	0,036	0,040	0,044	0,056
E 2.3	0,003	0,005	0,006	0,007	0,009	0,013	0,015	0,019	0,022	0,025	0,028	0,031	0,039

Gruppe F - Gusswerkstoffe													
Group F - Cast irons													
	Eck-/ Konturenfräsen										Nutenfräsen		
	Side-Contour milling										Slot milling		
	$a_p = 1,5 \times D_c$					$a_e = 0,25 \times D_c$					$a_p = 0,50 \times D_c$		
	D_c (mm)												
	2,0	3,0	4,0	5,0	6,0	8,0	10,0	12,0	14,0	16,0	18,0	20,0	25,0
f_z (mm) für unbeschichtete Werkzeuge / f_z (mm) for uncoated tools													
F 1.1	0,004	0,008	0,010	0,011	0,014	0,020	0,024	0,030	0,034	0,040	0,044	0,048	0,062
F 1.2	0,004	0,008	0,010	0,011	0,014	0,020	0,024	0,030	0,034	0,040	0,044	0,048	0,062
F 1.3	0,003	0,006	0,007	0,008	0,010	0,014	0,018	0,022	0,025	0,029	0,032	0,035	0,045
F 1.4	0,004	0,008	0,010	0,011	0,014	0,020	0,024	0,030	0,034	0,040	0,044	0,048	0,062
F 1.5	0,004	0,008	0,010	0,011	0,014	0,020	0,024	0,030	0,034	0,040	0,044	0,048	0,062
F 2.1	0,004	0,008	0,010	0,011	0,014	0,020	0,024	0,030	0,034	0,040	0,044	0,048	0,062
F 2.2	0,004	0,008	0,010	0,011	0,014	0,020	0,024	0,030	0,034	0,040	0,044	0,048	0,062
F 2.3	0,004	0,007	0,009	0,010	0,013	0,018	0,022	0,027	0,031	0,036	0,040	0,044	0,056
F 2.4	0,004	0,007	0,009	0,010	0,013	0,018	0,022	0,027	0,031	0,036	0,040	0,044	0,056

Radiusfräser - Z=2 gerade genutet - WN

"ULTRA Ra" Speed Line mit feingeläppten Spannuten

Radius end mills - Z=2 straight flute - Internal standard

"ULTRA Ra" Speed Line with fine lapped chip flutes



Einsatzgebiete / Range of application

C: Stahlwerkstoffe / Steels
C1.1-1.8 C2.1-2.3 C4.1

D: Edelstahl / Stainless Steel
D1.1-1.3

E: Titan / Titanium
E1.1-1.2 E2.1

F: Gußeisen / Cast irons
F1.1-1.2 F1.4-1.5 F2.1

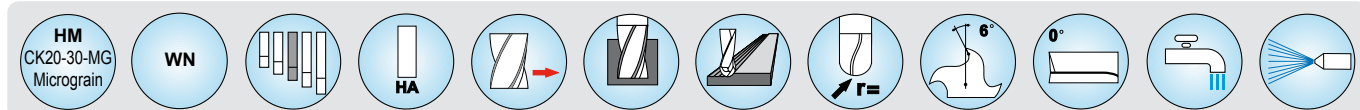
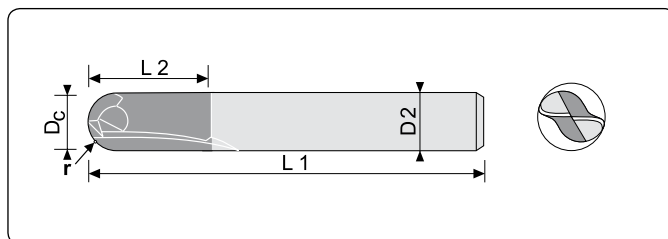

D _c h10	L2	L1	D2 h6	r	62TDR	62TDRA
						Beschichtet / Coated
3	8	40	3	1,5	62TDR.030	62TDR.030A
4	10	40	4	2	62TDR.040	62TDR.040A
6	12	50	6	3	62TDR.060	62TDR.060A
8	16	63	8	4	62TDR.080	62TDR.080A
10	20	72	10	5	62TDR.100	62TDR.100A
12	22	83	12	6	62TDR.120	62TDR.120A
14	22	83	14	7	62TDR.140	62TDR.140A
16	25	92	16	8	62TDR.160	62TDR.160A
18	25	92	18	9	62TDR.180	62TDR.180A
20	30	104	20	10	62TDR.200	62TDR.200A

2.
07

Schaftfräser - Z=2 Drall 30° - Ähnlich DIN 6527-L End mills - Z=2 Helix 30° - Similar to DIN 6527-L

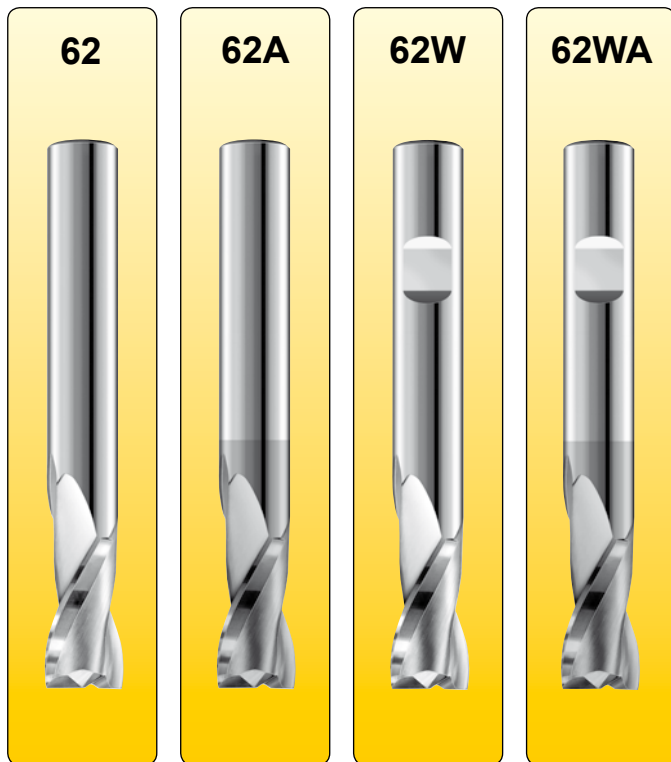

Einsatzgebiete / Range of application

C: Stahlwerkstoffe / Steels
C1.1-1.8 C2.1-2.3 C3.1-3.2 C4.1-4.2

D: Edelstahl / Stainless Steel
D1.1-1.5

F: Gußeisen / Cast irons
F1.1-1.5 F2.1-2.4

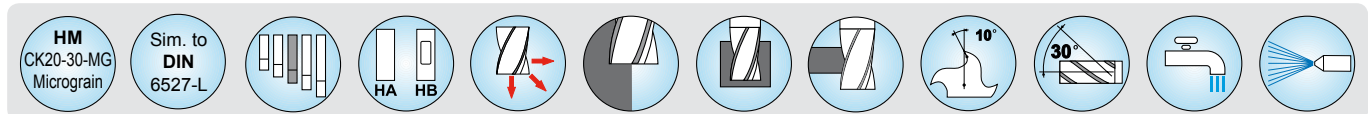
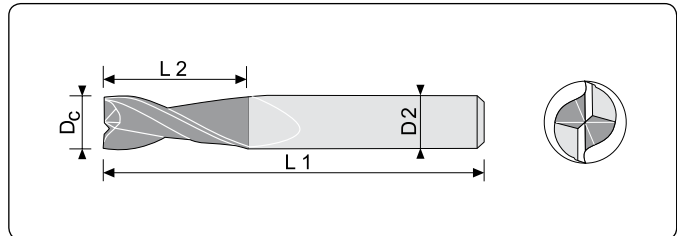

D _c h10	L2	L1	D2 h6	62	62A	62W	62WA
				□	Beschichtet/Coated	□	Beschichtet/Coated
2	6	40	2	62.020020640	62.020020640A		
2	3	50	6	62.020060350	62.020060350A		
2,5	7	40	2,5	62.025250740	62.025250740A		
2,5	3	50	6	62.025060350	62.025060350A		
3	7	57	6	62.030060757	62.030060757A	62W.030060757	62W.030060757A
3	8	40	3	62.030030840	62.030030840A		
3,5	8	40	3,5	62.035350840	62.035350840A		
4	8	57	6	62.040060857	62.040060857A	62W.040060857	62W.040060857A
4	10	40	4	62.040041040	62.040041040A		
4,5	10	50	4,5	62.045451050	62.045451050A		
5	12	50	5	62.050051250	62.050051250A		
5,5	12	50	5,5	62.055551250	62.055551250A		
6	10	57	6	62.060061057	62.060061057A	62W.060061057	62W.060061057A
6	14	50	6	62.060061450	62.060061450A		
6,5	14	50	6,5	62.065651450	62.065651450A		
7	15	60	7	62.070071560	62.070071560A		
8	16	63	8	62.080081663	62.080081663A	62W.080081663	62W.080081663A
9	19	63	9	62.090091963	62.090091963A		
10	19	72	10	62.100101972	62.100101972A	62W.100101972	62W.100101972A
11	22	72	11	62.110112272	62.110112272A		
12	22	83	12	62.120122283	62.120122283A	62W.120122283	62W.120122283A
13	22	83	13	62.130132283	62.130132283A		
14	22	83	14	62.140142283	62.140142283A	62W.140142283	62W.140142283A
15	26	92	15	62.150152692	62.150152692A		
16	26	92	16	62.160162692	62.160162692A	62W.160162692	62W.160162692A
18	26	92	18	62.180182692	62.180182692A	62W.180182692	62W.180182692A
20	32	104	20	62.2002032104	62.2002032104A	62W.2002032104	62W.2002032104A
25	45	120	25	62.2502545120	62.2502545120A	62W.2502545120	62W.2502545120A

2.
07

Schafffräser - Z=2 Drall 45° - DIN 6527-L End Mills - Z=2 Helix 45° - DIN 6527-L

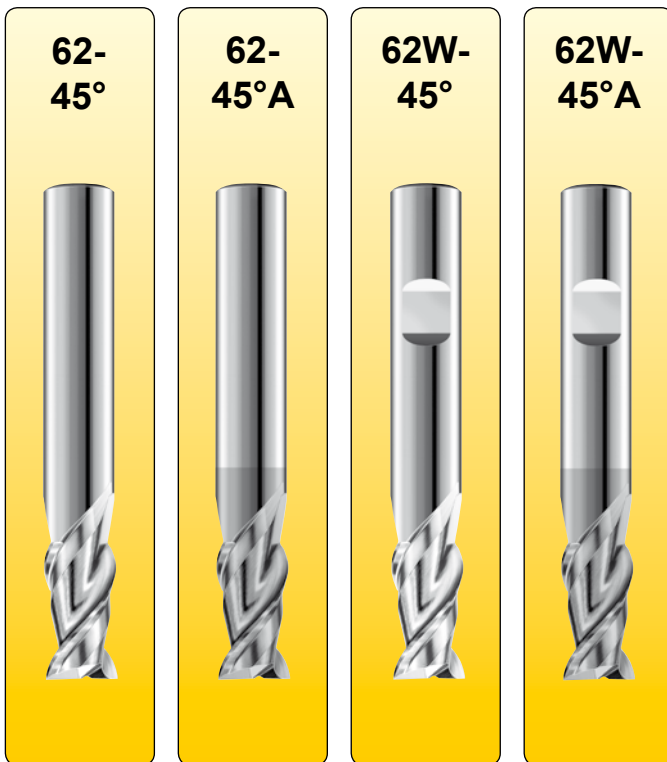

Einsatzgebiete / Range of application

A: Legierungen / Light alloys
A1.3-1.6 A2.4-2.7 A3.1-3.2 A4.1-4.2

C: Stahlwerkstoffe / Steels
C1.1-1.8 C2.1-2.3 C4.1

D: Edelstahl / Stainless Steel
D1.1-1.4

E: Titan / Titanium
E1.1-1.2 E2.1

F: Gußeisen / Cast irons
F1.1-1.2 F1.4-1.5 F2.1-2.4

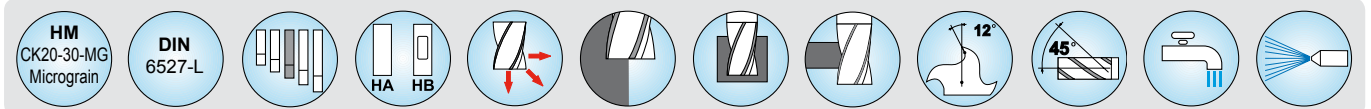
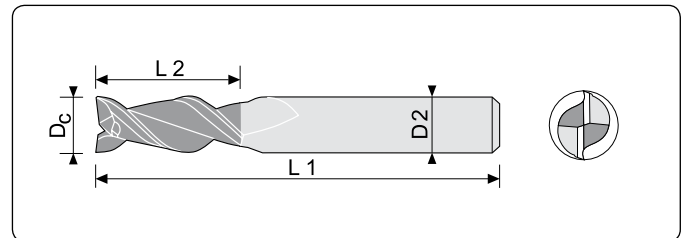

D _c h10	L2	L1	D2 h6	62-45°	62-45°A	62W-45°	62W-45°A
					Beschichtet / Coated		Beschichtet / Coated
3	7	57	6	62.030060757-45°	62.030060757-45°A	62W.030060757-45°	62W.030060757-45°A
4	8	57	6	62.040060857-45°	62.040060857-45°A	62W.040060857-45°	62W.040060857-45°A
5	10	57	6	62.050061057-45°	62.050061057-45°A	62W.050061057-45°	62W.050061057-45°A
6	10	57	6	62.060061057-45°	62.060061057-45°A	62W.060061057-45°	62W.060061057-45°A
7	13	63	8	62.070081363-45°	62.070081363-45°A	62W.070081363-45°	62W.070081363-45°A
8	16	63	8	62.080081663-45°	62.080081663-45°A	62W.080081663-45°	62W.080081663-45°A
9	16	72	10	62.090101672-45°	62.090101672-45°A	62W.090101672-45°	62W.090101672-45°A
10	19	72	10	62.100101972-45°	62.100101972-45°A	62W.100101972-45°	62W.100101972-45°A
11	22	83	12	62.110122283-45°	62.110122283-45°A	62W.110122283-45°	62W.110122283-45°A
12	22	83	12	62.120122283-45°	62.120122283-45°A	62W.120122283-45°	62W.120122283-45°A
14	22	83	14	62.140142283-45°	62.140142283-45°A	62W.140142283-45°	62W.140142283-45°A
16	26	92	16	62.160162692-45°	62.160162692-45°A	62W.160162692-45°	62W.160162692-45°A
18	26	92	18	62.180182692-45°	62.180182692-45°A	62W.180182692-45°	62W.180182692-45°A
20	32	104	20	62.2002032104-45°	62.2002032104-45°A	62W.2002032104-45°	62W.2002032104-45°A
25	45	120	25	62.2502545120-45°	62.2502545120-45°A	62W.2502545120-45°	62W.2502545120-45°A

2.
07

Radius Schaftfräser - Z=2 Drall 30° - Ähnlich DIN 6527-L
Ball nose end mills - Z=2 Helix 30° - Similar to DIN 6527-L

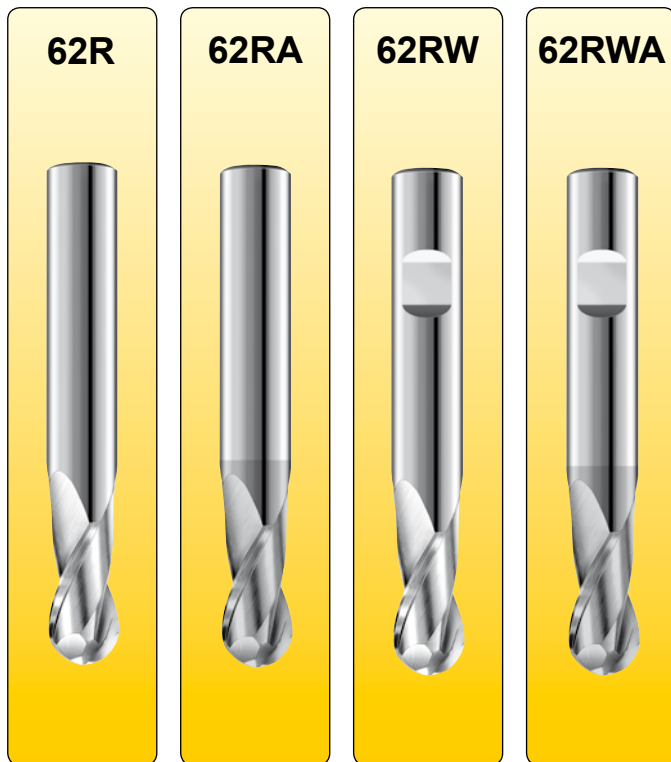

Einsatzgebiete / Range of application

C: Stahlwerkstoffe / Steels
 C1.1-1 C2.1-2.4 C3.1-3.2 C4.1-4.2

D: Edelstahl / Stainless Steel
 D1.1-1.5

F: Gußeisen / Cast irons
 F1.1-1.5 F2.1-2.4

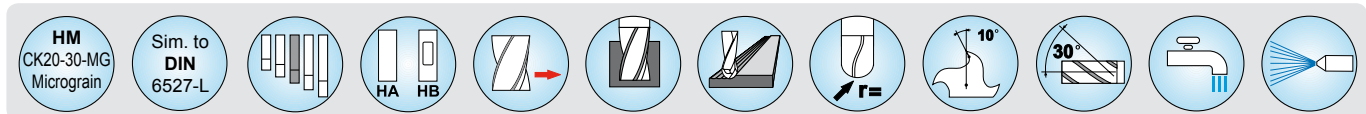
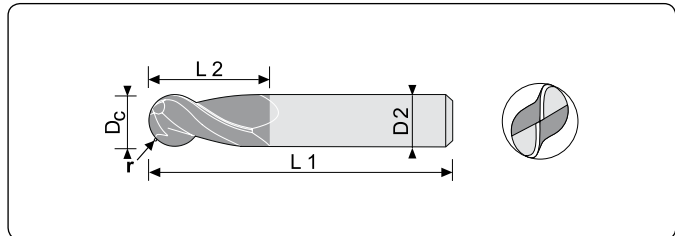

D _c h10	L2	L1	D2 h6	r	62R	62RA	62RW	62RWA
						Beschichtet/Coated		Beschichtet/Coated
2	6	40	2	1	62R.020020640	62R.020020640A		
2,5	7	40	2,5	1,25	62R.025250740	62R.025250740A		
3	7	57	6	1,5	62R.030060757	62R.030060757A	62RW.030060757	62RW.030060757A
3	8	40	3	1,5	62R.030030840	62R.030030840A		
3,5	8	40	3,5	1,75	62R.035350840	62R.035350840A		
4	8	57	6	2	62R.040060857	62R.040060857A	62RW.040060857	62RW.040060857A
4	10	40	4	2	62R.040041040	62R.040041040A		
4,5	10	50	4,5	2,25	62R.045451050	62R.045451050A		
5	12	50	5	2,5	62R.050051250	62R.050051250A		
5,5	12	50	5,5	2,75	62R.055551250	62R.055551250A		
6	10	57	6	3	62R.060061057	62R.060061057A	62RW.060061057	62RW.060061057A
6	14	50	6	3	62R.060061450	62R.060061450A		
6,5	14	50	6,5	3,25	62R.065651450	62R.065651450A		
7	15	60	7	3,5	62R.070071560	62R.070071560A		
8	16	63	8	4	62R.080081663	62R.080081663A	62RW.080081663	62RW.080081663A
9	18	63	9	4,5	62R.090091863	62R.090091863A		
10	19	72	10	5	62R.100101972	62R.100101972A	62RW.100101972	62RW.100101972A
11	22	72	11	5,5	62R.110112272	62R.110112272A		
12	22	83	12	6	62R.120122283	62R.120122283A	62RW.120122283	62RW.120122283A
13	22	83	13	6,5	62R.130132283	62R.130132283A		
14	22	83	14	7	62R.140142283	62R.140142283A	62RW.140142283	62RW.140142283A
15	26	92	15	7,5	62R.150152692	62R.150152692A		
16	26	92	16	8	62R.160162692	62R.160162692A	62RW.160162692	62RW.160162692A
18	26	92	18	9	62R.180182692	62R.180182692A	62RW.180182692	62RW.180182692A
20	32	104	20	10	62R.2002032104	62R.2002032104A	62RW.2002032104	62RW.2002032104A
25	45	120	25	12,5	62R.2502545120	62R.2502545120A	62RW.2502545120	62RW.2502545120A

Radius Schaftfräser - Z=2 Drall 30° - WN überlang
Ball nose end mills - Z=2 Helix 30° - Internal standard long

Einsatzgebiete / Range of application

C: Stahlwerkstoffe / Steels
 C1.1-8 C2.1-2.4 C3.1-3.2 C4.1-4.2

D: Edelstahl / Stainless Steel
 D1.1-1.5

F: Gußeisen / Cast irons
 F1.1-1.5 F2.1-2.4

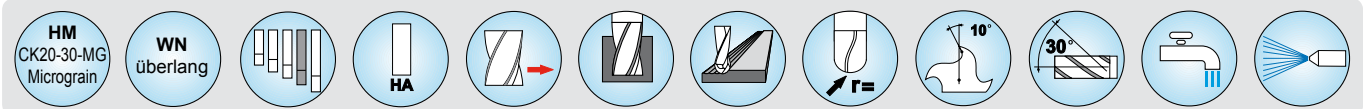
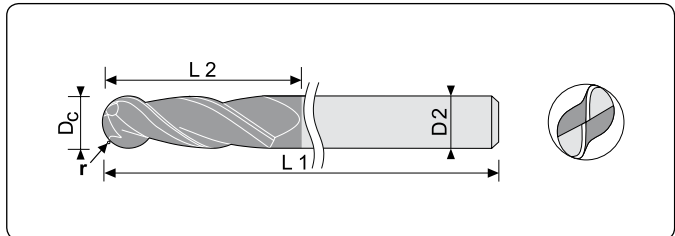
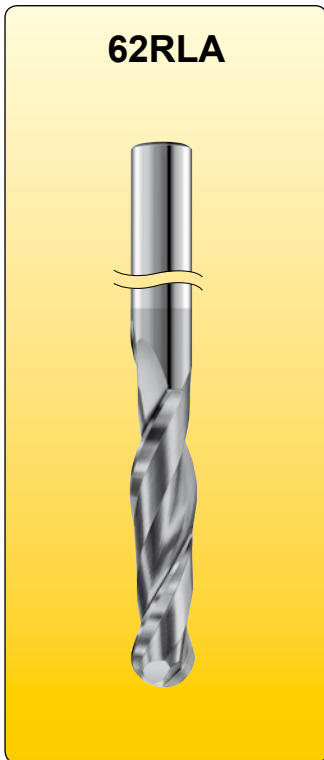
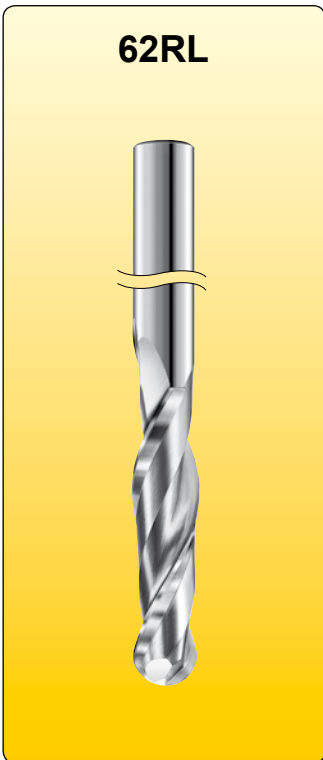

D _c h10	L2	L1	D2 h6	r	62RL	62RLA
						Beschichtet / Coated
3	18	60	3	1,5	62RL.030	62RL.030A
4	20	60	4	2	62RL.040	62RL.040A
5	25	62	5	2,5	62RL.050	62RL.050A
6	30	70	6	3	62RL.060	62RL.060A
8	35	79	8	4	62RL.080	62RL.080A
10	40	89	10	5	62RL.100	62RL.100A
12	50	100	12	6	62RL.120	62RL.120A
14	58	125	14	7	62RL.140	62RL.140A
16	58	125	16	8	62RL.160	62RL.160A
18	58	125	18	9	62RL.180	62RL.180A
20	60	125	20	10	62RL.200	62RL.200A

2.
07

Radius Schaftfräser - Z=2 Drall 30° - WN extralang Ball nose end mills - Z=2 Helix 30° - Internal standard extra long

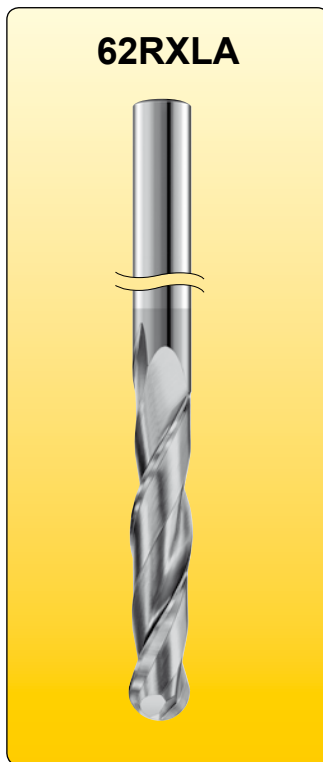
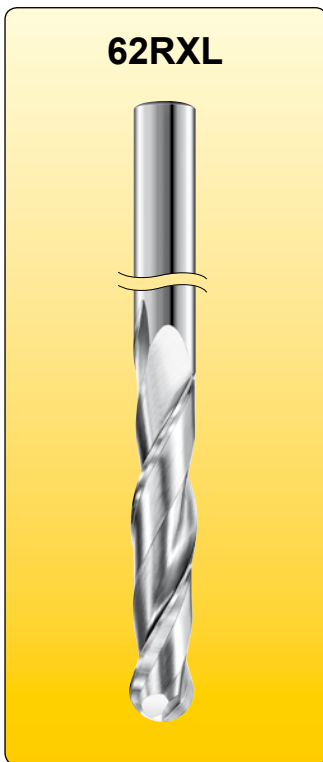

Einsatzgebiete / Range of application

C: Stahlwerkstoffe / Steels
C1.1-8 C2.1-2.4 C3.1-3.2 C4.1-4.2

D: Edelstahl / Stainless Steel
D1.1-1.5

F: Gußeisen / Cast irons
F1.1-1.5 F2.1-2.4

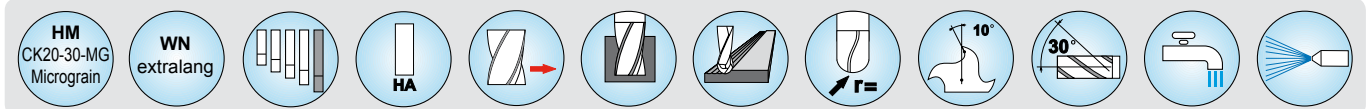
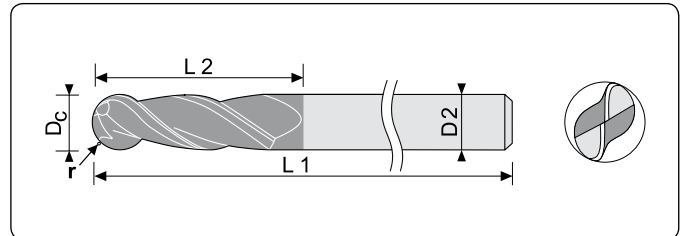

D _c h10	L2	L1	D2 h6	r	62RXL	62RXLA
						Beschichtet / Coated
3	25	75	3	1,5	62RXL.030	62RXL.030A
4	32	75	4	2	62RXL.040	62RXL.040A
5	38	100	5	2,5	62RXL.050	62RXL.050A
6	40	100	6	3	62RXL.060	62RXL.060A
8	45	100	8	4	62RXL.080	62RXL.080A
10	50	120	10	5	62RXL.100	62RXL.100A
12	60	150	12	6	62RXL.120	62RXL.120A
14	75	150	14	7	62RXL.140	62RXL.140A
16	75	150	16	8	62RXL.160	62RXL.160A
18	75	150	18	9	62RXL.180	62RXL.180A
20	75	150	20	10	62RXL.200	62RXL.200A

2.
07



Schaftfräser - mit 3 Schneiden
3 flutes end mills

Schafffräser - Z=3 "PIRAÑA"-SQ ungleiche Schneidenteilung und - Spiralwinkel - DIN 6527-L End Mills - Z=3 "PIRAÑA"-SQ uneven division of cutting edges and helix angle - DIN 6527-L

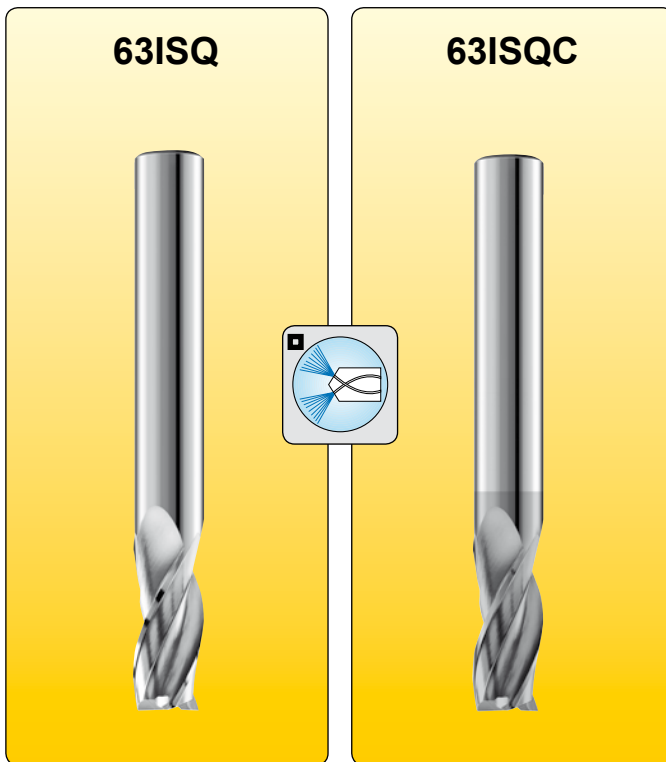

Einsatzgebiete / Range of application

A: Legierungen / Light alloys
A1.3-1.6 A2.4-2.7 A3.1-3.2 A4.1-4.2

C: Stahlwerkstoffe / Steels
C1.1-1.8 C2.1-2.4 C4.1

D: Edelstahl / Stainless Steel
D1.1-1.4

E: Titan / Titanium
E1.1-1.2 E2.1

F: Gußeisen / Cast irons
F1.1-1.2 F1.4-1.5 F2.1-2.4

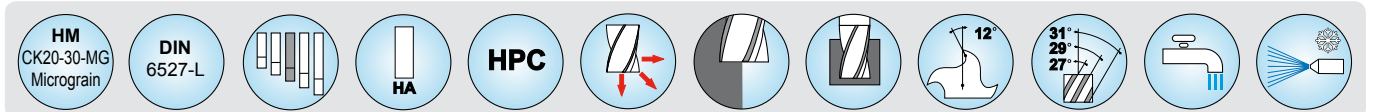
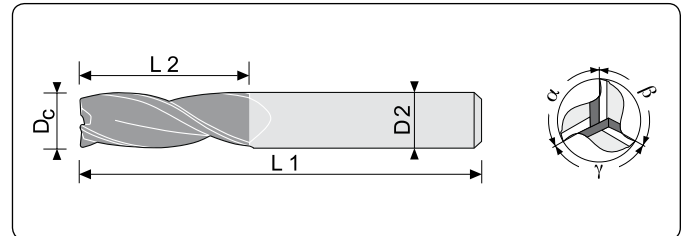

D _c h10	L2	L1	D2 h6	63ISQ	63ISQC
				Beschichtet / Coated	Beschichtet / Coated
3	7	57	6	63ISQ.030	63ISQ.030C
4	8	57	6	63ISQ.040	63ISQ.040C
5	10	57	6	63ISQ.050	63ISQ.050C
6	10	57	6	63ISQ.060	63ISQ.060C
8	16	63	8	63ISQ.080	63ISQ.080C
10	19	72	10	63ISQ.100	63ISQ.100C
12	22	83	12	63ISQ.120	63ISQ.120C
14	22	83	14	63ISQ.140	63ISQ.140C
16	26	92	16	63ISQ.160	63ISQ.160C
20	32	104	20	63ISQ.200	63ISQ.200C

■ Auf Anfrage ab 8 mm auch mit "Kühlkanälen" lieferbar. - Fügen Sie am Ende der Bestell Nr. iK ein
■ On request from 8 mm also available with "coolant ducts". - Add at the end of the Order No ... iK

Schafffräser - Z=3 "PIRAÑA"-SQ ungleiche Schneidenteilung und -Spiralwinkel - DIN 6527-L
End Mills - Z=3 "PIRAÑA"-SQ uneven division of cutting edges and helix angle - DIN 6527-L

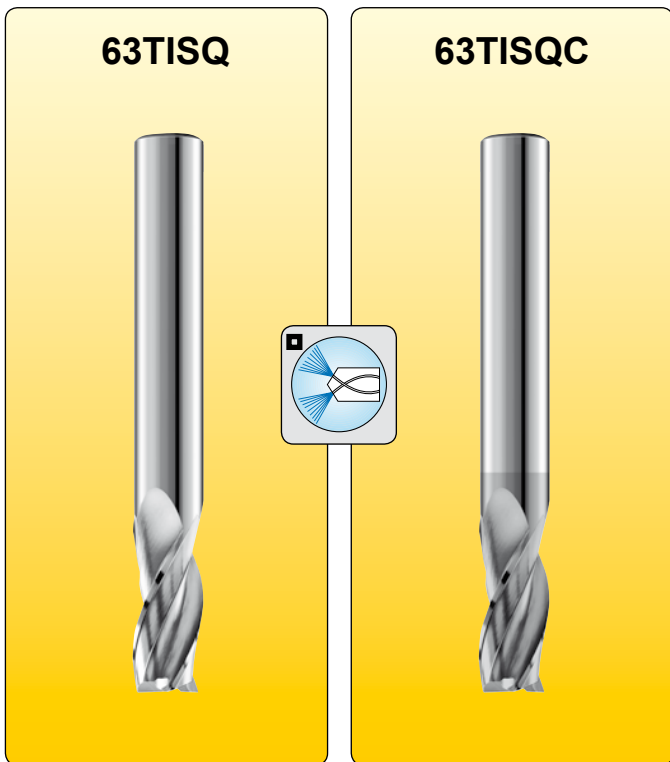

Einsatzgebiete / Range of application

A: Legierungen / Light alloys
 A1.3-1.6 A2.4-2.7 A3.1-3.2 A4.1-4.2

C: Stahlwerkstoffe / Steels
 C1.1-1.8 C2.1-2.4 C4.1

D: Edelstahl / Stainless Steel
 D1.1-1.4

E: Titan / Titanium
 E1.1-1.2 E2.1

F: Gußeisen / Cast irons
 F1.1-1.2 F1.4-1.5 F2.1-2.4

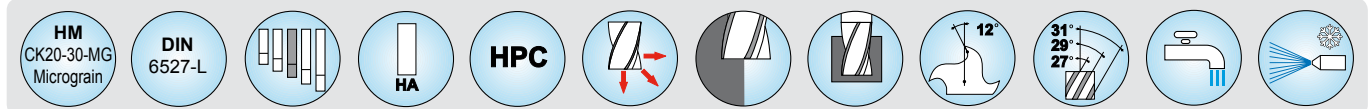
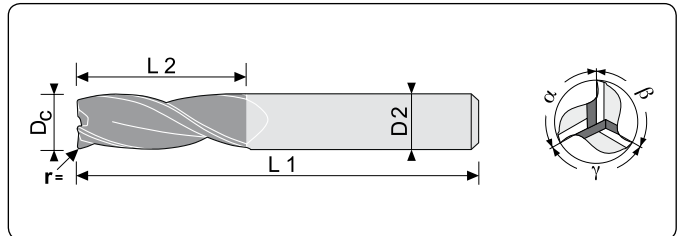

D _c h10	L2	L1	D2 h6	r	63TISQ	63TISQC
						Beschichtet / Coated
3	7	57	6	0,3	63TISQ.030	63TISQ.030C
4	8	57	6	0,4	63TISQ.040	63TISQ.040C
5	10	57	6	0,5	63TISQ.050	63TISQ.050C
6	10	57	6	1,0	63TISQ.060	63TISQ.060C
8	16	63	8	1,0	63TISQ.080	63TISQ.080C
10	19	72	10	1,5	63TISQ.100	63TISQ.100C
12	22	83	12	1,5	63TISQ.120	63TISQ.120C
14	22	83	14	1,5	63TISQ.140	63TISQ.140C
16	26	92	16	2,0	63TISQ.160	63TISQ.160C
20	32	104	20	2,0	63TISQ.200	63TISQ.200C

**2.
08**

■ Auf Anfrage ab 8 mm auch mit "Kühlkanälen" lieferbar. - Fügen Sie am Ende der Bestell Nr. iK ein
 ■ On request from 8 mm also available with "coolant ducts". - Add at the end of the Order No ... iK

Schafffräser - Z=3 Drall 30° - WN End mills - Z=3 Helix 30° - Internal standard

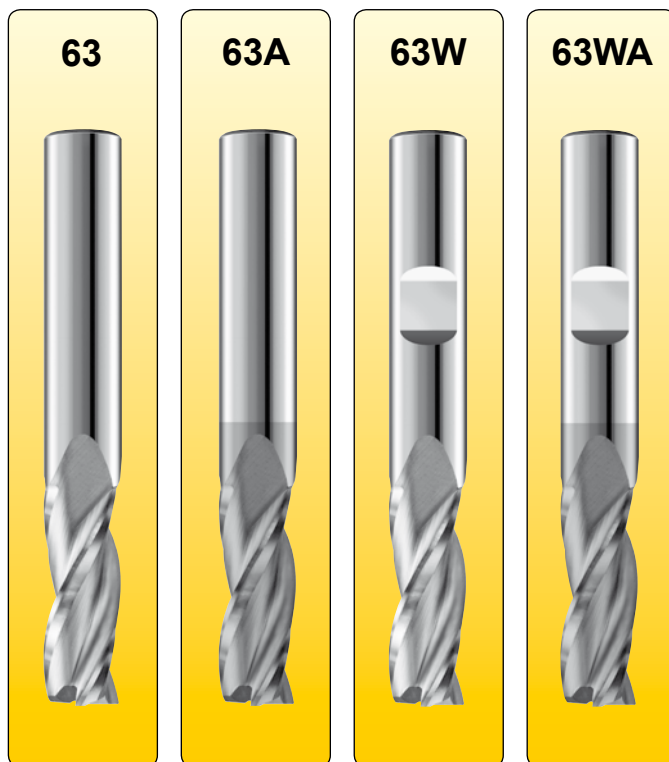

Einsatzgebiete / Range of application

C: Stahlwerkstoffe / Steels
C1.1-1.8 C2.1-2.4 C3.1-3.2 C4.1-4.2

F: Gußeisen / Cast irons
F1.1-1.5 F2.1-2.4

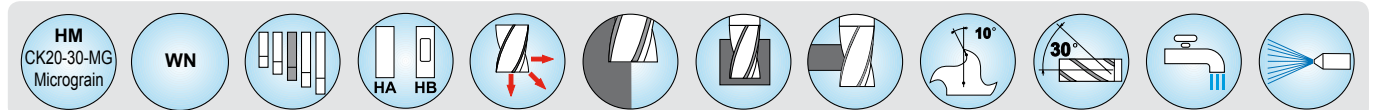
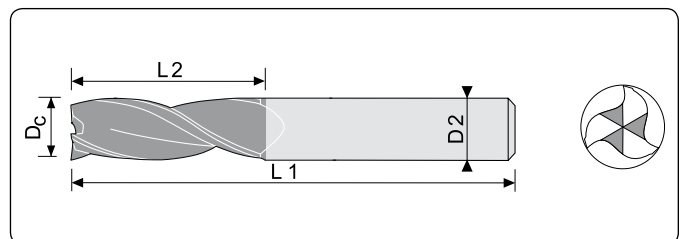

D _c h10	L2	L1	D2 h6	63	63A	63W	63WA
				■	Beschichtet/Coated	■	Beschichtet/Coated
2	6	40	2	63.020020640	63.020020640A		
2	3	50	6	63.020060350	63.020060350A	63W.020060350	63W.020060350A
2,5	7	40	2,5	63.025250740	63.025250740A		
3	7	57	6	63.030060757	63.030060757A	63W.030060757	63W.030060757A
3	10	40	3	63.030031040	63.030031040A		
3,5	10	40	3,5	63.035351040	63.035351040A		
4	8	57	6	63.040060857	63.040060857A	63W.040060857	63W.040060857A
4	11	40	4	63.040041140	63.040041140A		
4,5	11	50	4,5	63.045451150	63.045451150A		
5	13	50	5	63.050051350	63.050051350A		
5,5	13	50	5,5	63.055551350	63.055551350A		
6	10	57	6	63.060061057	63.060061057A	63W.060061057	63W.060061057A
6	16	50	6	63.060061650	63.060061650A	63W.060061650	63W.060061650A
6,5	16	50	6,5	63.065651650	63.065651650A		
7	16	60	7	63.070071660	63.070071660A		
8	16	63	8	63.080081663	63.080081663A	63W.080081663	63W.080081663A
9	19	63	9	63.090091963	63.090091963A		
10	19	72	10	63.100101972	63.100101972A	63W.100101972	63W.100101972A
11	22	72	11	63.110112272	63.110112272A		
12	22	83	12	63.120122283	63.120122283A	63W.120122283	63W.120122283A
13	26	83	13	63.130132683	63.130132683A		
14	22	83	14	63.140142283	63.140142283A	63W.140142283	63W.140142283A
15	26	92	15	63.150152692	63.150152692A		
16	26	92	16	63.160162692	63.160162692A	63W.160162692	63W.160162692A
18	26	92	18	63.180182692	63.180182692A	63W.180182692	63W.180182692A
20	32	104	20	63.2002032104	63.2002032104A	63W.2002032104	63W.2002032104A
25	45	120	25	63.2502545120	63.2502545120A	63W.2502545120	63W.2502545120A

Schafffräser - Z=3 Drall 30° - WN überlang End mills - Z=3 Helix 30° - Internal standard long

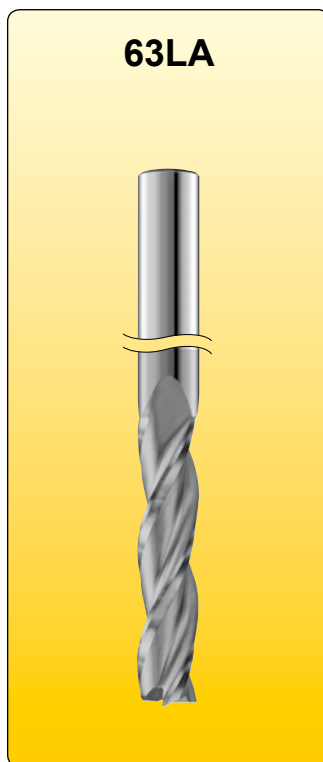
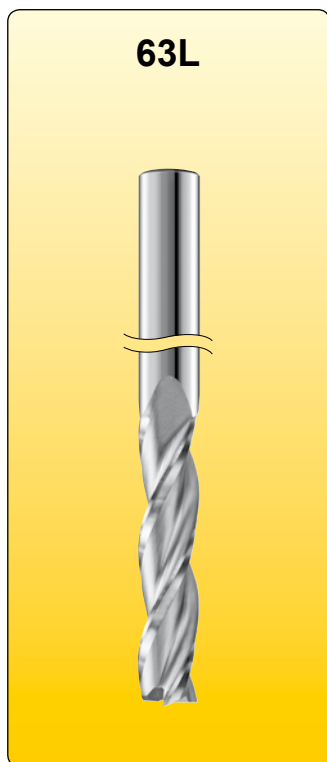

Einsatzgebiete / Range of application

C: Stahlwerkstoffe / Steels
C1.1-1.8 C2.1-2.4 C3.1-3.2 C4.1-4.2

D: Edelstahl / Stainless Steel
D1.1-1.5

F: Gußeisen / Cast irons
F1.1-1.5 F2.1-2.4

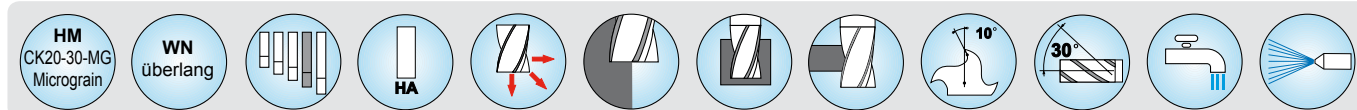
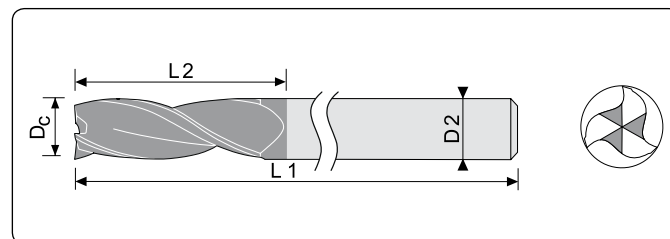

D _c h10	L2	L1	D2 h6	63L	63LA
					Beschichtet / Coated
3	18	60	3	63L.030	63L.030A
4	20	60	4	63L.040	63L.040A
5	25	62	5	63L.050	63L.050A
6	30	70	6	63L.060	63L.060A
8	35	79	8	63L.080	63L.080A
10	40	89	10	63L.100	63L.100A
12	50	100	12	63L.120	63L.120A
14	58	125	14	63L.140	63L.140A
16	58	125	16	63L.160	63L.160A
18	58	125	18	63L.180	63L.180A
20	60	125	20	63L.200	63L.200A

2.
08

Schaftfräser - Z=3 Drall 30° - WN extralang
End mills - Z=3 Helix 30° - Internal standard extra long

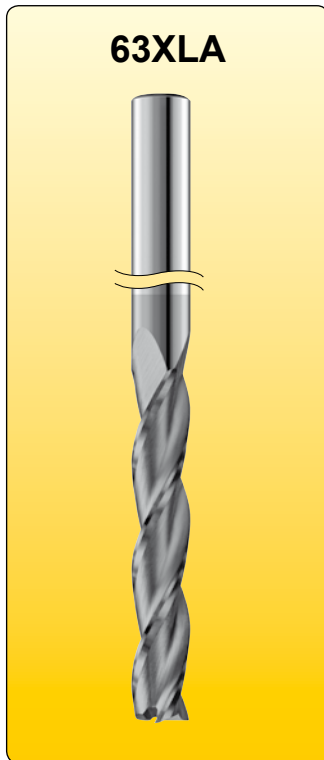
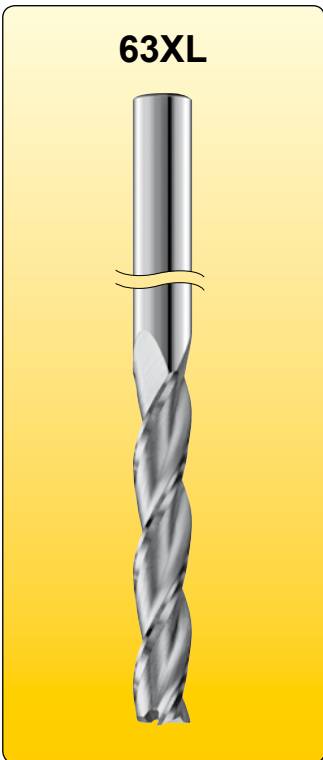

Einsatzgebiete / Range of application

C: Stahlwerkstoffe / Steels
 C1.1-1.8 C2.1-2.4 C3.1-3.2 C4.1-4.2

D: Edelstahl / Stainless Steel
 D1.1-1.5

F: Gußeisen / Cast irons
 F1.1-1.5 F2.1-2.4

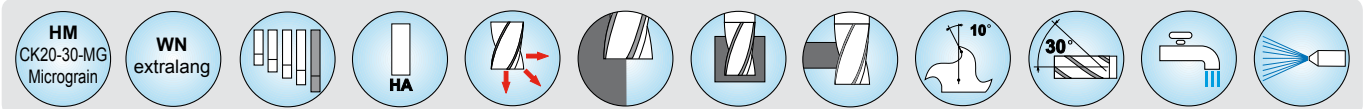
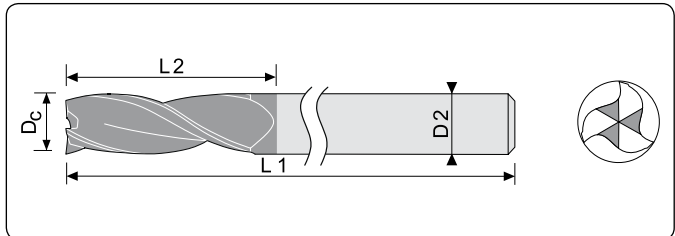

D _c h10	L2	L1	D2 h6	63XL	63XLA
					Beschichtet / Coated
3	25	75	3	63XL.030	63XL.030A
4	32	75	4	63XL.040	63XL.040A
5	38	100	5	63XL.050	63XL.050A
6	40	100	6	63XL.060	63XL.060A
8	45	100	8	63XL.080	63XL.080A
10	50	120	10	63XL.100	63XL.100A
12	60	150	12	63XL.120	63XL.120A
14	75	150	14	63XL.140	63XL.140A
16	75	150	16	63XL.160	63XL.160A
18	75	150	18	63XL.180	63XL.180A
20	75	150	20	63XL.200	63XL.200A

Radiusfräser - Z=3 Drall 30° - WN

Ball nose end mills - Z=3 Helix 30° - Internal standard

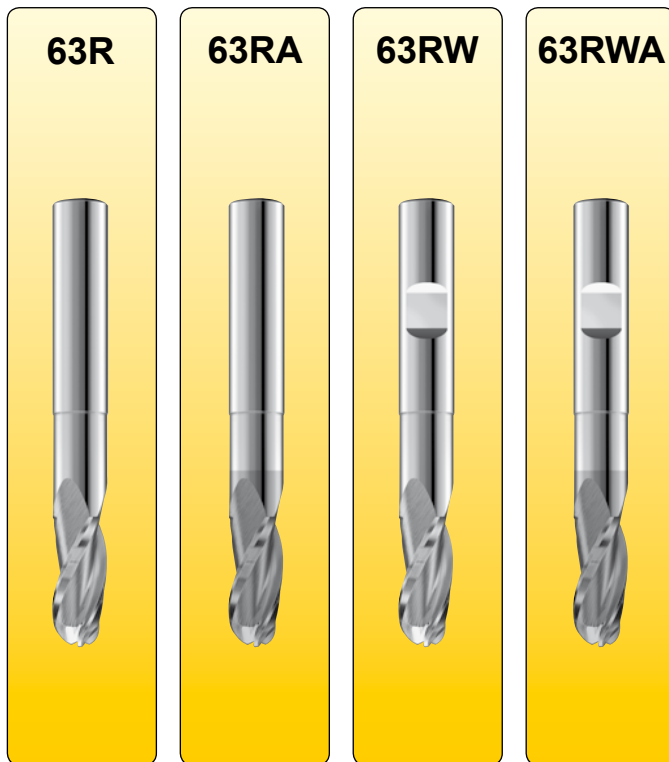

Einsatzgebiete / Range of application

C: Stahlwerkstoffe / Steels
C1.1-1.8 C2.1-2.4 C3.1-3.2 C4.1-4.2

F: Gußeisen / Cast irons
F1.1-1.5 F2.1-2.4

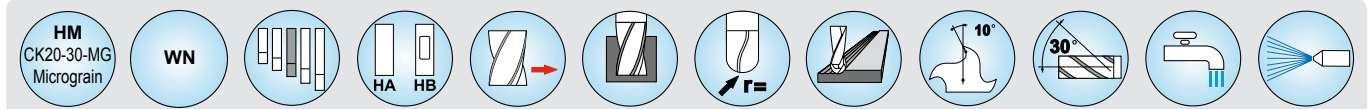
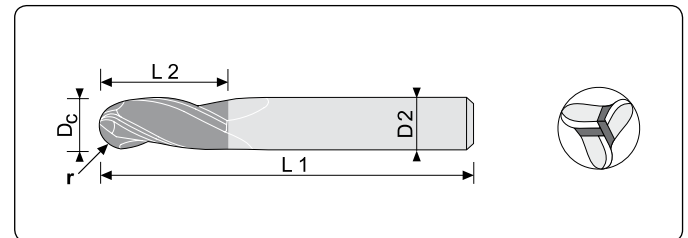

D _c	L ₂	L ₁	D ₂	r	63R	63RA	63RW	63RWA
h10			h6			Beschichtet/Coated		Beschichtet/Coated
2	6	40	2	1	63R.020020640	63R.020020640A		
2,5	7	40	2,5	1,25	63R.025250740	63R.025250740A		
3	7	57	6	1,5	63R.030060757	63R.030060757A	63RW.030060757	63RW.030060757A
3	10	40	3	1,5	63R.030031040	63R.030031040A		
3,5	10	40	3,5	1,75	63R.035351040	63R.035351040A		
4	8	57	6	2	63R.040060857	63R.040060857A	63RW.040060857	63RW.040060857A
4	11	40	4	2	63R.040041140	63R.040041140A		
4,5	11	50	4,5	2,25	63R.045451150	63R.045451150A		
5	13	50	5	2,5	63R.050051350	63R.050051350A		
5,5	13	50	5,5	2,75	63R.055551350	63R.055551350A		
6	10	57	6	3	63R.060061057	63R.060061057A	63RW.060061057	63RW.060061057A
6	16	50	6	3	63R.060061650	63R.060061650A		
7	16	60	7	3,5	63R.070071660	63R.070071660A		
8	16	63	8	4	63R.080081663	63R.080081663A	63RW.080081663	63RW.080081663A
9	19	63	9	4,5	63R.090091963	63R.090091963A		
10	19	72	10	5	63R.100101972	63R.100101972A	63RW.100101972	63RW.100101972A
11	22	72	11	5,5	63R.110112272	63R.110112272A		
12	22	83	12	6	63R.120122283	63R.120122283A	63RW.120122283	63RW.120122283A
14	22	83	14	7	63R.140142283	63R.140142283A	63RW.140142283	63RW.140142283A
16	26	92	16	8	63R.160162692	63R.160162692A	63RW.160162692	63RW.160162692A
18	26	92	18	9	63R.180182692	63R.180182692A	63RW.180182692	63RW.180182692A
20	32	104	20	10	63R.2002032104	63R.2002032104A	63RW.2002032104	63RW.2002032104A
25	45	120	25	12,5	63R.2502545120	63R.2502545120A	63RW.2502545120	63RW.2502545120A

Die Baumasse grösser Ø 12 mm entsprechen DIN 6527-L / Sizes bigger than Ø 12 mm correspond to DIN 6527-L

Radiusfräser - Z=3 Drall 30° - WN überlang

Ball nose end mills - Z=3 Helix 30° - Internal standard long

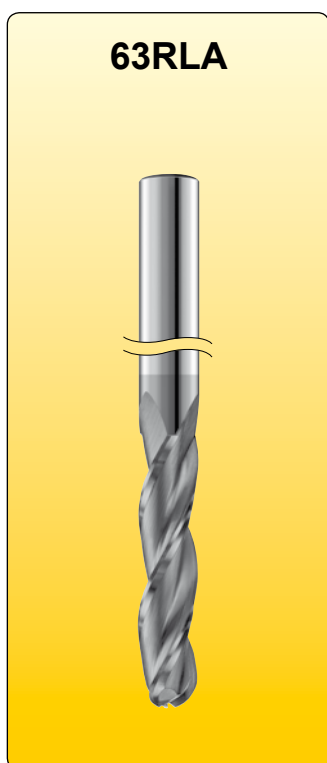
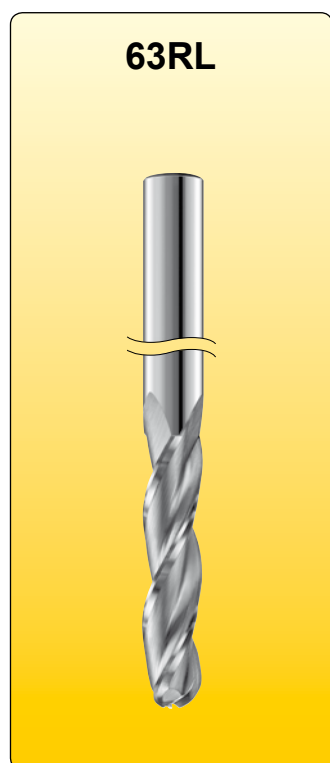

Einsatzgebiete / Range of application

C: Stahlwerkstoffe / Steels

C1.1-1.8 C2.1-2.4 C3.1-3.2 C4.1-4.2

D: Edelstahl / Stainless Steel

D1.1-1.5

F: Gußeisen / Cast irons

F1.1-1.5 F2.1-2.4

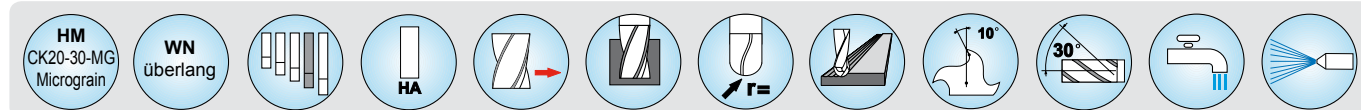
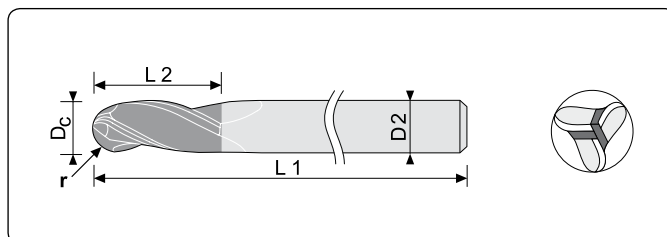

D _c h10	L2	L1	D2 h6	r	63RL	63RLA
						Beschichtet / Coated
3	18	60	3	1,5	63RL.030	63RL.030A
4	20	60	4	2	63RL.040	63RL.040A
5	25	62	5	2,5	63RL.050	63RL.050A
6	30	70	6	3	63RL.060	63RL.060A
8	35	79	8	4	63RL.080	63RL.080A
10	40	89	10	5	63RL.100	63RL.100A
12	50	100	12	6	63RL.120	63RL.120A
14	58	125	14	7	63RL.140	63RL.140A
16	58	125	16	8	63RL.160	63RL.160A
18	58	125	18	9	63RL.180	63RL.180A
20	60	125	20	10	63RL.200	63RL.200A

Radius Schaftfräser - Z=3 Drall 30° - WN extralang
Ball nose end mills - Z=3 Helix 30° - Internal standard extra long

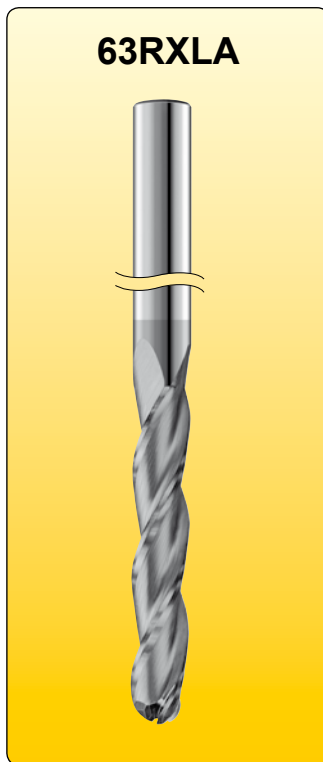
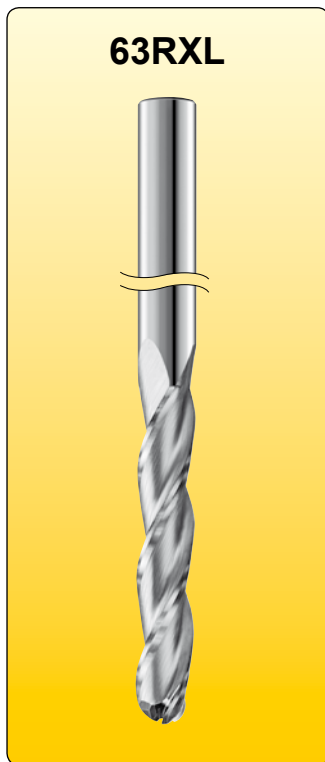

Einsatzgebiete / Range of application

C: Stahlwerkstoffe / Steels
 C1.1-8 C2.1-2.4 C3.1-3.2 C4.1-4.2

D: Edelstahl / Stainless Steel
 D1.1-1.5

F: Gußeisen / Cast irons
 F1.1-1.5 F2.1-2.4

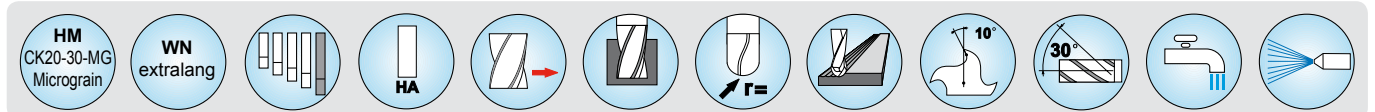
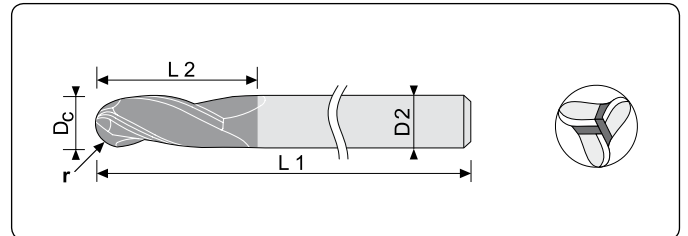

D _c h10	L2	L1	D2 h6	r	63RXL	63RXLA
						Beschichtet / Coated
3	25	75	3	1,5	63RXL.030	63RXL.030A
4	32	75	4	2	63RXL.040	63RXL.040A
5	38	100	5	2,5	63RXL.050	63RXL.050A
6	40	100	6	3	63RXL.060	63RXL.060A
8	45	100	8	4	63RXL.080	63RXL.080A
10	50	120	10	5	63RXL.100	63RXL.100A
12	60	150	12	6	63RXL.120	63RXL.120A
14	75	150	14	7	63RXL.140	63RXL.140A
16	75	150	16	8	63RXL.160	63RXL.160A
18	75	150	18	9	63RXL.180	63RXL.180A
20	75	150	20	10	63RXL.200	63RXL.200A

2.
08

Konische Schafffräser - Z=3 - konstante Spiralsteigung - WN
Taper end mills - Z=3 - constant spiral angle - Internal standard

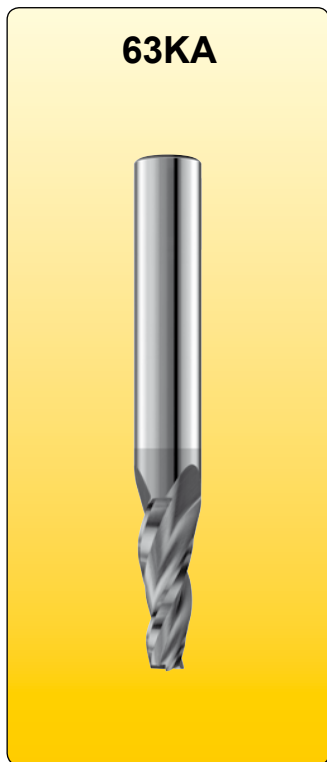
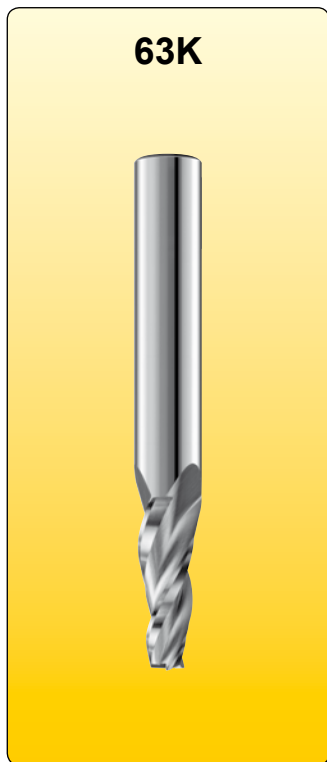

Einsatzgebiete / Range of application

C: Stahlwerkstoffe / Steels
 C1.1-1.8 C2.1-2.4 C3.1-3.2 C4.1-4.2

D: Edelstahl / Stainless Steel
 D1.1-1.5

E: Titan / Titanium
 E2.1 E2.3

F: Gußeisen / Cast irons
 F1.1-1.5 F2.1-2.4

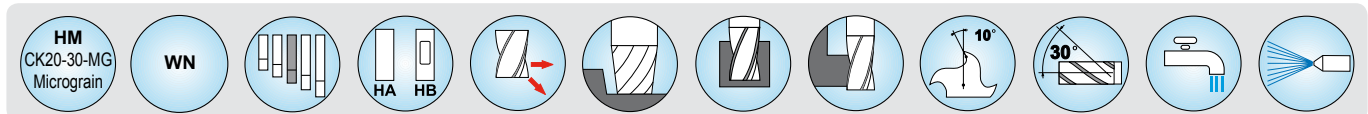
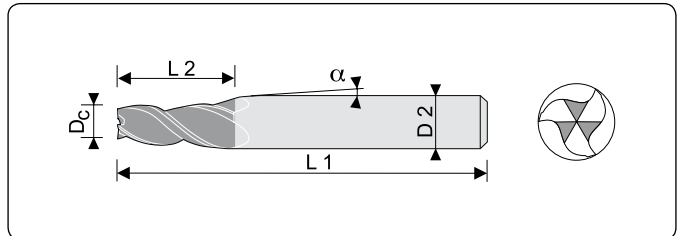

D _c h10	L2	L1	D2 h6	□ α	63K	63KA
						Beschichtet / Coated
4,5	20	57	6	1°	63K.06-1°	63K.06-1°A
6	30	63	8	1°	63K.08-1°	63K.08-1°A
8	30	72	10	1°	63K.10-1°	63K.10-1°A
10	35	83	12	1°	63K.12-1°	63K.12-1°A
12	35	83	14	1°	63K.14-1°	63K.14-1°A
14,5	45	92	16	1°	63K.16-1°	63K.16-1°A
16	55	100	18	1°	63K.18-1°	63K.18-1°A
18	55	104	20	1°	63K.20-1°	63K.20-1°A
2,5	20	57	6	3°	63K.06-3°	63K.06-3°A
4	30	63	8	3°	63K.08-3°	63K.08-3°A
6	30	72	10	3°	63K.10-3°	63K.10-3°A
8	35	83	12	3°	63K.12-3°	63K.12-3°A
10	35	83	14	3°	63K.14-3°	63K.14-3°A
11,3	45	92	16	3°	63K.16-3°	63K.16-3°A
12	55	100	18	3°	63K.18-3°	63K.18-3°A
14,2	55	104	20	3°	63K.20-3°	63K.20-3°A
2,5	20	57	6	5°	63K.06-5°	63K.06-5°A
3	25	63	8	5°	63K.08-5°	63K.08-5°A
3,5	30	72	10	5°	63K.10-5°	63K.10-5°A
4	35	83	12	5°	63K.12-5°	63K.12-5°A
8	35	83	14	5°	63K.14-5°	63K.14-5°A
9	40	92	16	5°	63K.16-5°	63K.16-5°A
11	40	100	18	5°	63K.18-5°	63K.18-5°A
12	45	104	20	5°	63K.20-5°	63K.20-5°A

Konische Radiusfräser - Z=3 - konstante Spiralsteigung - WN Taper ball nose end mills - Z=3 - constant spiral angle - Internal standard

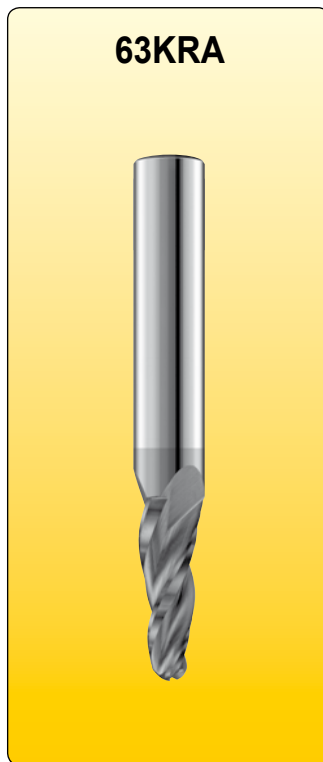
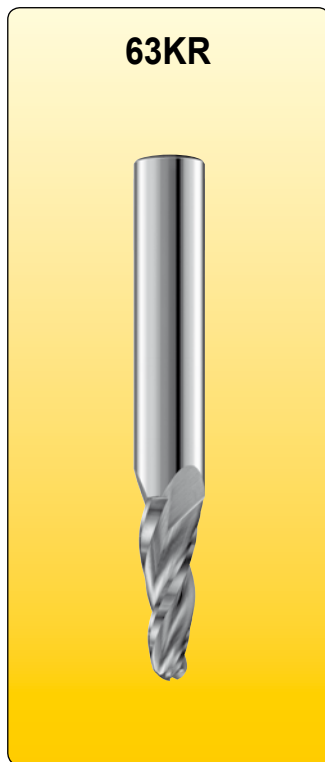

Einsatzgebiete / Range of application

C: Stahlwerkstoffe / Steels
C1.1-1.8 C2.1-2.4 C3.1-3.2 C4.1-4.2

D: Edelstahl / Stainless Steel
D1.1-1.5

E: Titan / Titanium
E2.1 E2.3

F: Gußeisen / Cast irons
F1.1-1.5 F2.1-2.4

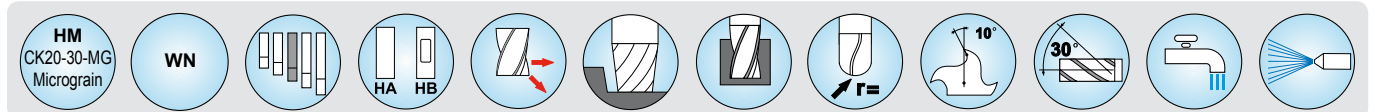
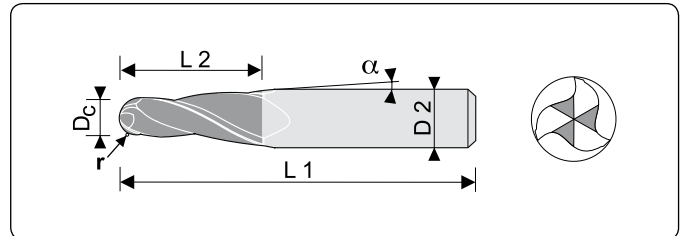

D _c h10	L2	L1	D2 h6	r	□ α	63KR	63KRA
							Beschichtet / Coated
4,5	20	57	6	2,25	1°	63KR.06-1°	63KR.06-1°A
6	30	63	8	3	1°	63KR.08-1°	63KR.08-1°A
8	30	72	10	4	1°	63KR.10-1°	63KR.10-1°A
10	35	83	12	5	1°	63KR.12-1°	63KR.12-1°A
12	35	83	14	6	1°	63KR.14-1°	63KR.14-1°A
14,5	45	92	16	7,25	1°	63KR.16-1°	63KR.16-1°A
16	55	100	18	8	1°	63KR.18-1°	63KR.18-1°A
18	55	104	20	9	1°	63KR.20-1°	63KR.20-1°A
2,5	20	57	6	1,25	3°	63KR.06-3°	63KR.06-3°A
4	30	63	8	2	3°	63KR.08-3°	63KR.08-3°A
6	30	72	10	3	3°	63KR.10-3°	63KR.10-3°A
8	35	83	12	4	3°	63KR.12-3°	63KR.12-3°A
10	35	83	14	5	3°	63KR.14-3°	63KR.14-3°A
11,2	45	92	16	5,6	3°	63KR.16-3°	63KR.16-3°A
12	55	100	18	6	3°	63KR.18-3°	63KR.18-3°A
14	55	104	20	7	3°	63KR.20-3°	63KR.20-3°A
2,5	20	57	6	1,25	5°	63KR.06-5°	63KR.06-5°A
3	25	63	8	1,5	5°	63KR.08-5°	63KR.08-5°A
3,5	30	72	10	1,75	5°	63KR.10-5°	63KR.10-5°A
4	35	83	12	2	5°	63KR.12-5°	63KR.12-5°A
8	35	83	14	4	5°	63KR.14-5°	63KR.14-5°A
9	40	92	16	4,5	5°	63KR.16-5°	63KR.16-5°A
11	40	100	18	5,5	5°	63KR.18-5°	63KR.18-5°A
12	45	104	20	6	5°	63KR.20-5°	63KR.20-5°A



Schaftfräser - mit 4 Schneiden
4 flutes end mills

Schafträser - Z=4 Drall 30° - WN
End mills - Z=4 Helix 30° - Internal standard

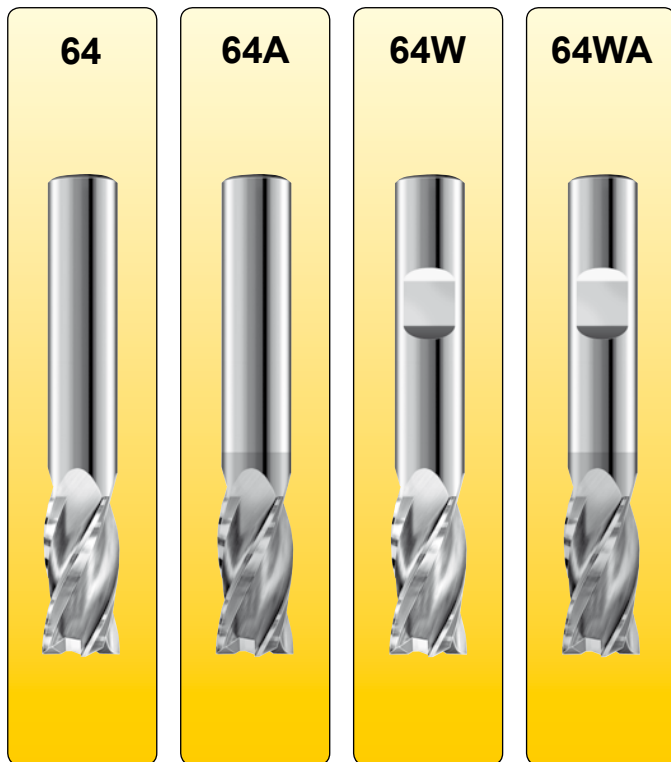

Einsatzgebiete / Range of application

C: Stahlwerkstoffe / Steels
 C1.1-1.8 C2.1-2.4 C3.1-3.2 C4.1-4.2

F: Gußeisen / Cast irons
 F1.1-1.5 F2.1-2.4

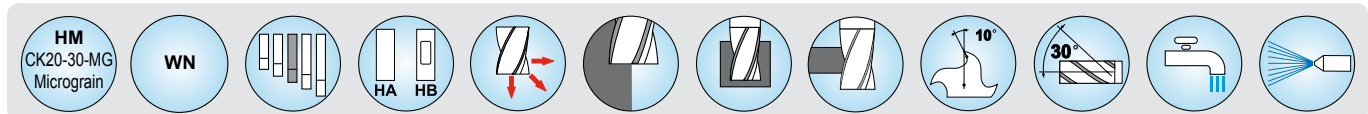
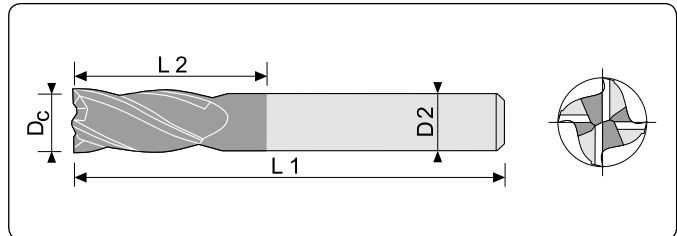

D _c h10	L2	L1	D2 h6	64	64A	64W	64WA
					Beschichtet/Coated		Beschichtet/Coated
2	6	40	2	64.020020640	64.020020640A		
2	4	50	6	64.020060450	64.020060450A		
2,5	7	40	2,5	64.025250740	64.025250740A		
3	8	57	6	64.030060857	64.030060857A	64W.030060857	64W.030060857A
3	10	40	3	64.030031040	64.030031040A		
3,5	10	40	3,5	64.035351040	64.035351040A		
4	11	40	4	64.040041140	64.040041140A		
4	11	57	6	64.040061157	64.040061157A	64W.040061157	64W.040061157A
4,5	11	50	4,5	64.045451150	64.045451150A		
5	13	50	5	64.050051350	64.050051350A		
5,5	13	50	5,5	64.055551350	64.055551350A		
6	13	57	6	64.060061357	64.060061357A	64W.060061357	64W.060061357A
6	16	50	6	64.060061650	64.060061650A		
6,5	16	50	6,5	64.065651650	64.065651650A		
7	16	60	7	64.070071660	64.070071660A		
8	19	63	8	64.080081963	64.080081963A	64W.080081963	64W.080081963A
9	19	63	9	64.090091963	64.090091963A		
10	22	72	10	64.100102272	64.100102272A	64W.100102272	64W.100102272A
11	22	72	11	64.110112272	64.110112272A		
12	26	83	12	64.120122683	64.120122683A	64W.120122683	64W.120122683A
13	26	83	13	64.130132683	64.130132683A		
14	26	83	14	64.140142683	64.140142683A	64W.140142683	64W.140142683A
15	26	92	15	64.150152692	64.150152692A		
16	32	92	16	64.160163292	64.160163292A	64W.160163292	64W.160163292A
18	32	92	18	64.180183292	64.180183292A	64W.180183292	64W.180183292A
20	38	104	20	64.2002038104	64.2002038104A	64W.2002038104	64W.2002038104A
25	45	120	25	64.2502545120	64.2502545120A	64W.2502545120	64W.2502545120A

Schafträser - Z=4 Drall 30° - WN überlang End mills - Z=4 Helix 30° - Internal standard long

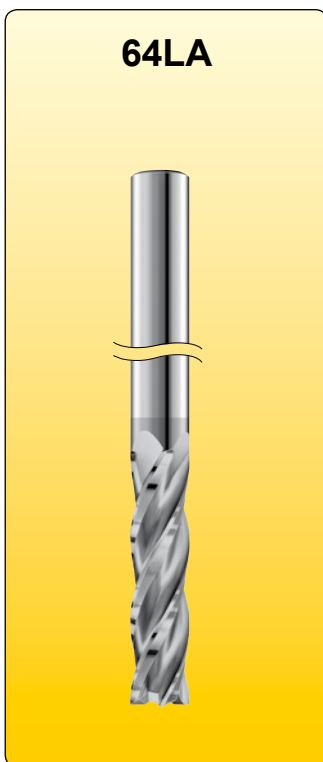
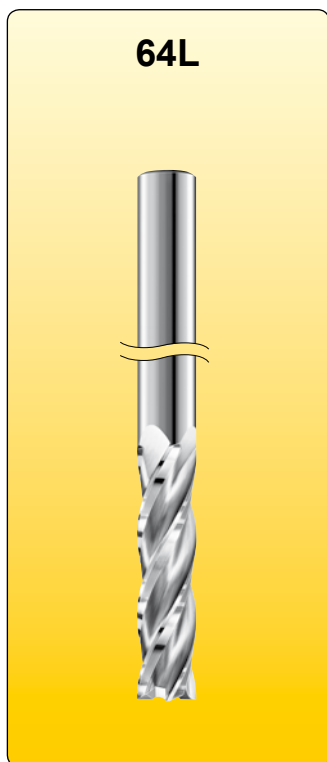

Einsatzgebiete / Range of application

C: Stahlwerkstoffe / Steels
C1.1-1.8 C2.1-2.4 C3.1-3.2 C4.1-4.2

F: Gußeisen / Cast irons
F1.1-1.5 F2.1-2.4

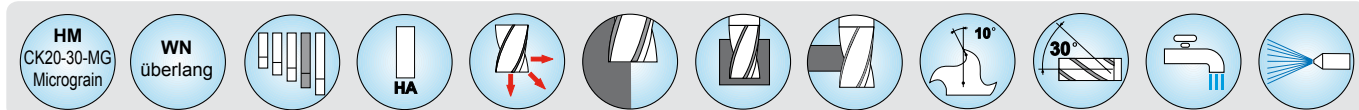
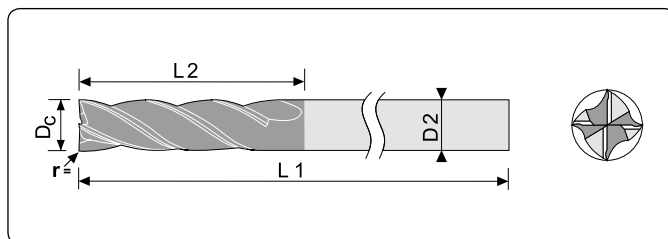

D _c h10	L2	L1	D2 h6	63L	63LA
					Beschichtet / Coated
3	18	60	3	64L.030	64L.030A
4	20	60	4	64L.040	64L.040A
5	25	62	5	64L.050	64L.050A
6	30	70	6	64L.060	64L.060A
8	35	79	8	64L.080	64L.080A
10	40	89	10	64L.100	64L.100A
12	50	100	12	64L.120	64L.120A
14	58	125	14	64L.140	64L.140A
16	58	125	16	64L.160	64L.160A
18	58	125	18	64L.180	64L.180A
20	60	125	20	64L.200	64L.200A

Schaftfräser - Z=4 Drall 30° - WN extralang
End mills - Z=4 Helix 30° - Internal standard extra long

Einsatzgebiete / Range of application

C: Stahlwerkstoffe / Steels
 C1.1-1.8 C2.1-2.4 C3.1-3.2 C4.1-4.2

F: Gußeisen / Cast irons
 F1.1-1.5 F2.1-2.4

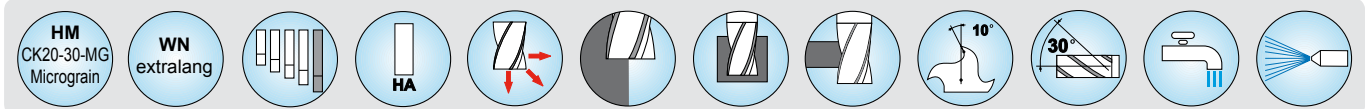
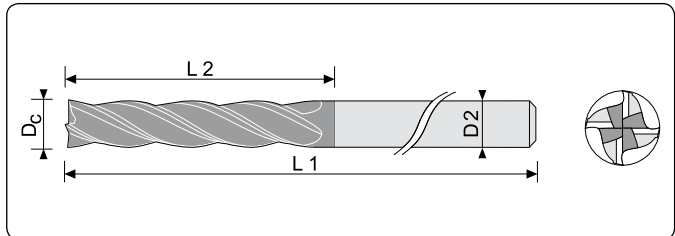
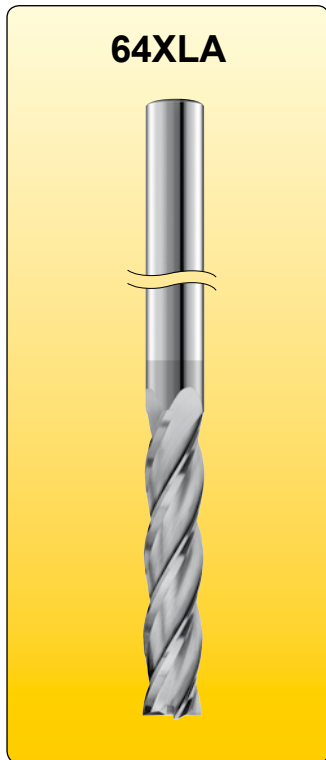
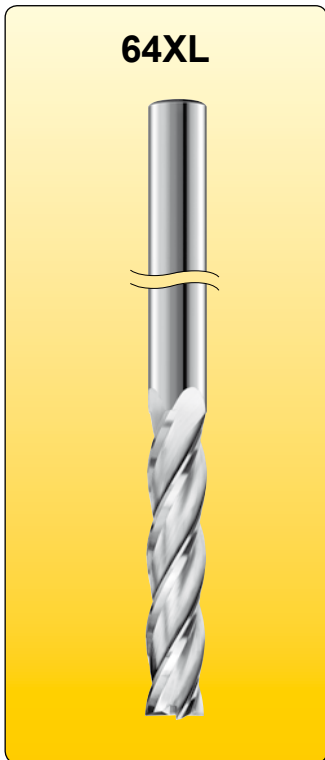

D _c h10	L2	L1	D2 h6	64XL	64XLA
					Beschichtet / Coated
3	25	75	3	64XL.030	64XL.030A
4	32	75	4	64XL.040	64XL.040A
5	38	100	5	64XL.050	64XL.050A
6	40	100	6	64XL.060	64XL.060A
8	45	100	8	64XL.080	64XL.080A
10	50	120	10	64XL.100	64XL.100A
12	60	150	12	64XL.120	64XL.120A
14	75	150	14	64XL.140	64XL.140A
16	75	150	16	64XL.160	64XL.160A
18	75	150	18	64XL.180	64XL.180A
20	75	150	20	64XL.200	64XL.200A

Radius Schaftfräser - Z=4 Drall 30° - WN Ball nose cutters - Z=4 Helix 30° - Internal standard

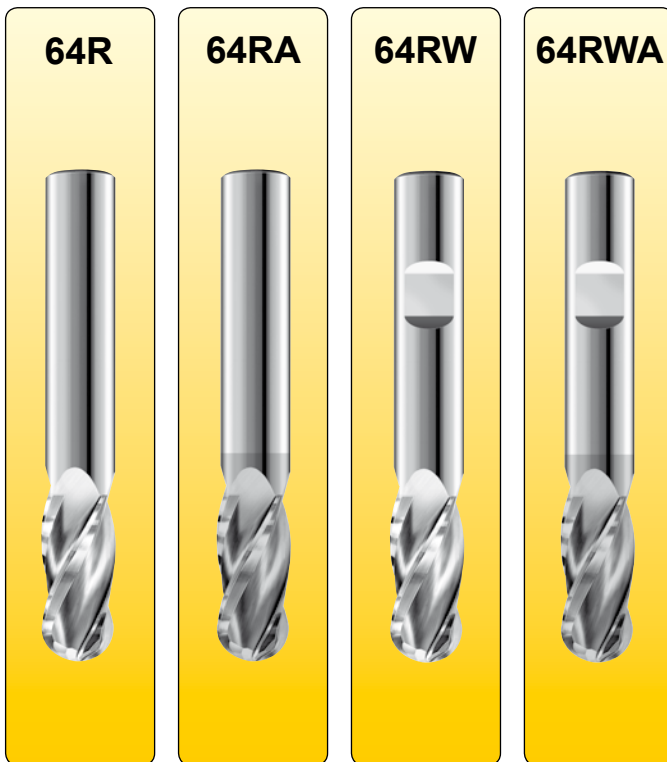

Einsatzgebiete / Range of application

C: Stahlwerkstoffe / Steels
C1.1-1.8 C2.1-2.4 C3.1-3.2 C4.1-4.2

F: Gußeisen / Cast irons
F1.1-1.5 F2.1-2.4

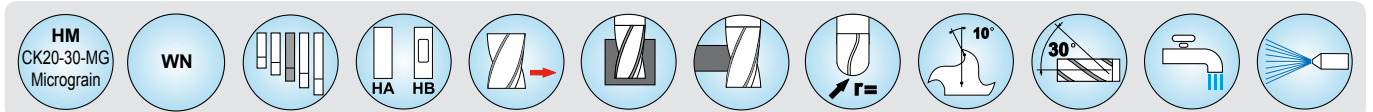
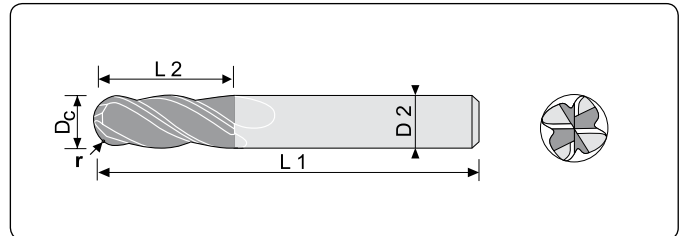

D _c h10	L2	L1	D2 h6	r	64R	64RA	64RW	64RWA
						Beschichtet/Coated		Beschichtet/Coated
2	6	40	2	1	64R.020020640	64R.020020640A		
2,5	7	40	2,5	1,25	64R.025250740	64R.025250740A		
3	8	57	6	1,5	64R.030060857	64R.030060857A	64RW.030060857	64RW.030060857A
3	10	40	3	1,5	64R.030031040	64R.030031040A		
3,5	10	40	3,5	1,75	64R.035351040	64R.035351040A		
4	11	40	4	2	64R.040041140	64R.040041140A		
4	11	57	6	2	64R.040061157	64R.040061157A	64RW.040061157	64RW.040061157A
4,5	11	50	4,5	2,25	64R.045451150	64R.045451150A		
5	13	50	5	2,5	64R.050051350	64R.050051350A		
5,5	13	50	5,5	2,75	64R.055551350	64R.055551350A		
6	13	57	6	3	64R.060061357	64R.060061357A	64RW.060061357	64RW.060061357A
6	16	50	6	3	64R.060061650	64R.060061650A		
6,5	16	50	6,5	3,25	64R.065651650	64R.065651650A		
7	16	60	7	3,5	64R.070071660	64R.070071660A		
8	19	63	8	4	64R.080081963	64R.080081963A	64RW.080081963	64RW.080081963A
9	19	63	9	4,5	64R.090091963	64R.090091963A		
10	22	72	10	5	64R.100102272	64R.100102272A	64RW.100102272	64RW.100102272A
11	22	72	11	5,5	64R.110112272	64R.110112272A		
12	26	83	12	6	64R.120122683	64R.120122683A	64RW.120122683	64RW.120122683A
13	26	83	13	6,5	64R.130132683	64R.130132683A		
14	26	83	14	7	64R.140142683	64R.140142683A	64RW.140142683	64RW.140142683A
15	26	92	15	7,5	64R.150152692	64R.150152692A		

Radius Schaftfräser - Z=4 Drall 30° - WN
Ball nose cutters - Z=4 Helix 30° - Internal standard

D _c h10	L2	L1	D2 h6	r	64R	64RA	64RW	64RWA
						Beschichtet/Coated		Beschichtet/Coated
16	32	92	16	8	64R.160163292	64R.160163292A	64RW.160163292	64RW.160163292A
18	32	92	18	9	64R.180183292	64R.180183292A	64RW.180183292	64RW.180183292A
20	38	104	20	10	64R.2002038104	64R.2002038104A	64RW.2002038104	64RW.2002038104A
25	45	120	25	12,5	64R.2502545120	64R.2502545120A	64RW.2502545120	64RW.2502545120A

Radius Schaftfräser - Z=4 Drall 30° - WN überlang
Ball nose cutters - Z=4 Helix 30° - Internal standard long

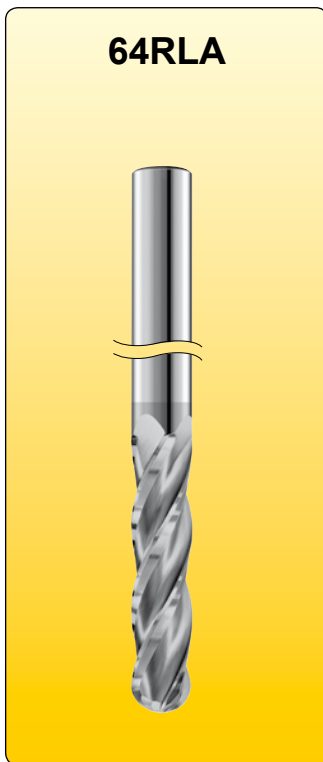
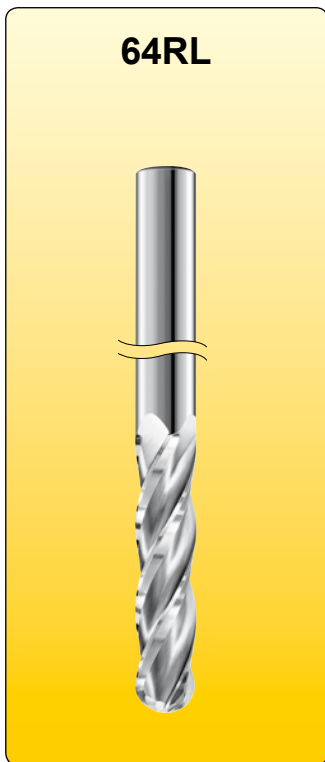

Einsatzgebiete / Range of application

C: Stahlwerkstoffe / Steels
 C1.1-1.8 C2.1-2.4 C3.1-3.2 C4.1-4.2

F: Gußeisen / Cast irons
 F1.1-1.5 F2.1-2.4

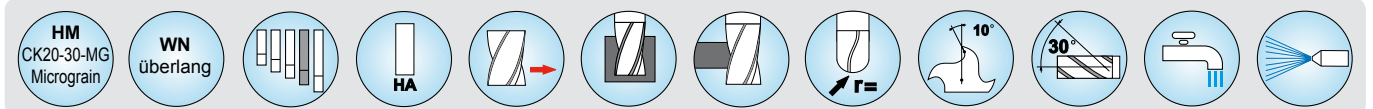
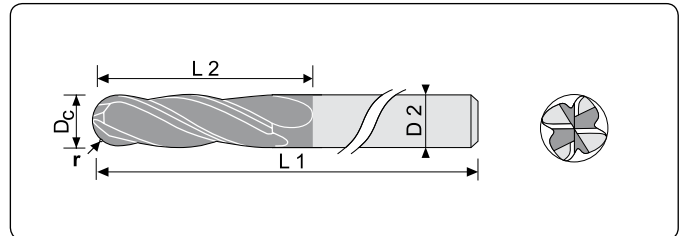

D _c h10	L2	L1	D2 h6	r	64RL	64RLA
						Beschichtet / Coated
3	18	60	3	1,5	64RL.030	64RL.030A
4	20	60	4	2	64RL.040	64RL.040A
5	25	62	5	2,5	64RL.050	64RL.050A
6	30	70	6	3	64RL.060	64RL.060A
8	35	79	8	4	64RL.080	64RL.080A
10	40	89	10	5	64RL.100	64RL.100A
12	50	100	12	6	64RL.120	64RL.120A
14	58	125	14	7	64RL.140	64RL.140A
16	58	125	16	8	64RL.160	64RL.160A
18	58	125	18	9	64RL.180	64RL.180A
20	60	125	20	10	64RL.200	64RL.200A

2.
09

Radius Schaftfräser - Z=4 Drall 30° - WN extralang
Ball nose cutters - Z=4 Helix 30° - Internal standard extra long

Einsatzgebiete / Range of application

C: Stahlwerkstoffe / Steels
 C1.1-1.8 C2.1-2.4 C3.1-3.2 C4.1-4.2

F: Gußeisen / Cast irons
 F1.1-1.5 F2.1-2.4

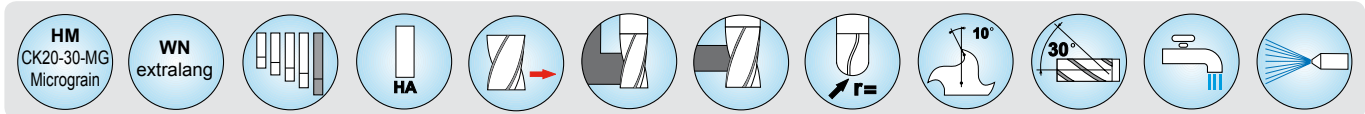
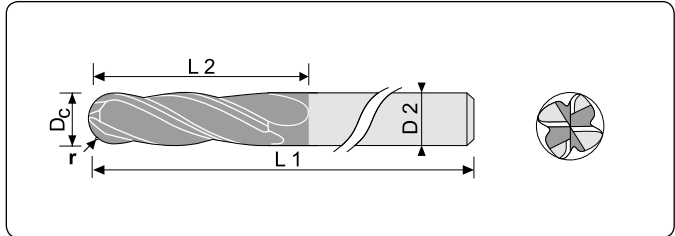
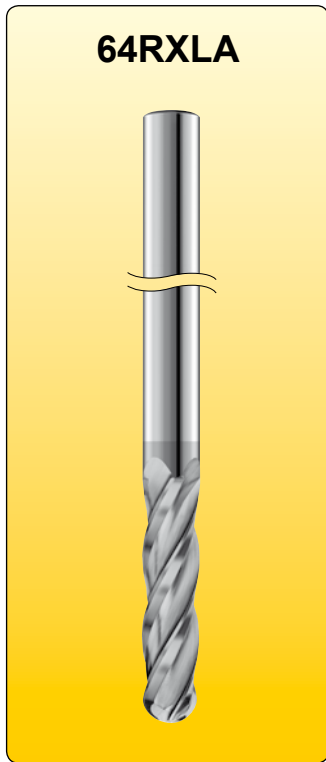
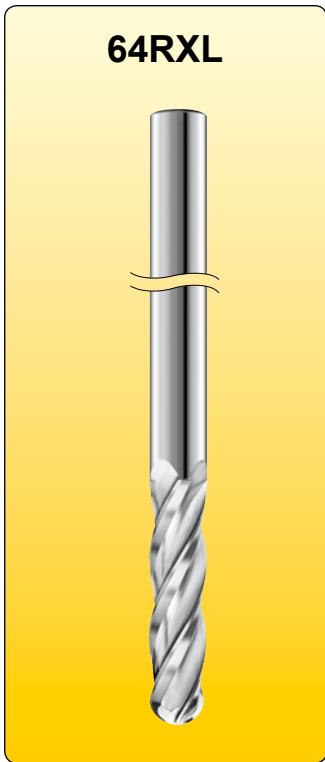

D _c h10	L2	L1	D2 h6	r	64RXL	64RXLA
						Beschichtet / Coated
3	25	75	3	1,5	64RXL.030	64RXL.030A
4	32	75	4	2	64RXL.040	64RXL.040A
5	38	100	5	2,5	64RXL.050	64RXL.050A
6	40	100	6	3	64RXL.060	64RXL.060A
8	45	100	8	4	64RXL.080	64RXL.080A
10	50	120	10	5	64RXL.100	64RXL.100A
12	60	150	12	6	64RXL.120	64RXL.120A
14	75	150	14	7	64RXL.140	64RXL.140A
16	75	150	16	8	64RXL.160	64RXL.160A
18	75	150	18	9	64RXL.180	64RXL.180A
20	75	150	20	10	64RXL.200	64RXL.200A



Mehrschneiden-Schlichtfräser
Multi-flute finishing end mills

Schafffräser - Z=6 Drall 25° - Typ H - WN
End mills - Z=6 Helix 25° - "H" design - Internal standard

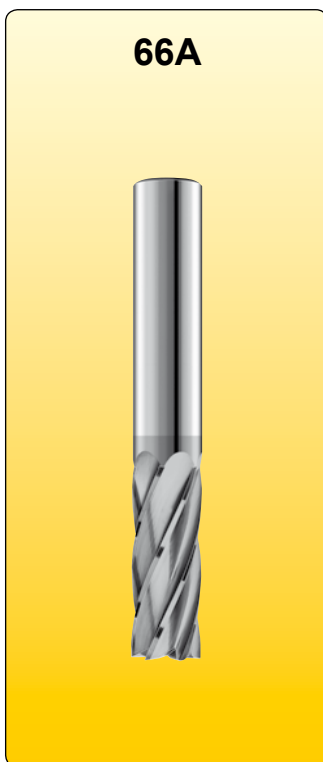
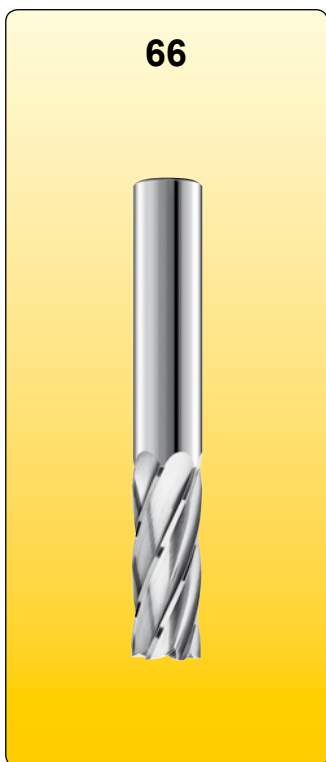

Einsatzgebiete / Range of application

C: Stahlwerkstoffe / Steels
 C1.3-1.8 C2.1-2.4 C3.1-3.2 C4.1-4.2

D: Edelstahl / Stainless Steel
 D1.1-1.5

E: Titan / Titanium
 E2.1 E2.3

F: Gußeisen / Cast irons
 F1.1-1.5 F2.1-2.4

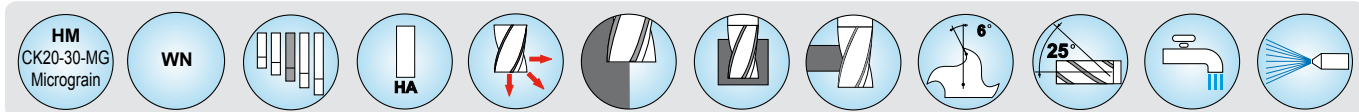
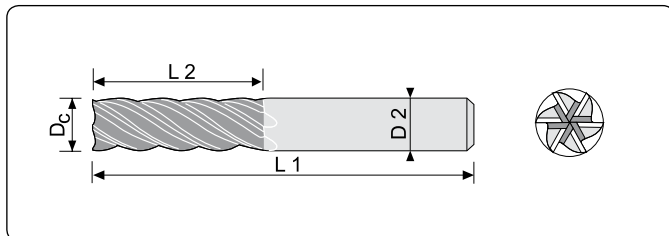

D _c h10	L2	L1	D2 h6	Z	66	66A
					■	Beschichtet / Coated
3	12	40	3	6	66.030	66.030A
4	14	40	4	6	66.040	66.040A
5	18	50	5	6	66.050	66.050A
6	18	50	6	6	66.060	66.060A
7	22	60	7	6	66.070	66.070A
8	25	63	8	6	66.080	66.080A
9	25	63	9	6	66.090	66.090A
10	30	72	10	6	66.100	66.100A
11	30	72	11	6	66.110	66.110A
12	32	83	12	6	66.120	66.120A
14	32	83	14	6	66.140	66.140A
16	36	92	16	6	66.160	66.160A
18	40	92	18	6	66.180	66.180A
20	45	104	20	6	66.200	66.200A

Mehrschneiden-Schlichtfräser - ungerade Schneidenzahl - WN
Multi-flute finishing end mills - uneven number of flutes - Internal standard

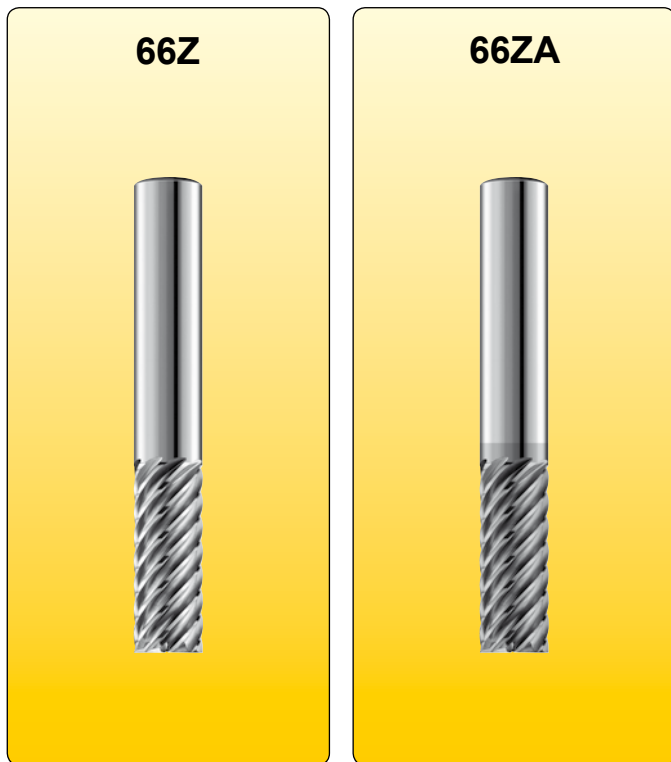

Einsatzgebiete / Range of application

C: Stahlwerkstoffe / Steels
 C1.1-1.8 C2.1-2.4 C3.1 C4.1

D: Edelstahl / Stainless Steel
 D1.1-1.4

E: Titan / Titanium
 E2.1 E2.3

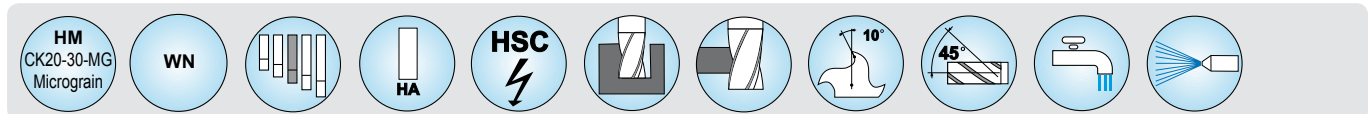
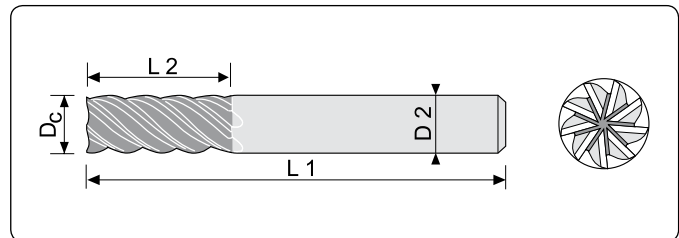

D _c h10	L2	L1	D2 h6	Z	66Z	66ZA
					□	Beschichtet / Coated
4	14	40	4	5	66Z.040	66Z.040A
5	18	50	5	5	66Z.050	66Z.050A
6	18	50	6	7	66Z.060	66Z.060A
8	25	63	8	7	66Z.080	66Z.080A
10	30	72	10	9	66Z.100	66Z.100A
12	32	83	12	9	66Z.120	66Z.120A
14	32	83	14	9	66Z.140	66Z.140A
16	36	92	16	11	66Z.160	66Z.160A
18	40	92	18	11	66Z.180	66Z.180A
20	45	104	20	13	66Z.200	66Z.200A
25	45	120	25	13	66Z.250	66Z.250A

Radius Schaftfräser - engverzahnt mit Spanteiler - WN
Ball nose end mills - Fine cut with chipbreaker - Internal standard

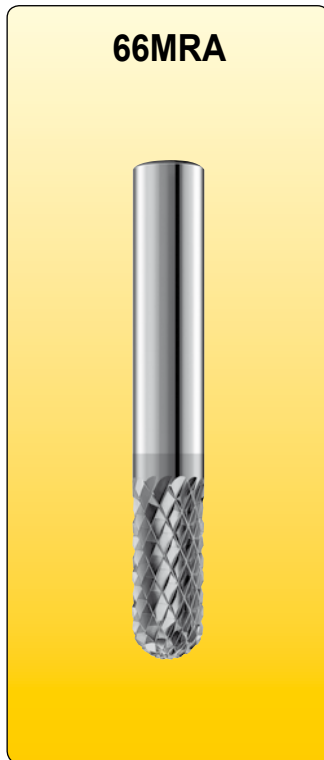

Einsatzgebiete / Range of application

C: Stahlwerkstoffe / Steels
 C1.3-1.8 C2.1-2.4 C3.1-3.2 C4.1-4.2

D: Edelstahl / Stainless Steel
 D1.1-1.4

E: Titan / Titanium
 E2.1 E2.3

F: Gußeisen / Cast irons
 F1.1-1.3 F2.1-2.4

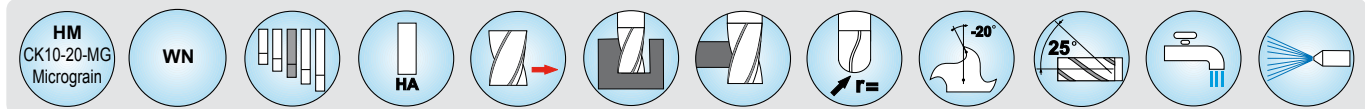
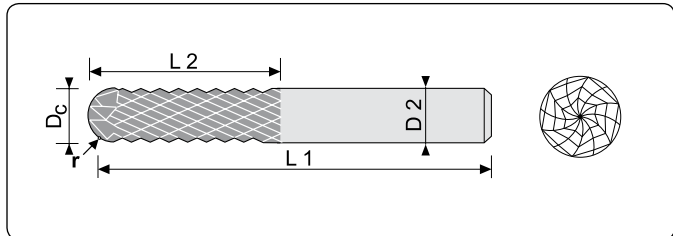

D _c h10	L2	L1	D2 h6	r	66MR	66MRA
					□	Beschichtet / Coated
3	10	40	3	1,5	66MR.030	66MR.030A
4	11	40	4	2	66MR.040	66MR.040A
5	13	50	5	2,2	66MR.050	66MR.050A
6	16	50	6	3	66MR.060	66MR.060A
8	19	63	8	4	66MR.080	66MR.080A
10	22	72	10	5	66MR.100	66MR.100A
12	26	83	12	6	66MR.120	66MR.120A
16	32	92	16	8	66MR.160	66MR.160A
18	18	92	18	9	66MR.180	66MR.180A
20	38	104	20	10	66MR.200	66MR.200A

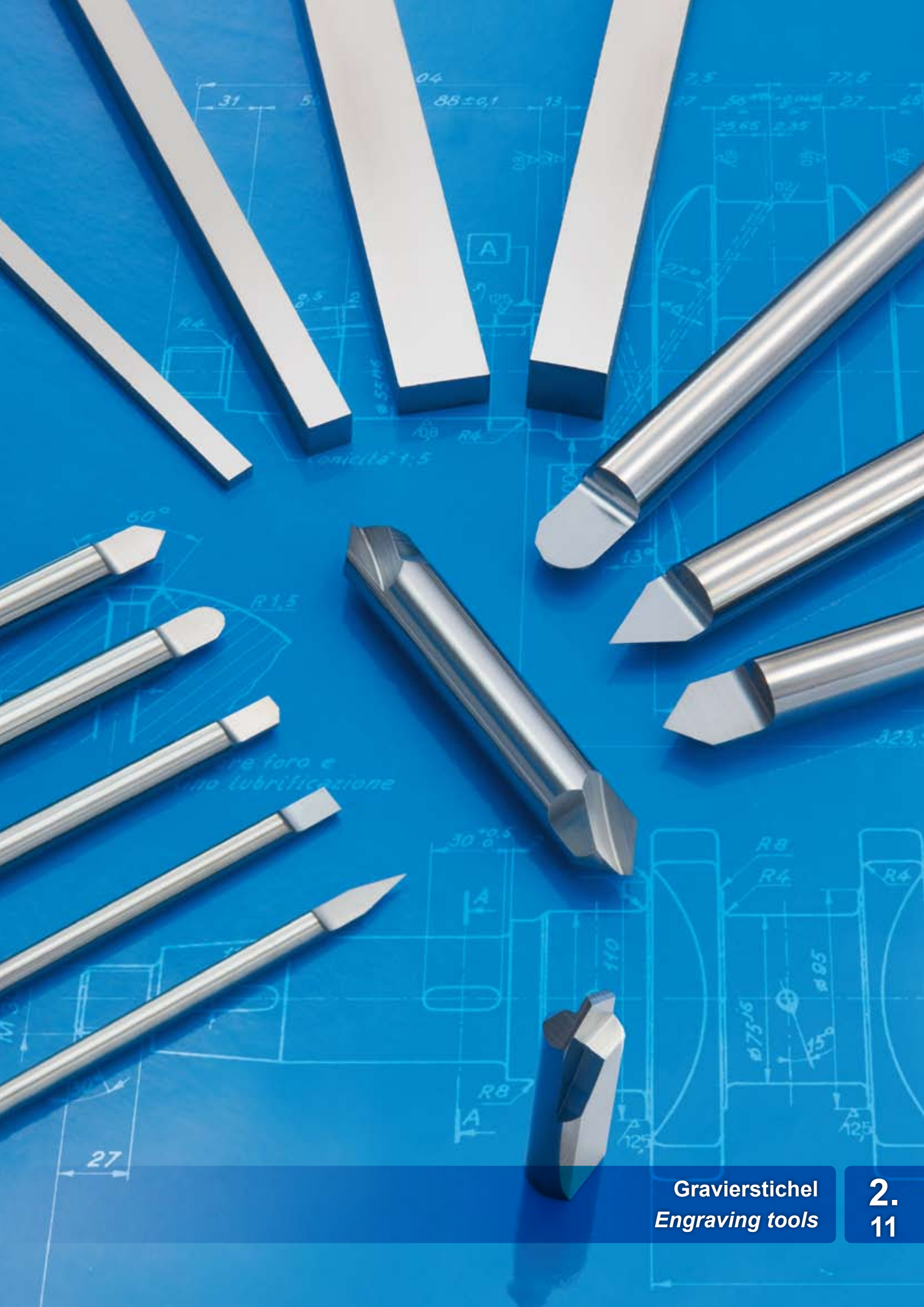

Rundstäbe Round blanks

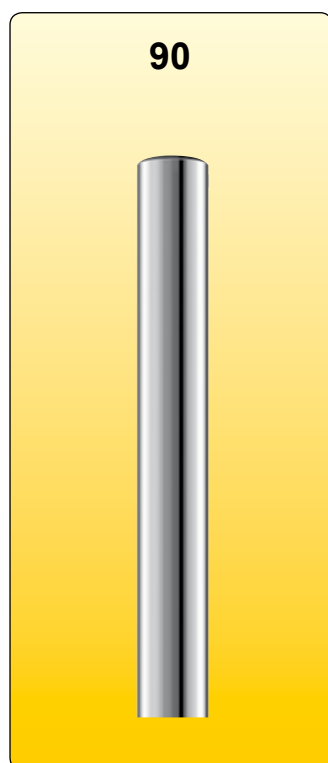

Einsatzgebiete / Range of application

A: Legierungen / Light alloys
A1.1-1.6 A2.1-2.7 A3.1-3.2 A4.1-4.2

C: Stahlwerkstoffe / Steels
C1.1-1.8 C2.1-2.4 C3.1-3.2 C4.1-4.2

D: Edelstahl / Stainless Steel
D1.1-1.5

E: Titan / Titanium
E1.1-1.3 E2.1-2.2

F: Gußeisen / Cast irons
F1.1-1.5 F2.1-2.4

G: Graphit / Graphite
G1.1 G2.1

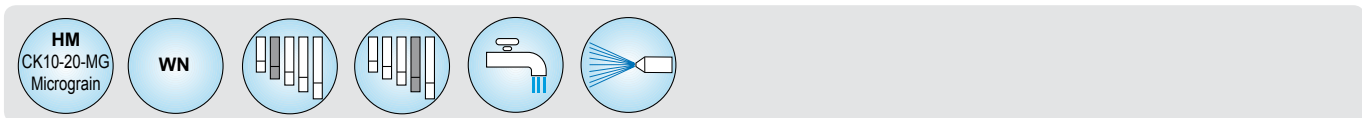
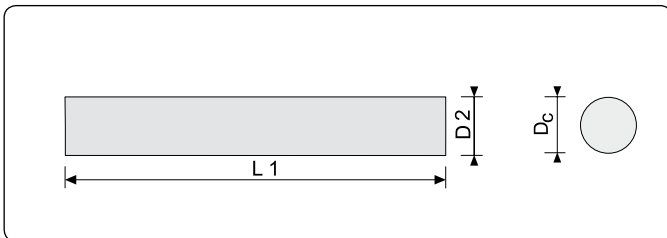

D _c h6	L1	D2 h6	90
2	40	2	90.02040
2	100	2	90.020100
2,5	40	2,5	90.02540
2,5	100	2,5	90.025100
3	50	3	90.03050
3	100	3	90.030100
4	55	4	90.04055
4	100	4	90.040100
5	62	5	90.05062
5	100	5	90.050100
6	66	6	90.06066
6	100	6	90.060100
8	79	8	90.08079
8	100	8	90.080100
10	100	10	90.100100
12	100	12	90.120100
14	100	14	90.140100
16	100	16	90.160100
18	100	18	90.180100
20	100	20	90.200100

Gravierstichel einseitig vorprofiliert
Engraving tool preshaped on one side

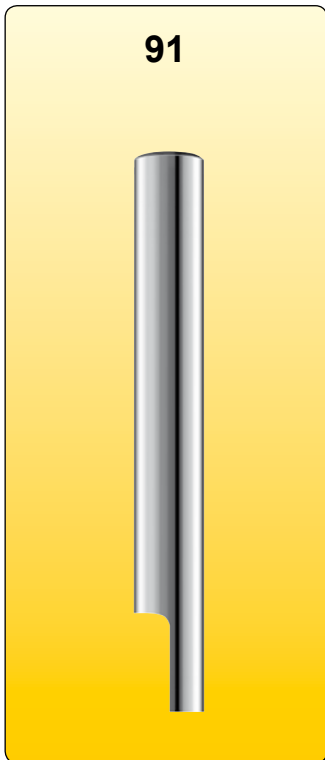

Einsatzgebiete / Range of application

- A: Legierungen / Light alloys
A1.1-1.6 A2.1-2.7 A3.1-3.2 A4.1-4.2
- C: Stahlwerkstoffe / Steels
C1.1-1.8 C2.1-2.4 C3.1-3.2 C4.1-4.2
- D: Edelstahl / Stainless Steel
D1.1-1.5
- E: Titan / Titanium
E1.1-1.3 E2.1-2.2
- F: Gußeisen / Cast irons
F1.1-1.5 F2.1-2.4
- G: Graphit / Graphite
G1.1 G2.1

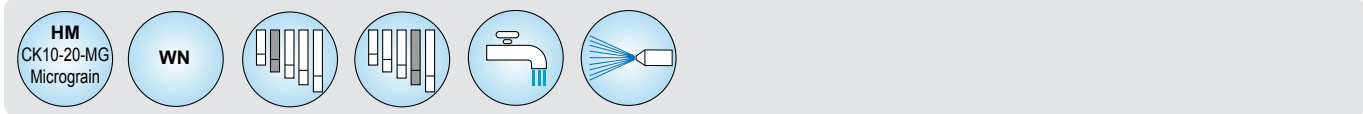
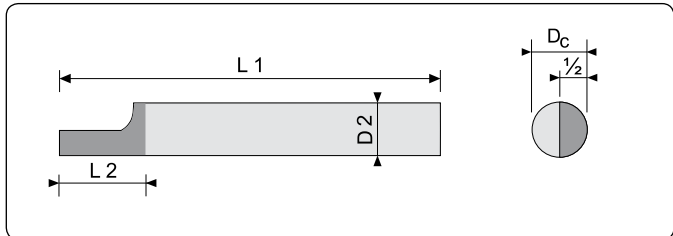

D _c h6	L2	L1	D2 h6	91
2	3	40	2	91.02040
2	3	100	2	91.020100
2,5	3	40	2,5	91.02540
2,5	3	100	2,5	91.025100
3	4	50	3	91.03050
3	4	100	3	91.030100
4	5	55	4	91.04055
4	5	100	4	91.040100
5	6	62	5	91.05062
5	6	100	5	91.050100
6	7	66	6	91.06066
6	7	100	6	91.060100
8	9	79	8	91.08079
8	9	100	8	91.080100
10	11	100	10	91.100100
12	13	100	12	91.120100

Gravierstichel - einseitig profiliert 90° - 60°
Engraving tool 90° - 60° shaped on one side

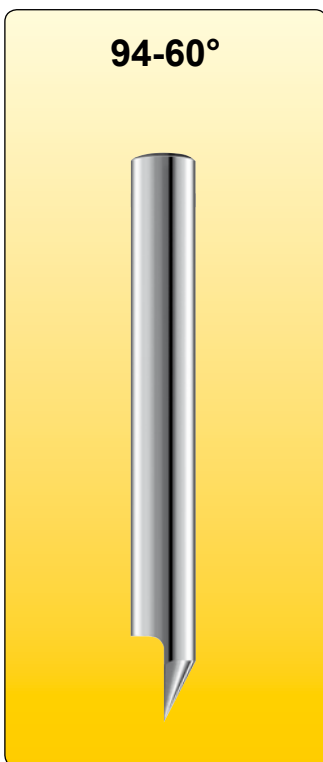
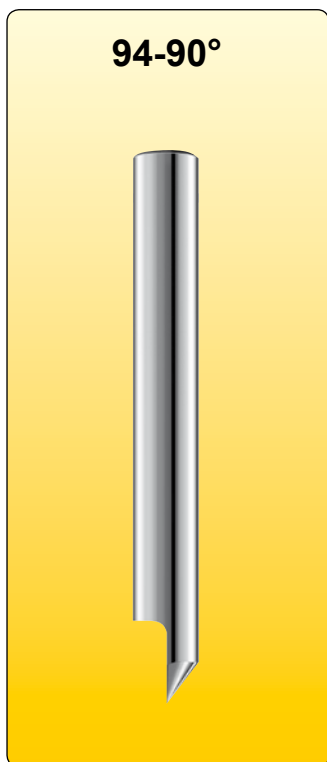

Einsatzgebiete / Range of application

A: Legierungen / Light alloys
 A1.1-1.6 A2.1-2.7 A3.1-3.2 A4.1-4.2

C: Stahlwerkstoffe / Steels
 C1.1-1.8 C2.1-2.4 C3.1-3.2 C4.1-4.2

D: Edelstahl / Stainless Steel
 D1.1-1.5

E: Titan / Titanium
 E1.1-1.3 E2.1-2.2

F: Gußeisen / Cast irons
 F1.1-1.5 F2.1-2.4

G: Graphit / Graphite
 G1.1 G2.1

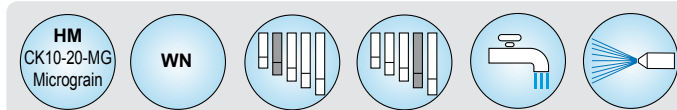
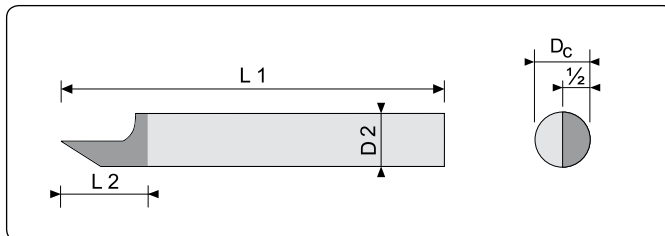

D _c h6	L2	L1	D2 h6	94-90°	94-60°
2	3	40	2	94.02040-90°	94.02040-60°
3	4	50	3	94.03050-90°	94.03050-60°
3	4	100	3	94.030100-90°	94.030100-60°
4	5	55	4	94.04055-90°	94.04055-60°
4	5	100	4	94.040100-90°	94.040100-60°
5	6	62	5	94.05062-90°	94.05062-60°
6	7	66	6	94.06066-90°	94.06066-60°
6	7	100	6	94.060100-90°	94.060100-60°
8	9	79	8	94.08079-90°	94.08079-60°
8	9	100	8	94.080100-90°	94.080100-60°
10	11	100	10	94.100100-90°	94.100100-60°
12	13	100	12	94.120100-90°	94.120100-60°

Vierkantstäbe flach
Rectangular blanks

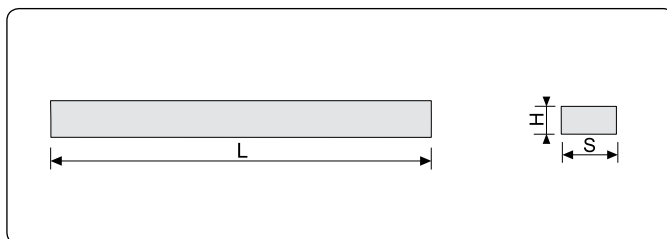
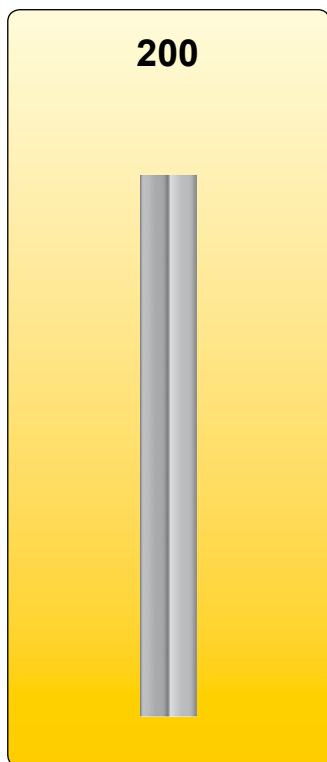

H mm	S mm	L mm	200	
4	2	100		200.0204
5	2	100		200.0205
6	2	100		200.0206
8	2	100		200.0208
10	2	100		200.0210
12	2	100		200.0212
6	3	100		200.0306
8	3	100		200.0308
10	3	100		200.0310
12	3	100		200.0312
8	4	100		200.0408
10	4	100		200.0410
12	4	100		200.0412
10	5	100		200.0510
12	5	100		200.0512
16	5	100		200.0516
8	6	100		200.0608
10	6	100		200.0610
12	6	100		200.0612
16	6	100		200.0616
10	8	100		200.0810
12	8	100		200.0812
16	8	100		200.0816
20	8	100		200.0820

Inhaltsverzeichnis

Index

Werkzeug Gruppe 3: Bohrwerkzeuge	Tools Group 3: Drills	Id. Nr. Code	Seite Page
Einführung	<i>Introduction</i>		230 ÷ 237

Werkzeug Gruppe 3.1:	Tools Group 3.1:	Id. Nr. Code	Seite Page
Zentrierbohrer - Form A - 60°	<i>Center drills - Form A - 60°</i>	171 171F	238
NC-Anbohrer - 90° - 120° - Typ N - WN	<i>90°/120° spotting drills - "N" design - Internal standard</i>	170-90° 170-90°F 170-120° 170-120°F	239

03

Werkzeug Gruppe 3.2:	Tools Group 3.2:	Id. Nr. Code	Seite Page
VHM-Kurzstufenbohrer 90°, für Kernloch plus Senkung zum Gewindegewinden	<i>Short solid carbide 90° step drill, for core hole plus countersink for machine tapping</i>	181 181F	240
VHM-Kurzstufenbohrer 90°, für Kernloch plus Senkung zum Gewindeformen	<i>Short solid carbide 90° step drill, for core hole plus countersink for thread forming</i>	182 182F	241

Werkzeug Gruppe 3.2:	Tools Group 3.2:	Id. Nr. Code	Seite Page
Kombi Bohr- Reibwerkzeug-für faserverstärkte Kunststoffe - WN "DUO-K"	<i>Combi drilling/reaming tool for reinforced plastic fibres - Internal standard</i> "DUO-K"	117 117D	242
Kombi Bohr- Reibwerkzeug-für faserverstärkte Kunststoffe - WN Z=4 "DUO-K"	<i>Combi drilling/reaming tool for reinforced plastic fibres - Internal standard Z=4</i> "DUO-K"	217 217D	243
Spezial - Kevlarbohrer - WN	<i>Drills for KEVLAR</i> - Internal standard	118 118E	244
Bohrer - geradegenutet - DIN 6539	<i>2 straight flute drills</i> - DIN 6539	150 150F	245
Sternbohrer - gerade genutet - DIN 6539	<i>Star drills straight flute</i> - DIN 6539	162 162F	246
Spiralbohrer - 3 Schneiden - DIN 6539	<i>3 flute twist drills</i> - DIN 6539	163 163F	248
Spiralbohrer - Standardgeometrie - DIN 6539	<i>2 flute twist drills</i> - DIN 6539	160 160F	250
Spiralbohrer - Standardgeometrie - lang DIN 338	<i>2 flute twist drills</i> - long according to DIN 338	161 161F	252
Spiralbohrer - für Guss und Leichtmetall - DIN 6539	<i>Twist drills for cast iron and light alloys</i> - DIN 6539	165 165F	254

Spiralbohrer - für Guss und Leichtmetall - lang DIN 338	<i>Twist drills for cast iron and light alloys - long according to DIN 338</i>	166 166F	256
Hochleistungs-Spiralbohrer - selbstzentrie- rend - DIN 6539	<i>High performance twist drills-self centering - DIN 6539</i>	172 172F	258
Hochleistungs-Spiralbohrer - selbstzentrie- rend - WN	<i>High performance twist drills-self centering - WN</i>	173 173F	260
Hochleistungs-Spiralbohrer-mit Kühlkanä- len-selbstzentrierend-kurz DIN 6537-K	<i>High performance twist drills with coolant ducts-self centering-short acc. to DIN 6537-K</i>	175 175F	262
Hochleistungs-Spiralbohrer - mit Kühlkanä- len - selbstzentrierend - lang DIN 6537-L	<i>High performance twist drills with coolant ducts-self centering-long acc. to DIN 6537-L</i>	176 176F	264



Schnittgeschwindigkeit V_c (m/min)
Cutting speed V_c (m/min)

	◆	f (mm)	171	170-90°	181	182	117	217	118	150	162	162L	163
			171F	170-90°F	181F	182F	117D	217D	118E	150F	162F	162LF	163F
V_c (m/min) - für Bohrer ohne Beschichtung V_c (m/min) - for drills without coating													
Aluminium - Alu-Legierungen - Kupfer - Kupferlegierungen - Magnesium Aluminium - Alu-alloys - Copper - Copper alloys - Magnesium													
A 1.1	1	K	130	130	130	130	-	-	-	150	-	-	130
A 1.2	1	K	140	140	140	140	-	-	-	-	-	-	150
A 1.3	1	H	130	130	130	130	-	-	-	150	-	-	-
A 1.4	1	H	100	100	100	100	-	-	-	-	-	-	100
A 1.5	1	K	130	130	130	130	-	-	-	150	-	-	120
A 1.6	1	H	160	160	160	160	-	-	-	-	-	-	120
A 1.7	3	C	50	50	50	50	-	-	-	-	50	42	60
A 2.1	1	G	70	70	70	70	-	-	-	-	-	-	85
A 2.2	1	G	70	70	70	70	-	-	-	85	-	-	85
A 2.3	2	F	70	70	70	70	-	-	-	90	-	-	90
A 2.4	2	E	70	70	70	70	-	-	-	-	-	-	90
A 2.5	1	H	150	150	150	150	-	-	-	180	-	-	200
A 2.6	1	G	100	100	100	100	-	-	-	-	-	-	100
A 2.7	2	F	60	60	60	60	-	-	-	70	-	-	70
A 3.1	1	E	70	70	70	70	-	-	-	-	-	-	70
A 3.2	1	E	70	70	70	70	-	-	-	-	-	-	70
A 4.1	3	G	*150	*150	*150	*150	-	-	-	-	-	-	*180
A 4.2	3	G	*150	*150	*150	*150	-	-	-	*120	-	-	*180
Allgemeine Stahlwerkstoffe - Stahlegierungen - gehärtete Stähle General - Construction steels - Steel alloys - Hardened steels													
C 1.1	1	G	90	90	90	90	-	-	-	-	-	-	100
C 1.2	1	G	90	90	90	90	-	-	-	-	-	-	100
C 1.3	1	G	85	85	85	85	-	-	-	-	-	-	100
C 1.4	1	G	80	80	80	80	-	-	-	90	90	76	90
C 1.5	1	G	90	90	90	90	-	-	-	100	100	85	100
C 1.6	1	G	80	80	80	80	-	-	-	90	90	76	90
C 1.7	1	G	60	60	60	60	-	-	-	70	70	60	70
C 1.8	1	G	80	80	80	80	-	-	-	90	90	76	90
C 2.1	1	E	65	65	65	65	-	-	-	45	45	38	45
C 2.2	1	E	40	40	40	40	-	-	-	45	45	38	45
C 2.3	2	C	40	40	40	40	-	-	-	45	45	38	45
C 2.4	2	B	50	50	50	50	-	-	-	50	60	51	60
C 3.1	1	B	30	30	30	30	-	-	-	-	40	34	40
C 3.2	2	A	25	25	25	25	-	-	-	-	30	25	30
C 3.3	2	A	-	-	-	-	-	-	-	-	25	21	25
C 3.4	2	A	-	-	-	-	-	-	-	-	-	-	25
C 3.5	2	A	-	-	-	-	-	-	-	-	-	-	20
C 4.1	2	C	35	35	35	35	-	-	-	-	40	34	40
C 4.2	2	C	25	25	25	25	-	-	-	-	30	25	30

Kühlmedium **1 = Emulsion** **2 = Öl** **3 = Luft (*3 = nur Luft ohne Zusätze)**
Coolant **1= emulsion** **2 = oil** **3 = air (*3 = only air without additives)**

◆ **Kühlmedium**
Coolant

Schnittgeschwindigkeit V_c (m/min)
Cutting speed V_c (m/min)

	◆	f (mm)	164	160	161	165	166	172	Code	174	174L	175	176	177
			164F	160F	161F	165F	166F	172F	f (mm)	174F	174LF	175F	176F	177F
			V_c (m/min) - für Bohrer ohne Beschichtung V_c (m/min) - for drills without coating											
Aluminium - Alu-Legierungen - Kupfer - Kupferlegierungen - Magnesium														
Aluminium - Alu-alloys - Copper - Copper alloys - Magnesium														
A 1.1	1	K	130	150	130	160	140	130	K	150	127	220	220	220
A 1.2	1	K	140	170	140	200	170	140	K	170	144	220	220	220
A 1.3	1	H	130	150	130	160	140	130	K	150	127	200	200	200
A 1.4	1	H	80	130	100	150	110	80	K	130	110	170	170	170
A 1.5	1	K	140	150	130	160	140	140	K	150	127	200	200	200
A 1.6	1	H	160	180	160	200	170	160	K	180	153	220	220	220
A 1.7	3	C	-	60	50	-	-	-	D	70	59	-	-	-
A 2.1	1	G	80	85	70	90	75	80	G	85	72	100	100	100
A 2.2	1	G	80	85	70	90	75	80	G	85	72	100	100	100
A 2.3	2	F	90	90	70	-	-	90	G	90	76	100	100	100
A 2.4	2	E	90	90	70	100	80	90	F	90	76	100	100	100
A 2.5	1	H	140	180	150	-	-	140	H	180	153	250	250	250
A 2.6	1	G	130	130	100	110	100	130	G	130	110	180	180	180
A 2.7	2	F	60	70	60	80	70	60	F	70	59	100	100	100
A 3.1	1	E	80	85	70	90	80	80	F	85	72	100	100	100
A 3.2	1	E	80	85	70	70	60	80	F	85	72	100	100	100
A 4.1	3	G	*180	*180	*150	*200	*170	*180	H	*180	*153	*220	*220	*220
A 4.2	3	G	*180	*180	*150	*200	*170	*180	H	*180	*153	*220	*220	*220
Allgemeine Stahlwerkstoffe - Stahllegierungen - gehärtete Stähle														
General - Construction steels - Steel alloys - Hardened steels														
C 1.1	1	G	-	100	90	100	90	-	G	110	93	120	120	120
C 1.2	1	G	-	100	90	100	90	-	G	110	93	120	120	120
C 1.3	1	G	-	100	85	90	75	-	H	100	85	140	140	140
C 1.4	1	G	-	90	80	80	70	-	H	90	76	100	100	100
C 1.5	1	G	-	100	90	90	75	-	G	110	93	120	120	120
C 1.6	1	G	-	90	80	70	60	-	H	100	85	110	110	110
C 1.7	1	G	-	70	60	-	-	-	G	75	63	90	90	90
C 1.8	1	G	-	90	80	-	-	-	H	90	76	100	100	100
C 2.1	1	E	-	45	65	-	-	-	F	80	68	90	90	90
C 2.2	1	E	-	45	40	-	-	-	F	65	55	60	60	60
C 2.3	2	C	-	45	40	-	-	-	D	50	42	55	55	55
C 2.4	2	B	-	60	50	-	-	-	C	65	55	70	70	70
C 3.1	1	B	-	40	30	-	-	-	C	45	38	50	50	50
C 3.2	2	A	-	30	25	-	-	-	B	35	29	40	40	40
C 3.3	2	A	-	-	-	-	-	-	B	30	25	30	30	30
C 3.4	2	A	-	-	-	-	-	-	A	30	25	30	30	30
C 3.5	2	A	-	-	-	-	-	-	A	25	21	25	25	25
C 4.1	2	C	-	40	35	-	-	-	D	50	42	60	60	60
C 4.2	2	C	-	30	25	-	-	-	D	60	51	70	70	70

Kühlmedium
Coolant

1 = Emulsion
1 = emulsion

2 = Öl
2 = oil

3 = Luft (*3 = nur Luft ohne Zusätze)
3 = air (*3 = only air without additives)

◆ Kühlmedium
Coolant

03



Schnittgeschwindigkeit V_c (m/min)
Cutting speed V_c (m/min)

			171 171F	170-90° 170-90°F 170-120° 170-120°F	181 181F	182 182F	117 117D	217 217D	118 118E	150 150F	162 162F	162L 162LF	163 163F
◆ f (mm)			V_c (m/min) - für Bohrer ohne Beschichtung V_c (m/min) - for drills without coating										
Rost- und säurebeständige Stähle - VA Stähle <i>Stainless steels</i>													
D 1.1	2	D	40	40	40	40	-	-	-	-	-	-	45
D 1.2	2	D	25	25	25	25	-	-	-	-	-	-	30
D 1.3	2	C	25	25	25	25	-	-	-	-	-	-	30
D 1.4	2	B	20	20	20	20	-	-	-	20	25	21	25
D 1.5	2	A	18	18	18	18	-	-	-	18	20	17	20
Nickel/Kobalt Legierungen - Titan - Titan Legierungen <i>Nickel/Cobalt alloys - Titanium - Titanium alloys</i>													
E 1.1	2	D	30	30	30	30	-	-	-	-	-	-	45
E 1.2	2	C	25	25	25	25	-	-	-	-	-	-	40
E 1.3	2	B	25	25	25	25	-	-	-	-	-	-	35
E 2.1	2	B	25	25	25	25	-	-	-	25	35	30	40
E 2.2	1	B	20	20	20	20	-	-	-	20	20	17	35
E 2.3	2	A	18	18	18	18	-	-	-	-	18	15	25
Gußwerkstoffe <i>Cast irons</i>													
F 1.1	1	H	100	100	100	100	-	-	-	100	100	85	140
F 1.2	1	H	85	85	85	85	-	-	-	85	85	72	110
F 1.3	1	B	20	20	20	20	-	-	-	20	20	17	30
F 1.4	1	G	85	85	85	85	-	-	-	85	85	72	90
F 1.5	1	F	80	80	80	80	-	-	-	80	80	68	70
F 2.1	1	G	85	85	85	85	-	-	-	85	85	72	90
F 2.2	1	G	80	80	80	80	-	-	-	70	80	68	70
F 2.3	1	E	90	90	90	90	-	-	-	-	-	-	70
F 2.4	1	E	70	70	70	70	-	-	-	-	-	-	70
Graphit - Wolfram/Kupferlegierungen <i>Graphite - Tungsten/Copper alloys</i>													
G 1.1	3	D	70	70	70	70	-	-	-	-	-	-	80
G 2.1	1	F	75	75	75	75	-	-	-	-	-	-	80
Kunststoffe - Faserverstärkte Kunststoffe - Ne Werkstoffe <i>Plastics - Reinforced plastic fibres - Non ferrous materials</i>													
B 1.1	1	G	80	80	80	80	-	-	180	-	-	-	-
B 1.2	2	E	70	70	70	70	-	-	150	-	-	-	-
B 1.3	1	E	70	70	70	70	-	-	120	-	-	-	-
B 1.4	1	C	40	40	40	40	300	300	150	-	-	-	60
B 1.5	1	D	50	50	50	50	-	-	120	-	-	-	-
B 2.1	-	C	70	70	70	70	-	-	120	-	-	-	-
B 2.2	1	B	-	-	-	-	-	-	120	-	-	-	-
B 2.3	-	E	80	80	80	80	-	-	120	-	-	-	-
B 2.4	-	E	-	-	-	-	-	-	120	-	-	-	-

Kühlmedium 1 = Emulsion 2 = Öl 3 = Luft (*3 = nur Luft ohne Zusätze)
Coolant 1= emulsion 2 = oil 3 = air (*3 = only air without additives)

◆ Kühlmedium
Coolant

Schnittgeschwindigkeit V_c (m/min)
Cutting speed V_c (m/min)

	◆	f (mm)	164	160	161	165	166	172	Code	174	174L	175	176	177
			164F	160F	161F	165F	166F	172F	f (mm)	174F	174LF	175F	176F	177F
V_c (m/min) - für Bohrer ohne Beschichtung V_c (m/min) - for drills without coating														
Rost- und säurebeständige Stähle - VA Stähle <i>Stainless steels</i>														
D 1.1	2	D	35	45	40	30	20	35	E	50	42	55	55	55
D 1.2	2	D	30	30	25	25	20	30	E	40	34	50	50	50
D 1.3	2	C	-	30	25	-	-	-	E	40	34	45	45	45
D 1.4	2	B	-	25	20	20	-	-	D	35	29	40	40	40
D 1.5	2	A	-	20	18	-	-	-	C	30	25	35	35	35
Nickel/Kobalt Legierungen - Titan - Titan Legierungen <i>Nickel/Cobalt alloys - Titanium - Titanium alloys</i>														
E 1.1	2	D	-	35	30	30	25	-	D	35	29	40	40	40
E 1.2	2	C	-	30	25	25	20	-	D	30	25	35	35	35
E 1.3	2	B	-	30	25	25	20	-	C	30	25	35	35	35
E 2.1	2	B	-	35	25	-	-	-	B	40	34	45	45	45
E 2.2	1	B	-	30	20	-	-	-	B	35	29	40	40	40
E 2.3	2	A	-	20	18	-	-	-	B	25	21	25	25	25
Gußwerkstoffe <i>Cast irons</i>														
F 1.1	1	H	-	130	100	150	135	-	K	170	144	180	180	180
F 1.2	1	H	-	100	85	100	80	-	K	120	102	130	130	130
F 1.3	1	B	-	25	20	-	-	-	C	30	25	35	35	35
F 1.4	1	G	100	100	85	100	80	100	K	130	110	120	120	120
F 1.5	1	F	80	90	80	80	70	80	H	100	85	110	110	110
F 2.1	1	G	100	100	85	100	80	100	H	130	110	120	120	120
F 2.2	1	G	90	90	80	80	70	90	H	100	85	110	110	110
F 2.3	1	E	80	70	90	80	70	80	F	90	76	100	100	100
F 2.4	1	E	80	70	70	80	70	80	F	90	76	100	100	100
Graphit - Wolfram/Kupferlegierungen <i>Graphite - Tungsten/Copper alloys</i>														
G 1.1	3	D	-	70	70	70	70	-	-	-	-	-	-	-
G 2.1	1	F	-	90	75	100	80	-	G	90	76	120	120	120
Kunststoffe - Faserverstärkte Kunststoffe - Ne Werkstoffe <i>Plastics - Reinforced plastic fibres - Non ferrous materials</i>														
B 1.1	1	G	-	100	80	80	60	-	-	-	-	-	-	-
B 1.2	2	E	-	80	70	80	60	-	-	-	-	-	-	-
B 1.3	1	E	-	80	70	80	60	-	-	-	-	-	-	-
B 1.4	1	C	-	40	40	-	-	-	D	40	34	-	-	-
B 1.5	1	D	-	60	50	60	50	-	-	-	-	-	-	-
B 2.1	-	C	-	70	70	60	50	-	-	-	-	-	-	-
B 2.2	1	B	-	-	-	60	50	-	-	-	-	-	-	-
B 2.3	-	E	-	80	80	80	80	-	-	-	-	-	-	-
B 2.4	-	E	-	-	-	-	-	-	-	-	-	-	-	-

Kühlmedium
Coolant

1 = Emulsion
1 = emulsion

2 = Öl
2 = oil

3 = Luft (*3 = nur Luft ohne Zusätze)
3 = air (*3 = only air without additives)

◆ Kühlmedium
Coolant

Vorschubempfehlung f (mm) (Richtwerte)
Recommended feed rate f (mm) (Reference values)

D _c (mm)	Vorschub Code / Feed code								
	A	B	C	D	E	F	G	H	K
	f (mm) - Bohrwerkzeuge / f (mm) - drilling tools								
1,00	0,006	0,008	0,012	0,014	0,016	0,018	0,020	0,023	0,025
1,50	0,012	0,015	0,020	0,025	0,030	0,035	0,045	0,050	0,060
2,00	0,020	0,025	0,032	0,040	0,050	0,060	0,080	0,100	0,120
2,50	0,025	0,032	0,040	0,050	0,060	0,080	0,100	0,120	0,160
3,00	0,030	0,035	0,045	0,060	0,080	0,100	0,125	0,160	0,180
4,00	0,040	0,050	0,060	0,080	0,100	0,120	0,160	0,200	0,220
5,00	0,040	0,050	0,060	0,080	0,100	0,120	0,160	0,200	0,250
6,00	0,050	0,060	0,080	0,100	0,120	0,160	0,200	0,250	0,300
7,00	0,050	0,060	0,080	0,100	0,120	0,160	0,200	0,250	0,320
8,00	0,060	0,080	0,100	0,120	0,160	0,200	0,250	0,300	0,350
9,00	0,060	0,080	0,100	0,120	0,160	0,200	0,250	0,300	0,380
10,00	0,080	0,100	0,120	0,160	0,200	0,250	0,300	0,400	0,400
11,00	0,080	0,100	0,120	0,160	0,200	0,250	0,300	0,400	0,450
12,00	0,080	0,100	0,120	0,160	0,200	0,250	0,300	0,400	0,500
13,00	0,080	0,100	0,120	0,160	0,200	0,250	0,300	0,400	0,500
14,00	0,090	0,120	0,140	0,180	0,220	0,280	0,350	0,450	0,550
15,00	0,090	0,120	0,140	0,180	0,220	0,280	0,350	0,450	0,550
16,00	0,100	0,120	0,160	0,200	0,250	0,300	0,400	0,500	0,600
18,00	0,100	0,120	0,160	0,200	0,250	0,300	0,400	0,500	0,600
20,00	0,120	0,160	0,200	0,250	0,300	0,400	0,500	0,600	0,600

03

Schnittgeschwindigkeiten V_c (m/min) - Drehzahlen n (min⁻¹)
Cutting speed V_c (m/min) - Revolution speed n (min⁻¹)

D _c (mm)	V _c (m/min)														
	12	16	20	25	30	40	50	60	80	100	120	160	180	200	250
	Drehzahl n (min ⁻¹) / Revolution speed n (min ⁻¹)														
1,00	3822	5096	6369	7962	9554	12739	15924	19108	25478	31847	38217	50955	57325	63694	79618
1,50	2548	3397	4246	5308	6369	8493	10616	12739	16985	21231	25478	33970	38217	42463	53079
2,00	1911	2548	3185	3981	4777	6369	7962	9554	12739	15924	19108	25478	28662	31847	39809
2,50	1529	2038	2548	3185	3822	5096	6369	7643	10191	12739	15287	20382	22930	25478	31847
3,00	1274	1699	2123	2654	3185	4246	5308	6369	8493	10616	12739	16985	19108	21231	26539
4,00	955	1274	1592	1990	2389	3185	3981	4777	6369	7962	9554	12739	14331	15924	19904
5,00	764	1019	1274	1592	1911	2548	3185	3822	5096	6369	7643	10191	11465	12739	15924
6,00	637	849	1062	1327	1592	2123	2654	3185	4246	5308	6369	8493	9554	10616	13270
7,00	546	728	910	1137	1365	1820	2275	2730	3640	4550	5460	7279	8189	9099	11374
8,00	478	637	796	995	1194	1592	1990	2389	3185	3981	4777	6369	7166	7962	9952
9,00	425	566	708	885	1062	1415	1769	2123	2831	3539	4246	5662	6369	7077	8846
10,00	382	510	637	796	955	1274	1592	1911	2548	3185	3822	5096	5732	6369	7962
11,00	347	463	579	724	869	1158	1448	1737	2316	2895	3474	4632	5211	5790	7238
12,00	318	425	531	663	796	1062	1327	1592	2123	2654	3185	4246	4777	5308	6635
13,00	294	392	490	612	735	980	1225	1470	1960	2450	2940	3920	4410	4900	6124
14,00	273	364	455	569	682	910	1137	1365	1820	2275	2730	3640	4095	4550	5687
15,00	255	340	425	531	637	849	1062	1274	1699	2123	2548	3397	3822	4246	5308
16,00	239	318	398	498	597	796	995	1194	1592	1990	2389	3185	3583	3981	4976
18,00	212	283	354	442	531	708	885	1062	1415	1769	2123	2831	3185	3539	4423
20,00	191	255	318	398	478	637	796	955	1274	1592	1911	2548	2866	3185	3981

Spiralbohrer - Technische Daten und Bezeichnungen

Twist drills - Technical data and descriptions

Schneidenecke Corner edge
Fasenbreite Leading edge width
Nebenschneide Leading
Hauptfreifläche Surface clearance
Hauptschneide Primary cutting edge
Spanfläche Undercut
Stegbreite Clearance

Rücken Dorsal diameter
Querschneide Cross cutting edge
Bohrerdurchmesser Nominal diameter
Rückenkante Dorsal edge
Spannut Chip room
Kerndicke Web thickness

Ψ = Querschnitwinkel / penetration angle
 σ = Spitzenwinkel / point angle

Als Bezugspunkt ist die Schneidfläche gewählt
 The surface cutting edge has been chosen as reference point

Hauptschneide Main cutting edge
Wirkrichtungswinkel Shearing force direction angle
Schnittweg pro Umdrehung Cutting route/r = d
Vorschub pro Umdrehung Feed/r
Wirkrichtung Cutting direction
Schnittweg Infeed direction
Vorschubrichtung Feed direction

α_x Seitenfreiwinkel
 α_{xe} Wirk-Seitenfreiwinkel
 β_x Seitenkeilwinkel
 γ_x Seitenspanwinkel
 γ_{xe} Wirkseitenspanwinkel
 η Wirkrichtungswinkel
 Freiwinkel α ,
 Keilwinkel β
 und Spanwinkel γ
 werden in der Keil
 meße Ebene gemessen

α_x nominal lower rake angle
 α_{xe} effective lower rake angle
 β_x lower cutting edge
 γ_x nominal upper rake angle
 γ_{xe} effective upper rake angle
 η shearing force direction angle
 α, β, γ
 are measured
 in relation to the plane
 delimited by the angle

03

Anschliffbeispiele - Teilweise DIN 1412

Examples of shape points - Partially according to DIN 1412

Form A
Ausgespitzte Querschneide
Thinned chisel edge

Form B
Ausgespitzte Querschneide
korrigierte Hauptschneide
Thinned chisel edge with corrected cutting edge

Form C
Kreuzanschliff
Split point

Form D
Point Boden für Gusseisen
Point ground for cast iron

Selbstzentrierender Anschliff
mit Doppelführung
Self centering point with double guidance

Hochleistungs-Form Punkt für
Bearbeitungszentren
High performance shape of point
for machining centers

PIKTOGRAMME ERKLÄRUNG ICONS DESCRIPTION

Hartmetall Qualität <i>Carbide grade</i>	HM CK10-20-MG Micrograin	Kühlkanäle gedreht <i>Spiral coolant ducts</i>	
Hartmetall Qualität <i>Carbide grade</i>	HM CK20-30-MG Micrograin	Kühlkanäle gerade, zentrisch <i>Straight centric coolant duct</i>	
Werkzeugausführung nach Werksnorm <i>Cutting edge design acc. to internal standard</i>	WN	Kühlkanäle gerade <i>Straight coolant ducts</i>	
Werkzeugbaumaße nach DIN <i>Dimensions acc. to DIN 333-A</i>	DIN 333-A	mit Emulsion - Öl <i>with oil emulsion</i>	
Werkzeugbaumaße nach DIN <i>Dimensions acc. to DIN 338</i>	DIN 338	Trockenbearbeitung <i>Dry machining</i>	
Werkzeugbaumaße nach DIN <i>Dimensions acc. to DIN 6537-K</i>	DIN 6537-K	Bearbeitung mit Druckluft <i>with compressed air</i>	
Werkzeugbaumaße nach DIN <i>Dimensions acc. to DIN 6537-L</i>	DIN 6537-L	Spiralwinkel <i>Helix angle</i>	
Werkzeugbaumaße nach DIN <i>Dimensions acc. to DIN 6539</i>	DIN 6539	Spiralwinkel <i>Helix angle</i>	
Werkzeug - Länge <i>Tool length</i>		Gerade genutet <i>Straight flute</i>	
Werkzeug - Länge <i>Tool length</i>		Spitzenwinkel <i>Point angle</i>	
Werkzeug - Länge <i>Tool length</i>		Spitzenwinkel <i>Point angle</i>	
Schaftausführung DIN 6535 HE <i>Shank acc. to DIN 6535 HE</i>	DIN 6535-HE	Spitzenwinkel <i>Point angle</i>	
Schaftausführung DIN 6535 HEK <i>Shank acc. to DIN 6535 HEK</i>	DIN 6535-HEK	Spitzenwinkel <i>Point angle</i>	

PIKTOGRAMME ERKLÄRUNG
ICONS DESCRIPTION

Spitzenwinkel
Point angle

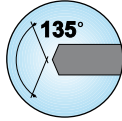

Werkzeugdurchmesser D_c
Tool diameter D_c

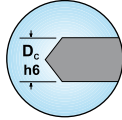

Werkzeugdurchmesser D_c
Tool diameter D_c

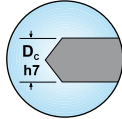

Werkzeugdurchmesser D_c
Tool diameter D_c

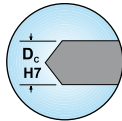

Bearbeitungsbeispiel
Application example

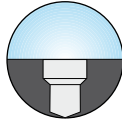

Bearbeitungsbeispiel
Application example

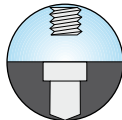

Zentrierbohrer - Form A - 60°
Center drills - Form A - 60°

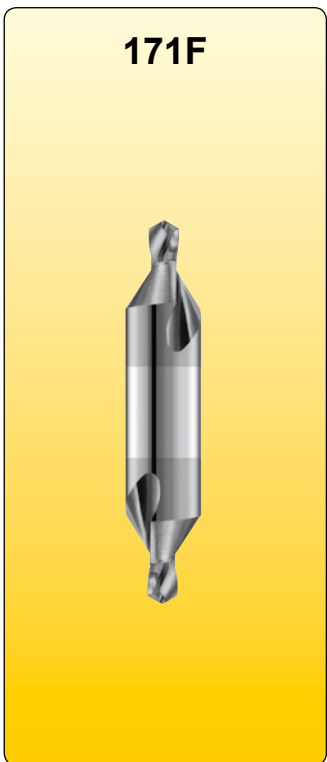
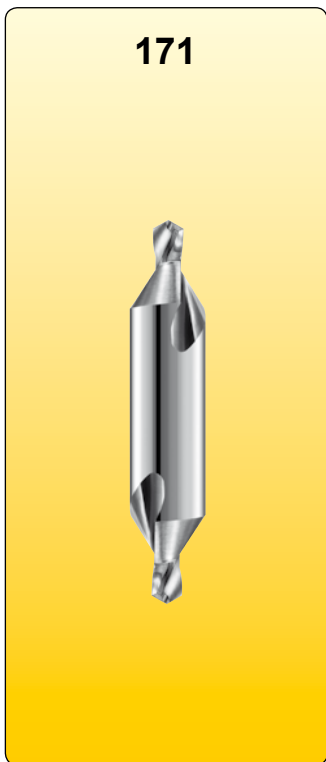

Einsatzgebiete / Range of application

A: Legierungen / Light alloys
 A1.1-1.6 A2.1-2.7 A3.1-3.2 A4.1-4.2

C: Stahlwerkstoffe / Steels
 C1.1-1.8 C2.1-2.4 C3.1 C4.1-4.2

D: Edelstahl / Stainless Steel
 D1.1-1.5

E: Titan / Titanium
 E1.1-1.3 E2.1-2.2

F: Gußeisen / Cast irons
 F1.1-1.5 F2.1-2.4

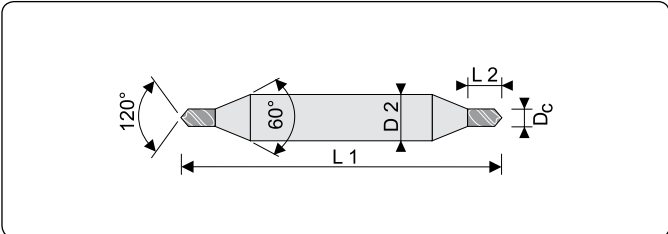

3.01

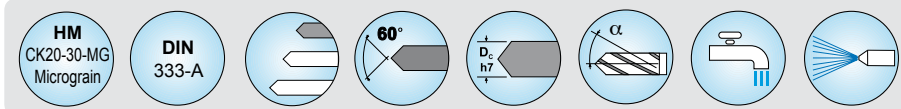

D _c h7	L2	L1	D2 h6	171	171F
					Beschichtet / Coated
2	2,5	40	5	171.020	171.020F
2,5	3,1	45	6,3	171.025	171.025F
3,15	3,9	50	8	171.315	171.315F
4	5	56	10	171.040	171.040F
5	6,3	63	12,5	171.050	171.050F
6,3	8	71	16	171.063	171.063F

Kombi Bohr- Reibwerkzeug-für faserverstärkte Kunststoffe - WN

"DUO-K"

Combi drilling/reaming tool for reinforced plastic fibres - Internal standard

"DUO-K"

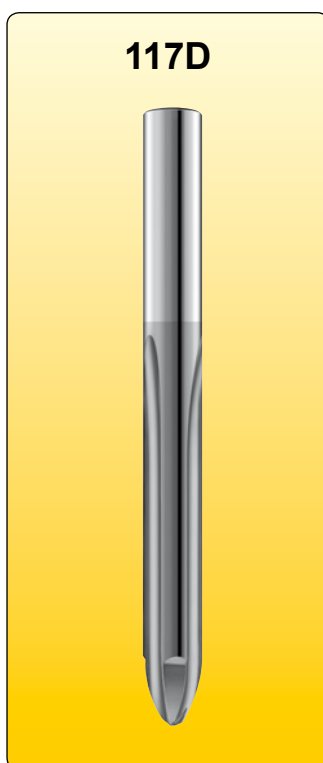
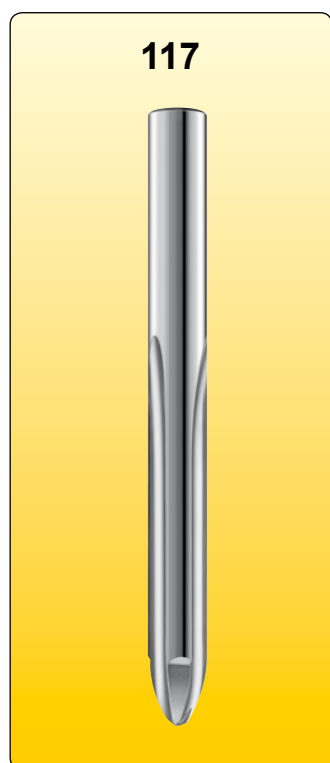

Einsatzgebiete / Range of application

B: Kunststoffe - Faserverstärkte Kunststoffe
 B: Plastics - Reinforced plastic fibres
 B1.4

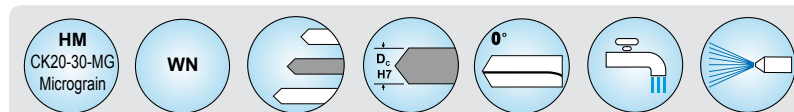
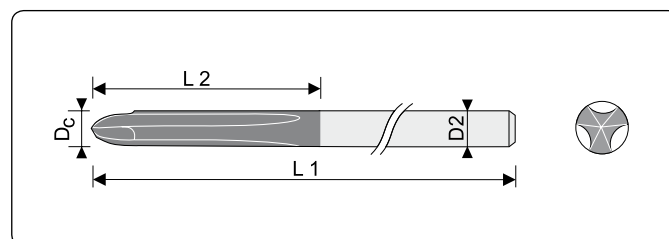

3.03

D _c H7	L2	L1	D2 H7	117	117D
					Beschichtet / Coated
2	50	100	2	117.020	117.020D
2,48	50	100	2,48	117.0248	117.0248D
3	50	100	3	117.030	117.030D
3,17	50	100	3,17	117.0317	117.0317D
4	50	100	4	117.040	117.040D
4,21	50	100	4,21	117.0421	117.0421D
4,82	50	100	4,82	117.0482	117.0482D
5,05	50	100	5,05	117.0505	117.0505D
5,53	50	100	5,53	117.0553	117.0553D
6	50	100	6	117.060	117.060D
6,35	50	100	6,35	117.0635	117.0635D
7	50	100	7	117.070	117.070D
7,92	50	100	7,92	117.0792	117.0792D
8	50	100	8	117.080	117.080D
8,63	50	100	8,63	117.0863	117.0863D
9	50	100	9	117.090	117.090D
10	50	100	10	117.100	117.100D
12	50	100	12	117.120	117.120D

Kombi Bohr- Reibwerkzeug-für faserverstärkte Kunststoffe - WN Z=4

"DUO-K"

Combi drilling/reaming tool for reinforced plastic fibres - Internal standard Z=4

"DUO-K"

Einsatzgebiete / Range of application

B: Kunststoffe - Faserverstärkte Kunststoffe
 B: Plastics - Reinforced plastic fibres
 B1.4

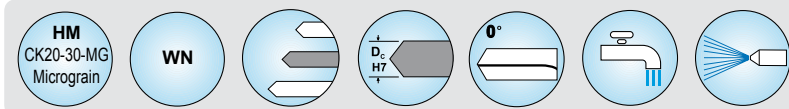
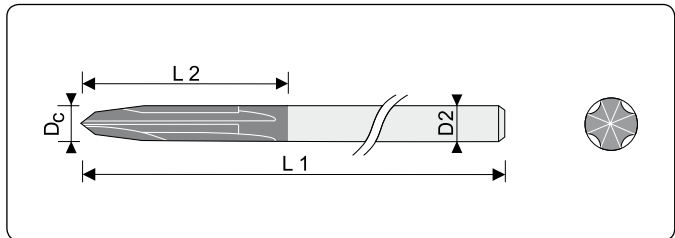

D _c H7	L2	L1	D2 H7	217	217D
					Beschichtet / Coated
2	50	100	2	217.020	217.020D
2,48	50	100	2,48	217.0248	217.0248D
3	50	100	3	217.030	217.030D
3,17	50	100	3,17	217.0317	217.0317D
4	50	100	4	217.040	217.040D
4,21	50	100	4,21	217.0421	217.0421D
4,82	50	100	4,82	217.0482	217.0482D
5,05	50	100	5,05	217.0505	217.0505D
5,53	50	100	5,53	217.0553	217.0553D
6	50	100	6	217.060	217.060D
6,35	50	100	6,35	217.0635	217.0635D
6,60	50	100	6,60	217.660	217.660D
7	50	100	7	217.070	217.070D
7,92	50	100	7,92	217.0792	217.0792D
8	50	100	8	217.080	217.080D
8,63	50	100	8,63	217.0863	217.0863D
9	50	100	9	217.090	217.090D
10	50	100	10	217.100	217.100D
12	50	100	12	217.120	217.120D

3.03

Sternbohrer - gerade genutet - DIN 6539
Star drills straight flute - DIN 6539

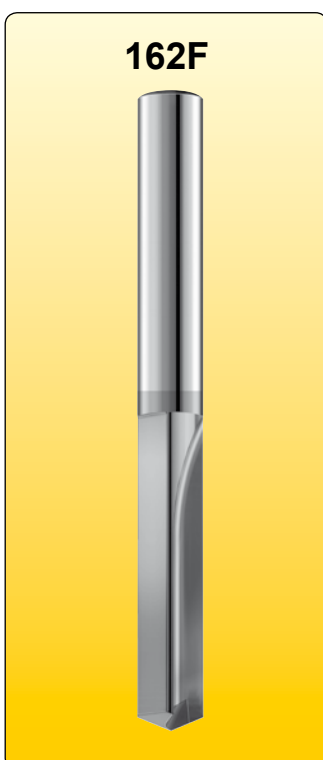
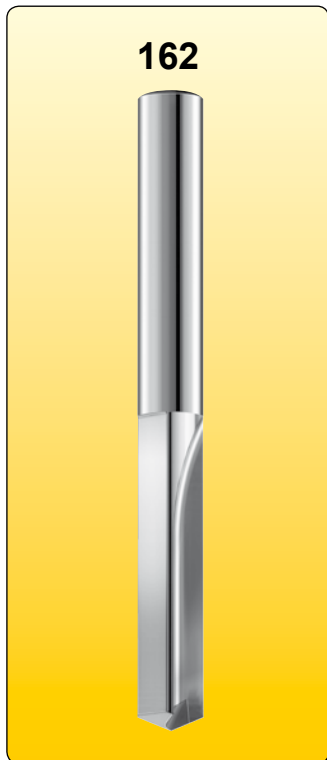

Einsatzgebiete / Range of application

A: Legierungen / Light alloys
A1.3-1.8

F: Gußeisen / Cast irons
F1.1-1.5

E: Titan / Titanium
E1.1-1.3 E2.1-2.3

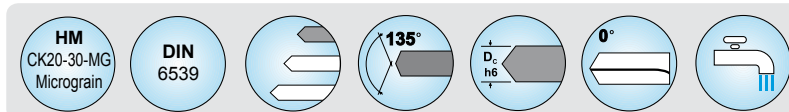
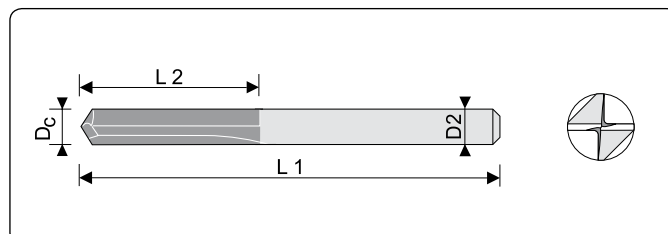

3.
03

D _c h6	L2	L1	D2 h6	162	162F
					Beschichtet / Coated
2	12	38	2	162.020	162.020F
2,5	14	43	2,5	162.025	162.025F
3	16	46	3	162.030	162.030F
3,5	20	52	3,5	162.035	162.035F
4	22	55	4	162.040	162.040F
4,5	24	58	4,5	162.045	162.045F
5	26	62	5	162.050	162.050F
5,5	28	66	5,5	162.055	162.055F
6	28	66	6	162.060	162.060F
6,5	31	70	6,5	162.065	162.065F
8	37	79	8	162.080	162.080F
8,5	37	79	8,5	162.085	162.085F
9	40	84	9	162.090	162.090F
9,5	40	84	9,5	162.095	162.095F
9,8	43	89	9,8	162.098	162.098F
10	43	89	10	162.100	162.100F
10,5	43	89	10,5	162.105	162.105F
11	47	95	11	162.110	162.110F
11,5	47	95	11,5	162.115	162.115F
12	51	102	12	162.120	162.120F
12,5	51	102	12,5	162.125	162.125F
13	51	102	13	162.130	162.130F
13,5	54	107	13,5	162.135	162.135F



Sternbohrer - gerade genutet - kurz DIN 1897
Star drills straight flute - short according to DIN 1897

D _c h6	L2	L1	D2 h6	162	162F
					Beschichtet / Coated
14	54	107	14	162.140	162.140F
14,5	56	111	14,5	162.145	162.145F
15	56	111	15	162.150	162.150F
15,5	58	115	15,5	162.155	162.155F
16	58	115	16	162.160	162.160F

Spiralbohrer - 3 Schneiden - DIN 6539
3 flute twist drills - DIN 6539

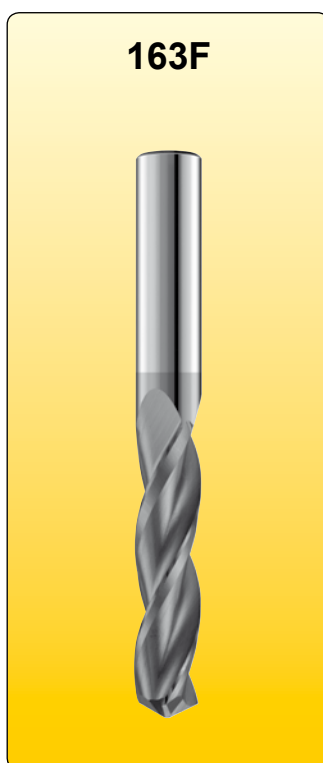

Einsatzgebiete / Range of application

A: Legierungen / Light alloys
 A1.1-1.7 A2.1-2.7 A3.1-3.2 A4.1-4.2

C: Stahlwerkstoffe / Steels
 C1.1-1.8 C2.1-2.4 C3.1-3.5 C4.1-4.2

D: Edelstahl / Stainless Steel
 D1.2 D1.4

E: Titan / Titanium
 E1.1-1.3 E2.1-2.3

F: Gußeisen / Cast irons
 F1.1-1.5 F2.1-2.4

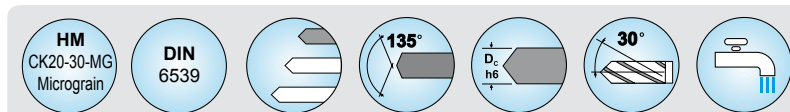
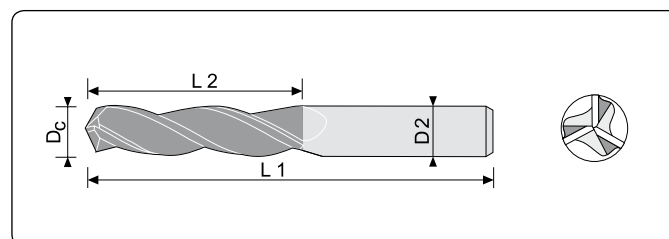

**3.
03**

D _c h6	L2	L1	D2 h6	163	163F
					Beschichtet / Coated
3	16	46	3	163.030	163.030F
3,5	20	52	3,5	163.035	163.035F
4	22	55	4	163.040	163.040F
4,5	24	58	4,5	163.045	163.045F
5	26	62	5	163.050	163.050F
5,5	28	66	5,5	163.055	163.055F
6	28	66	6	163.060	163.060F
6,5	31	70	6,5	163.065	163.065F
7	34	74	7	163.070	163.070F
7,5	34	74	7,5	163.075	163.075F
8	37	79	8	163.080	163.080F
8,5	37	79	8,5	163.085	163.085F
9	40	84	9	163.090	163.090F
9,5	40	84	9,5	163.095	163.095F
10	43	89	10	163.100	163.100F
10,5	43	89	10,5	163.105	163.105F
11	47	95	11	163.110	163.110F
11,5	47	95	11,5	163.115	163.115F
12	51	102	12	163.120	163.120F
12,5	51	102	12,5	163.125	163.125F
13	51	102	13	163.130	163.130F
13,5	54	107	13,5	163.135	163.135F

D _c h6	L2	L1	D2 h6	163	163F
					Beschichtet / Coated
14	54	107	14	163.140	163.140F
14,5	56	111	14,5	163.145	163.145F
15	56	111	15	163.150	163.150F
15,5	58	115	15,5	163.155	163.155F
16	58	115	16	163.160	163.160F
16,5	60	119	16,5	163.165	163.165F
17	60	119	17	163.170	163.170F
17,5	62	123	17,5	163.175	163.175F
18	62	123	18	163.180	163.180F
18,5	64	127	18,5	163.185	163.185F
19	64	127	19	163.190	163.190F
19,5	66	131	19,5	163.195	163.195F
20	66	131	20	163.200	163.200F



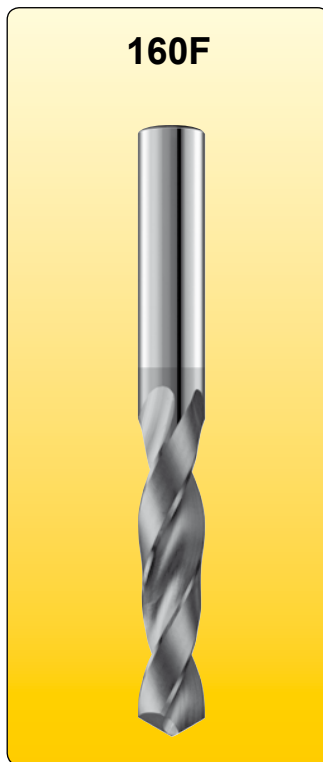
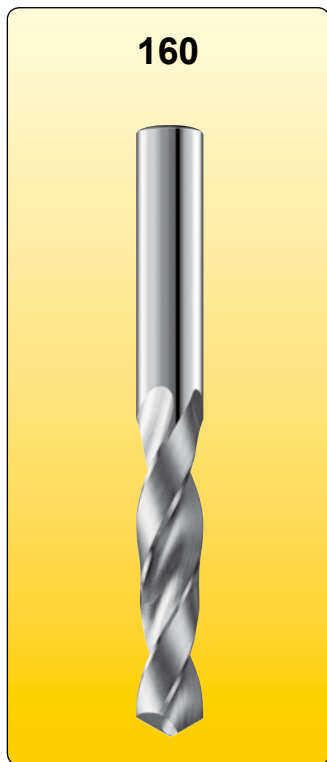



Spiralbohrer - Standardgeometrie - DIN 6539
2 flute twist drills - DIN 6539

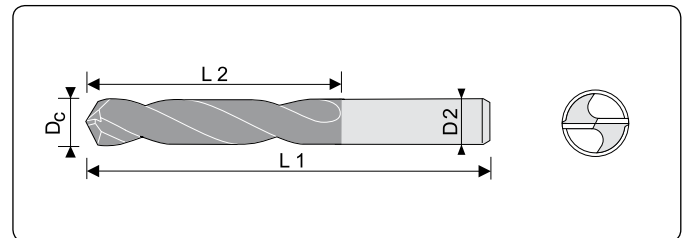

Einsatzgebiete / Range of application

- A: Legierungen / Light alloys**
A1.1-1.7 A2.1-2.7 A3.1-3.2 A4.1-4.2
- B: Kunststoffe - Faserverstärkte Kunststoffe**
B: *Plastics - Reinforced plastic fibres*
B1.1-1.5 B2.1-2.4
- C: Stahlwerkstoffe / Steels**
C1.1-1.8 C2.1-2.3 C3.1-3.2 C4.1-4.2
- F: Gußeisen / Cast irons**
F1.1-1.2 F1.4-1.5 F2.1-2.2
- G: Graphit / Graphite**
G2.1



**3.
03**

D _c h6	L2	L1	D2 h6	160	160F
					Beschichtet / Coated
2	12	38	2	160.020	160.020F
2,1	12	38	2,1	160.021	160.021F
2,2	13	40	2,2	160.022	160.022F
2,3	13	40	2,3	160.023	160.023F
2,4	14	43	2,4	160.024	160.024F
2,5	14	43	2,5	160.025	160.025F
2,6	14	43	2,6	160.026	160.026F
2,7	16	46	2,7	160.027	160.027F
2,8	16	46	2,8	160.028	160.028F
2,9	16	46	2,9	160.029	160.029F
3	16	46	3	160.030	160.030F
3,1	18	49	3,1	160.031	160.031F
3,2	18	49	3,2	160.032	160.032F
3,3	18	49	3,3	160.033	160.033F
3,4	20	52	3,4	160.034	160.034F
3,5	20	52	3,5	160.035	160.035F
3,6	20	52	3,6	160.036	160.036F
3,7	20	52	3,7	160.037	160.037F
3,8	22	55	3,8	160.038	160.038F
3,9	22	55	3,9	160.039	160.039F
4	22	55	4	160.040	160.040F
4,1	22	55	4,1	160.041	160.041F
4,2	22	55	4,2	160.042	160.042F
4,3	24	58	4,3	160.043	160.043F
4,4	24	58	4,4	160.044	160.044F

D _c h6	L2	L1	D2 h6	160	160F
					Beschichtet / Coated
4,5	24	58	4,5	160.045	160.045F
4,6	24	58	4,6	160.046	160.046F
4,7	24	58	4,7	160.047	160.047F
4,8	26	62	4,8	160.048	160.048F
4,9	26	62	4,9	160.049	160.049F
5	26	62	5	160.050	160.050F
5,1	26	62	5,1	160.051	160.051F
5,2	26	62	5,2	160.052	160.052F
5,3	26	62	5,3	160.053	160.053F
5,4	28	66	5,4	160.054	160.054F
5,5	28	66	5,5	160.055	160.055F
5,6	28	66	5,6	160.056	160.056F
5,7	28	66	5,7	160.057	160.057F
5,8	28	66	5,8	160.058	160.058F
5,9	28	66	5,9	160.059	160.059F
6	28	66	6	160.060	160.060F
6,1	31	70	6,1	160.061	160.061F
6,2	31	70	6,2	160.062	160.062F
6,3	31	70	6,3	160.063	160.063F
6,4	31	70	6,4	160.064	160.064F
6,5	31	70	6,5	160.065	160.065F
6,8	34	74	6,8	160.068	160.068F
7	34	74	7	160.070	160.070F
7,5	34	74	7,5	160.075	160.075F
7,8	37	79	7,8	160.078	160.078F
8	37	79	8	160.080	160.080F
8,5	37	79	8,5	160.085	160.085F
9	40	84	9	160.090	160.090F
9,5	40	84	9,5	160.095	160.095F
9,8	43	89	9,8	160.098	160.098F
10	43	89	10	160.100	160.100F
10,2	43	89	10,2	160.102	160.102F
10,5	43	89	10,5	160.105	160.105F
10,8	47	95	10,8	160.108	160.108F
11	47	95	11	160.110	160.110F
11,2	47	95	11,2	160.112	160.112F
11,5	47	95	11,5	160.115	160.115F
11,8	47	95	11,8	160.118	160.118F
12	51	102	12	160.120	160.120F
12,5	51	102	12,5	160.125	160.125F
13	51	102	13	160.130	160.130F
13,5	54	107	13,5	160.135	160.135F
14	54	107	14	160.140	160.140F
14,5	56	111	14,5	160.145	160.145F
15	56	111	15	160.150	160.150F
15,5	58	115	15,5	160.155	160.155F
16	58	115	16	160.160	160.160F
16,5	60	119	16,5	160.165	160.165F
17	60	119	17	160.170	160.170F
17,5	62	123	17,5	160.175	160.175F
18	62	123	18	160.180	160.180F
18,5	64	127	18,5	160.185	160.185F
19	64	127	19	160.190	160.190F
19,5	66	131	19,5	160.195	160.195F
20	66	131	20	160.200	160.200F

Spiralbohrer - Standardgeometrie - lang DIN 338
2 flute twist drills - long according to DIN 338



Einsatzgebiete / Range of application

- A: Legierungen / *Light alloys*
A1.1-1.7 A2.1-2.7 A3.1-3.2 A4.1-4.2
- B: Kunststoffe - Faserverstärkte Kunststoffe
B: *Plastics - Reinforced plastic fibres*
B1.1-1.5 B2.1-2.4
- C: Stahlwerkstoffe / *Steels*
C1.1-1.8 C2.1-2.3 C3.1-3.2 C4.1-4.2
- F: Gußeisen / *Cast irons*
F1.1-1.2 F1.4-1.5 F2.1-2.2
- G: Graphit / *Graphite*
G2.1

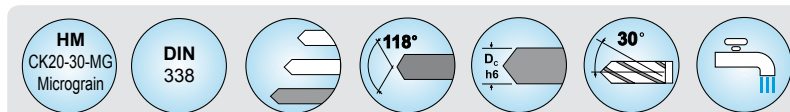
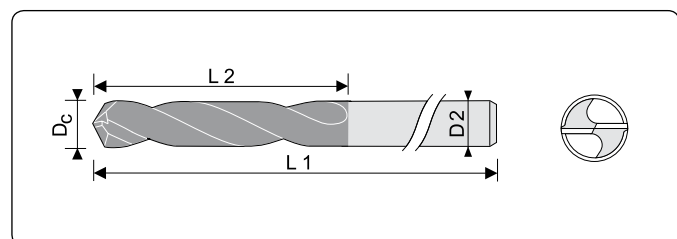

3.
03

D _c h6	L2	L1	D2 h6	161	161F
					Beschichtet / <i>Coated</i>
2	24	49	2	161.020	161.020F
2,1	24	49	2,1	161.021	161.021F
2,2	27	53	2,2	161.022	161.022F
2,3	27	53	2,3	161.023	161.023F
2,4	30	57	2,4	161.024	161.024F
2,5	30	57	2,5	161.025	161.025F
2,6	30	57	2,6	161.026	161.026F
2,7	33	61	2,7	161.027	161.027F
2,8	33	61	2,8	161.028	161.028F
2,9	33	61	2,9	161.029	161.029F
3	33	61	3	161.030	161.030F
3,1	36	65	3,1	161.031	161.031F
3,2	36	65	3,2	161.032	161.032F
3,3	36	65	3,3	161.033	161.033F
3,4	39	70	3,4	161.034	161.034F
3,5	39	70	3,5	161.035	161.035F
3,6	39	70	3,6	161.036	161.036F
3,7	39	70	3,7	161.037	161.037F
3,8	43	75	3,8	161.038	161.038F
3,9	43	75	3,9	161.039	161.039F
4	43	75	4	161.040	161.040F
4,1	43	75	4,1	161.041	161.041F

D _c h6	L2	L1	D2 h6	161	161F
					Beschichtet / Coated
4,2	43	75	4,2	161.042	161.042F
4,3	47	80	4,3	161.043	161.043F
4,4	47	80	4,4	161.044	161.044F
4,5	47	80	4,5	161.045	161.045F
4,6	47	80	4,6	161.046	161.046F
4,7	47	80	4,7	161.047	161.047F
4,8	52	86	4,8	161.048	161.048F
4,9	52	86	4,9	161.049	161.049F
5	52	86	5	161.050	161.050F
5,1	52	86	5,1	161.051	161.051F
5,2	52	86	5,2	161.052	161.052F
5,3	52	86	5,3	161.053	161.053F
5,4	57	93	5,4	161.054	161.054F
5,5	57	93	5,5	161.055	161.055F
5,6	57	93	5,6	161.056	161.056F
5,7	57	93	5,7	161.057	161.057F
5,8	57	93	5,8	161.058	161.058F
5,9	57	93	5,9	161.059	161.059F
6	57	93	6	161.060	161.060F
6,1	63	101	6,1	161.061	161.061F
6,2	63	101	6,2	161.062	161.062F
6,3	63	101	6,3	161.063	161.063F
6,4	63	101	6,4	161.064	161.064F
6,5	63	101	6,5	161.065	161.065F
6,8	69	109	6,8	161.068	161.068F
7	69	109	7	161.070	161.070F
7,5	69	109	7,5	161.075	161.075F
8	75	117	8	161.080	161.080F
8,5	75	117	8,5	161.085	161.085F
9	81	125	9	161.090	161.090F
9,5	81	125	9,5	161.095	161.095F
10	87	133	10	161.100	161.100F
10,5	87	133	10,5	161.105	161.105F
11	94	142	11	161.110	161.110F
11,5	94	142	11,5	161.115	161.115F
12	101	151	12	161.120	161.120F
12,5	101	151	12,5	161.125	161.125F
13	101	151	13	161.130	161.130F
13,5	108	160	13,5	161.135	161.135F
14	108	160	14	161.140	161.140F
14,5	114	169	14,5	161.145	161.145F
15	114	169	15	161.150	161.150F
15,5	120	178	15,5	161.155	161.155F
16	120	178	16	161.160	161.160F

Spiralbohrer - für Guss und Leichtmetall - DIN 6539
Twist drills for cast iron and light alloys - DIN 6539

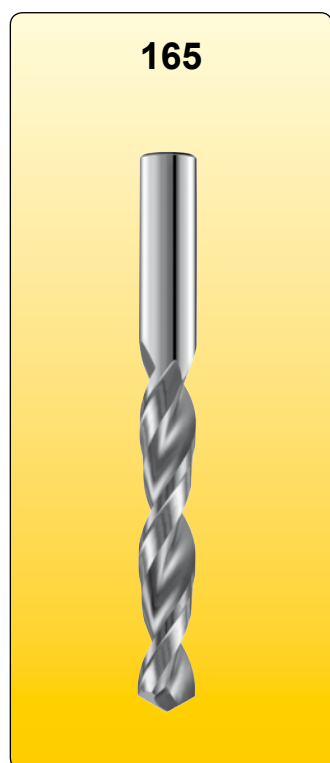

Einsatzgebiete / Range of application

A: Legierungen / Light alloys
 A1.1-1.7 A2.1-2.7 A3.1-3.2 A4.1-4.2

B: Kunststoffe - Faserverstärkte Kunststoffe
 B: Plastics - Reinforced plastic fibres
 B1.1-1.3 B1.5 B2.1-2.3

C: Stahlwerkstoffe / Steels
 C1.1-1.5

E: Titan / Titanium
 E1.1-1.2 E2.1-2.2

F: Gußeisen / Cast irons
 F1.1-1.5 F2.1-2.4

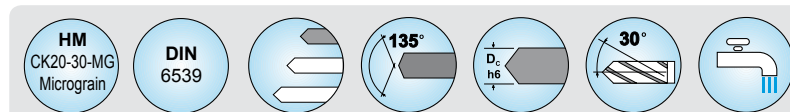
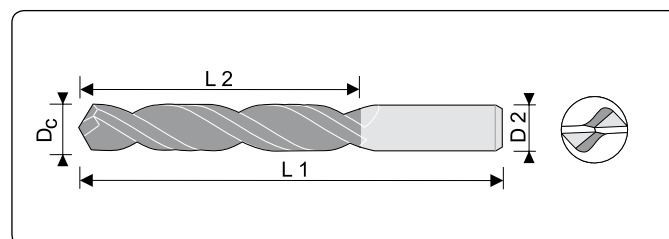

**3.
03**

D _c h6	L2	L1	D2 h6	165	165F
					Beschichtet / Coated
2	12	38	2	165.020	165.020F
2,5	14	43	2,5	165.025	165.025F
3	16	46	3	165.030	165.030F
3,5	20	52	3,5	165.035	165.035F
4	22	55	4	165.040	165.040F
4,5	24	58	4,5	165.045	165.045F
5	26	62	5	165.050	165.050F
5,5	28	66	5,5	165.055	165.055F
6	28	66	6	165.060	165.060F
6,5	31	70	6,5	165.065	165.065F
7	34	74	7	165.070	165.070F
7,5	34	74	7,5	165.075	165.075F
8	37	79	8	165.080	165.080F
8,5	37	79	8,5	165.085	165.085F
9	40	84	9	165.090	165.090F
9,5	40	84	9,5	165.095	165.095F
10	43	89	10	165.100	165.100F
10,5	43	89	10,5	165.105	165.105F
11	47	95	11	165.110	165.110F
12	51	102	12	165.120	165.120F
12,5	51	102	12,5	165.125	165.125F
13	51	102	13	165.130	165.130F
13,5	54	107	13,5	165.135	165.135F
14	54	107	14	165.140	165.140F
14,5	56	111	14,5	165.145	165.145F

D _c h6	L2	L1	D2 h6	165	165F
					Beschichtet / Coated
15	56	111	15	165.150	165.150F
15,5	58	115	15,5	165.155	165.155F
16	58	115	16	165.160	165.160F
16,5	60	119	16,5	165.165	165.165F
17	60	119	17	165.170	165.170F
17,5	62	123	17,5	165.175	165.175F
18	62	123	18	165.180	165.180F
18,5	64	127	18,5	165.185	165.185F
19	64	127	19	165.190	165.190F
19,5	66	131	19,5	165.195	165.195F
20	66	131	20	165.200	165.200F

Spiralbohrer - für Guss und Leichtmetall - lang DIN 338
Twist drills for cast iron and light alloys - long according to DIN 338

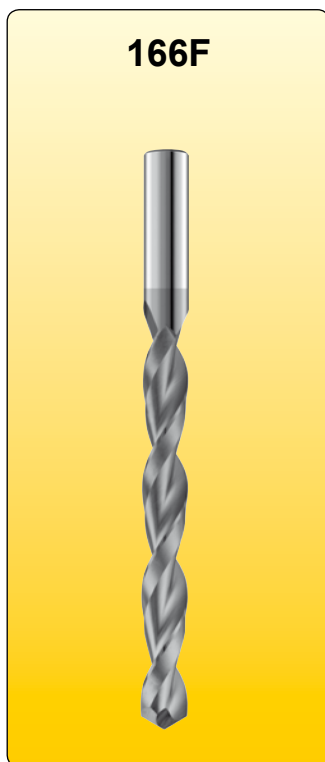
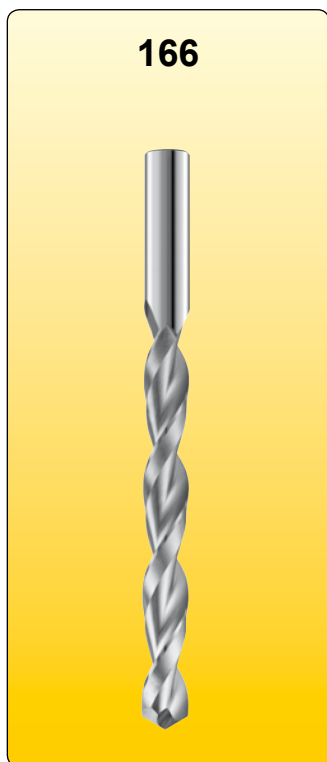

Einsatzgebiete / Range of application

- A: Legierungen / Light alloys
A1.1-1.7 A2.1-2.7 A3.1-3.2 A4.1-4.2
- B: Kunststoffe - Faserverstärkte Kunststoffe
B: Plastics - Reinforced plastic fibres
B1.1-1.3 B1.5 B2.1-2.3
- C: Stahlwerkstoffe / Steels
C1.1-1.5
- E: Titan / Titanium
E1.1-1.2 E2.1-2.2
- F: Gußeisen / Cast irons
F1.1-1.5 F2.1-2.4

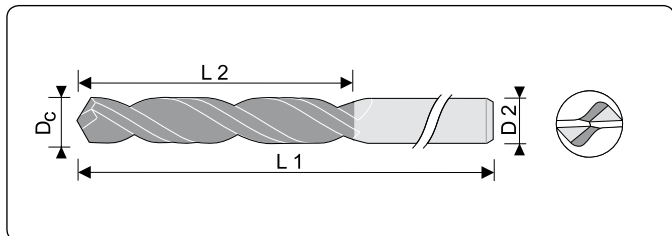



HM
CK20-30-MG
Micrograin

DIN
338













3.
03

D _c h6	L2	L1	D2 h6	166	
				166	166F Beschichtet / Coated
2	24	49	2	166.020	166.020F
2,5	30	57	2,5	166.025	166.025F
3	33	61	3	166.030	166.030F
3,5	39	70	3,5	166.035	166.035F
4	43	75	4	166.040	166.040F
4,5	47	80	4,5	166.045	166.045F
5	52	86	5	166.050	166.050F
5,5	57	93	5,5	166.055	166.055F
6	57	93	6	166.060	166.060F
6,5	63	101	6,5	166.065	166.065F
7	69	109	7	166.070	166.070F
7,5	69	109	7,5	166.075	166.075F
8	75	117	8	166.080	166.080F
8,5	75	117	8,5	166.085	166.085F
9	81	125	9	166.090	166.090F
9,5	81	125	9,5	166.095	166.095F
10	87	133	10	166.100	166.100F
10,5	87	133	10,5	166.105	166.105F
11	94	142	11	166.110	166.110F
11,5	94	142	11,5	166.115	166.115F
12	101	151	12	166.120	166.120F
13	101	151	13	166.130	166.130F

D _c h6	L2	L1	D2 h6	166	166F
					Beschichtet / Coated
14	108	155	14	166.140	166.140F
14,5	114	169	14,5	166.145	166.145F
15	114	169	15	166.150	166.150F
15,5	120	178	15,5	166.155	166.155F
16	120	178	16	166.160	166.160F

Hochleistungs-Spiralbohrer - selbstzentrierend - DIN 6539
High performance twist drills-self centering - DIN 6539

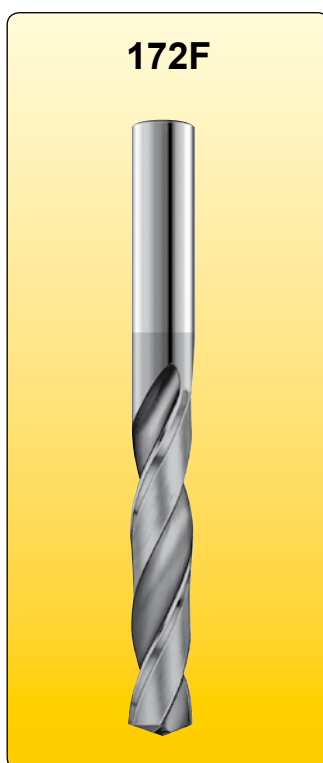
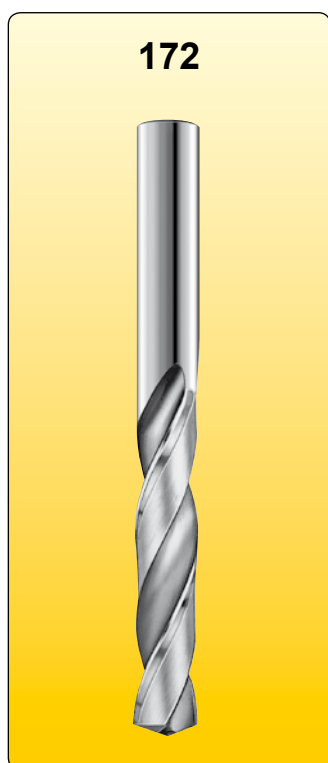

Einsatzgebiete / Range of application

A: Legierungen / Light alloys
 A1.1-1.7 A2.1-2.7 A3.1-3.2 A4.1-4.2

C: Stahlwerkstoffe / Steels
 C1.1-1.8 C2.1-2.4 C3.1-3.5 C4.4-4.2

D: Edelstahl / Stainless Steel
 D1.1-1.5.2

E: Titan / Titanium
 E1.1-1.3 E2.1-2.2

F: Gußeisen / Cast irons
 F1.1-1.5 F2.1-2.4

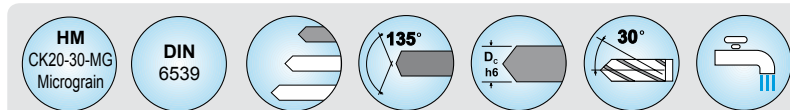
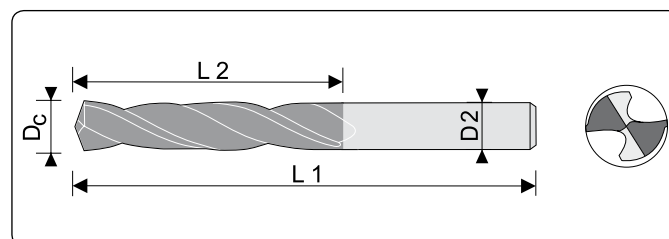

**3.
03**

D _c h6	L2	L1	D2 h6	172	172F
					Beschichtet / Coated
3	16	46	3	172.030	172.030F
3,1	18	49	3,1	172.031	172.031F
3,2	18	49	3,2	172.032	172.032F
3,3	18	49	3,3	172.033	172.033F
3,4	20	52	3,4	172.034	172.034F
3,5	20	52	3,5	172.035	172.035F
3,6	20	52	3,6	172.036	172.036F
3,7	20	52	3,7	172.037	172.037F
3,8	22	55	3,8	172.038	172.038F
3,9	22	55	3,9	172.039	172.039F
4	22	55	4	172.040	172.040F
4,1	22	55	4,1	172.041	172.041F
4,2	22	55	4,2	172.042	172.042F
4,3	24	58	4,3	172.043	172.043F
4,4	24	58	4,4	172.044	172.044F
4,5	24	58	4,5	172.045	172.045F
4,6	24	58	4,6	172.046	172.046F
4,7	24	58	4,7	172.047	172.047F
4,8	26	62	4,8	172.048	172.048F
5	26	62	5	172.050	172.050F
5,1	26	62	5,1	172.051	172.051F
5,3	26	62	5,3	172.053	172.053F

D _c h6	L2	L1	D2 h6	172	172F
					Beschichtet / Coated
5,5	28	66	5,5	172.055	172.055F
5,8	28	66	5,8	172.058	172.058F
6	28	66	6	172.060	172.060F
6,4	31	70	6,4	172.064	172.064F
6,5	31	70	6,5	172.065	172.065F
6,6	31	70	6,6	172.066	172.066F
6,8	34	74	6,8	172.068	172.068F
7	34	74	7	172.070	172.070F
7,5	34	74	7,5	172.075	172.075F
7,8	37	79	7,8	172.078	172.078F
8	37	79	8	172.080	172.080F
8,4	37	79	8,4	172.084	172.084F
8,5	37	79	8,5	172.085	172.085F
8,8	40	84	8,8	172.088	172.088F
9	40	84	9	172.090	172.090F
9,5	40	84	9,5	172.095	172.095F
9,8	43	89	9,8	172.098	172.098F
10	43	89	10	172.100	172.100F
10,2	43	89	10,2	172.102	172.102F
10,5	43	89	10,5	172.105	172.105F
10,8	47	95	10,8	172.108	172.108F
11	47	95	11	172.110	172.110F
11,5	47	95	11,5	172.115	172.115F
11,8	47	95	11,8	172.118	172.118F
12	51	102	12	172.120	172.120F
12,5	51	102	12,5	172.125	172.125F
12,8	51	102	12,8	172.128	172.128F
13	51	102	13	172.130	172.130F
13,5	54	107	13,5	172.135	172.135F
13,8	54	107	13,8	172.138	172.138F
14	54	107	14	172.140	172.140F
14,5	56	111	14,5	172.145	172.145F
14,8	56	111	14,8	172.148	172.148F
15	56	111	15	172.150	172.150F
15,5	58	115	15,5	172.155	172.155F
15,8	58	115	15,8	172.158	172.158F
16	58	115	16	172.160	172.160F
16,5	60	119	16,5	172.165	172.165F
17	60	119	17	172.170	172.170F
17,5	62	123	17,5	172.175	172.175F
18	62	123	18	172.180	172.180F
18,5	64	127	18,5	172.185	172.185F
19	64	127	19	172.190	172.190F
19,5	66	131	19,5	172.195	172.195F
20	66	131	20	172.200	172.200F

Hochleistungs-Spiralbohrer - selbstzentrierend - WN

High performance twist drills-self centering - WN

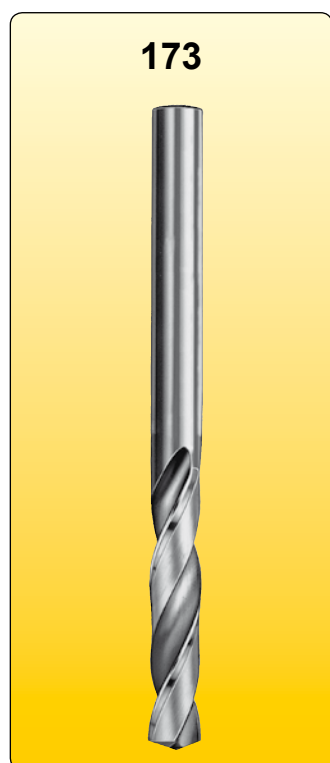

Einsatzgebiete / Range of application

A: Legierungen / Light alloys
A1.1-1.7 A2.1-2.7 A3.1-3.2

C: Stahlwerkstoffe / Steels
C1.1-1.8 C2.1-2.4 C3.1-3.5 C4.4-4.2

D: Edelstahl / Stainless Steel
D1.1-1.5.2

E: Titan / Titanium
E1.1-1.3 E2.1-2.2

F: Gußeisen / Cast irons
F1.1-1.5 F2.1-2.4

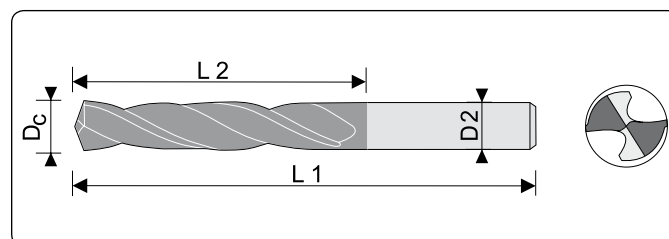

3.
03

D _c h6	L2	L1	D2 h6	173	173F
					Beschichtet / Coated
4	40	75		173.040	173.040F
4,2	40	75		173.042	173.042F
4,3	42	80		173.043	173.043F
4,5	42	80		173.045	173.045F
4,8	45	86		173.048	173.048F
5	45	86		173.050	173.050F
5,1	45	86		173.051	173.051F
5,2	45	86		173.052	173.052F
5,5	48	93		173.055	173.055F
5,8	48	93		173.058	173.058F
6	48	93		173.060	173.060F
6,1	52	101		173.061	173.061F
6,5	52	101		173.065	173.065F
6,6	52	101		173.066	173.066F
6,8	55	109		173.068	173.068F
6,9	55	109		173.069	173.069F
7	55	109		173.070	173.070F
7,5	55	109		173.075	173.075F
7,8	59	117		173.078	173.078F
7,9	59	117		173.079	173.079F
8	59	117		173.080	173.080F
8,5	59	117		173.085	173.085F

D _c h6	L2	L1	D2 h6	173	173F
					Beschichtet / Coated
8,6	65	125		173.086	173.086F
8,8	65	125		173.088	173.088F
9	65	125		173.090	173.090F
9,5	65	125		173.095	173.095F
9,6	69	133		173.096	173.096F
9,8	69	133		173.098	173.098F
10	69	133		173.100	173.100F
10,2	69	133		173.102	173.102F
10,4	69	133		173.104	173.104F
10,5	69	133		173.105	173.105F
10,8	75	142		173.108	173.108F
11	75	142		173.110	173.110F
11,5	75	142		173.115	173.115F
11,8	86	151		173.118	173.118F
12	86	151		173.120	173.120F
12,5	86	151		173.125	173.125F
13	86	151		173.130	173.130F
13,5	92	160		173.135	173.135F
14	92	160		173.140	173.140F
14,2	98	169		173.142	173.142F
14,5	98	169		173.145	173.145F
15	98	169		173.150	173.150F
15,5	105	178		173.155	173.155F
16	105	178		173.160	173.160F
16,5	110	184		173.165	173.165F
17	110	184		173.170	173.170F
17,5	112	191		173.175	173.175F
17,7	112	191		173.177	173.177F
18	112	191		173.180	173.180F
18,5	112	198		173.185	173.185F
19	112	198		173.190	173.190F
19,5	120	205		173.195	173.195F
20	120	205		173.200	173.200F

Hochleistungs-Spiralbohrer-mit Kühlkanälen-selbstzentrierend-kurz DIN 6537-K
High performance twist drills with coolant ducts-self centering-short acc. to DIN 6537-K

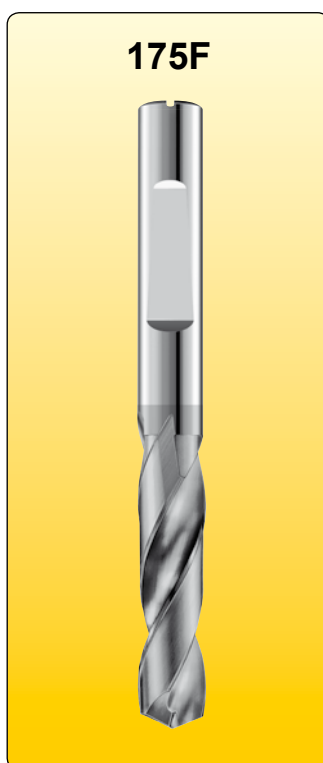
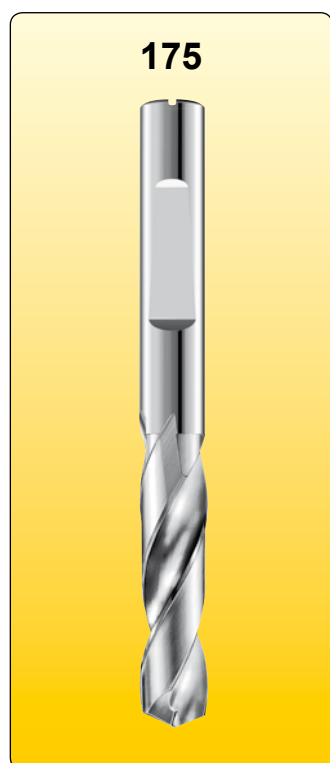

Einsatzgebiete / Range of application

A: Legierungen / Light alloys
 A1.1-1.7 A2.1-2.7 A3.1-3.2

C: Stahlwerkstoffe / Steels
 C1.1-1.8 C2.1-2.4 C3.1-3.5 C4.4-4.2

D: Edelstahl / Stainless Steel
 D1.1-1.5.2

E: Titan / Titanium
 E1.1-1.3 E2.1-2.2

F: Gußeisen / Cast irons
 F1.1-1.5 F2.1-2.4

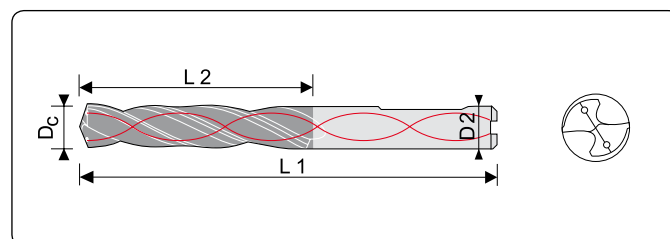

**3.
03**

D _c h6	L2	L1	D2 h6	175	175F
					Beschichtet / Coated
5,8	28	66	6	175.058	175.058F
6	28	66	6	175.060	175.060F
6,8	34	79	8	175.068	175.068F
7	34	79	8	175.070	175.070F
7,8	37	79	8	175.078	175.078F
8	37	79	8	175.080	175.080F
8,5	37	89	10	175.085	175.085F
8,8	40	89	10	175.088	175.088F
9	40	89	10	175.090	175.090F
9,5	40	89	10	175.095	175.095F
9,8	43	89	10	175.098	175.098F
10	43	89	10	175.100	175.100F
10,5	43	102	12	175.105	175.105F
10,8	47	102	12	175.108	175.108F
11	47	102	12	175.110	175.110F
11,5	47	102	12	175.115	175.115F
11,8	47	102	12	175.118	175.118F
12	51	102	12	175.120	175.120F
12,5	51	107	14	175.125	175.125F
13	51	107	14	175.130	175.130F
13,5	51	107	14	175.135	175.135F
14	51	107	14	175.140	175.140F

D _c h6	L2	L1	D2 h6	175	175F
					Beschichtet / Coated
14,5	56	115	16	175.145	175.145F
15	56	115	16	175.150	175.150F
15,5	58	115	16	175.155	175.155F
16	58	115	16	175.160	175.160F
16,5	60	123	18	175.165	175.165F
17	60	123	18	175.170	175.170F
17,5	62	123	18	175.175	175.175F
18	62	123	18	175.180	175.180F
18,5	64	131	20	175.185	175.185F
19	64	131	20	175.190	175.190F
19,5	66	131	20	175.195	175.195F
20	66	131	20	175.200	175.200F

Hochleistungs-Spiralbohrer - mit Kühlkanälen - selbstzentrierend - lang DIN 6537-L
High performance twist drills with coolant ducts-self centering-long acc. to DIN 6537-L



Einsatzgebiete / Range of application

A: Legierungen / Light alloys
 A1.1-1.7 A2.1-2.7 A3.1-3.2

C: Stahlwerkstoffe / Steels
 C1.1-1.8 C2.1-2.4 C3.1-3.5 C4.4-4.2

D: Edelstahl / Stainless Steel
 D1.1-1.5.2

E: Titan / Titanium
 E1.1-1.3 E2.1-2.2

F: Gußeisen / Cast irons
 F1.1-1.5 F2.1-2.4

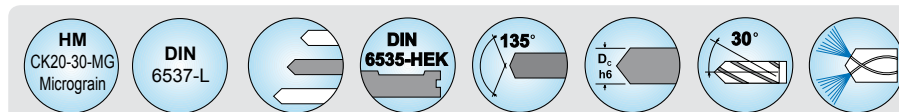
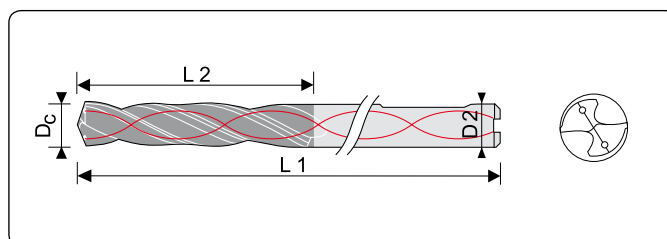

**3.
03**

D _c h6	L2	L1	D2 h6	176	176F
					Beschichtet / Coated
5,8	40	82	6	176.058	176.058F
6	40	82	6	176.060	176.060F
6,8	45	91	8	176.068	176.068F
7	45	91	8	176.070	176.070F
7,8	48	91	8	176.078	176.078F
8	48	91	8	176.080	176.080F
8,5	52	103	10	176.085	176.085F
8,8	54	103	10	176.088	176.088F
9	54	103	10	176.090	176.090F
9,5	56	103	10	176.095	176.095F
9,8	58	103	10	176.098	176.098F
10	58	103	10	176.100	176.100F
10,5	65	118	12	176.105	176.105F
10,8	66	118	12	176.108	176.108F
11	66	118	12	176.110	176.110F
11,5	70	118	12	176.115	176.115F
11,8	70	118	12	176.118	176.118F
12	72	118	12	176.120	176.120F
12,5	72	124	14	176.125	176.125F
13	76	124	14	176.130	176.130F
13,5	76	124	14	176.135	176.135F
14	76	124	14	176.140	176.140F

D _c h6	L2	L1	D2 h6	176	176F
					Beschichtet / Coated
14,5	78	133	16	176.145	176.145F
15	80	133	16	176.150	176.150F
15,5	80	133	16	176.155	176.155F
16	80	133	16	176.160	176.160F
16,5	82	143	18	176.165	176.165F
17	90	143	18	176.170	176.170F
17,5	92	143	18	176.175	176.175F
18	92	143	18	176.180	176.180F
18,5	100	153	20	176.185	176.185F
19	100	153	20	176.190	176.190F
19,5	100	153	20	176.195	176.195F
20	102	153	20	176.200	176.200F



Reibahlen - Aufbohrer
Reamers - Core drills

Inhaltsverzeichnis

Index

Werkzeug Gruppe 4: Reibahlen - Aufbohrer	Tools Group 4: Reamers - Core drills	Id. Nr. Code	Seite Page
Einführung	<i>Introduction</i>		269 ÷ 275

Werkzeug Gruppe 4.1:	Tools Group 4.1:	Id. Nr. Code	Seite Page
Reibahlen Linksdrall und Rechtsschneidend - Typ «B» Hartmetallsorte K10 - Feinstkorn - nach DIN 8093 (212) - ungleiche Teilung - Toleranz H7	<i>Reamers left hand spiral - right hand cut - Type «B» Tolerance H7 - DIN 8093 (212) - Uneven indexing - K10 - Micrograin carbide</i>	122	276
Reibahlen Linksdrall und Rechtsschneidend - Typ «B» Hartmetallsorte K10 - Feinstkorn - nach DIN 8093 (212) - ungleiche Teilung - Toleranz H7	<i>Reamers left hand spiral - right hand cut - Type «B» Tolerance H7 - DIN 8093 (212) - Uneven indexing - K10 - Micrograin carbide</i>	122	277
Reibahlen Geradegenutet - Typ «A» Hartmetallsorte K10 - Feinstkorn - Toleranz H7 - DIN 8093 (212) - ungleiche Teilung	<i>Straight flute reamers - Type «A» Tolerance H7 - K10 - Micrograin carbide - DIN 8093 (212) - Uneven indexing</i>	131	278
Reibahlen Linksdrall und Rechtsschneidend - Typ «B» Hartmetallsorte K10 - Feinstkorn - Toleranz H7	<i>Reamers left hand spiral - right hand cut - Type «B» Tolerance H7 - K10 - Micrograin carbide - Internal norm</i>	120	279
Reibahlen Rechtsdrall und Rechtsschnei- dend - Typ «C» Hartmetallsorte K10 - Feinstkorn - Toleranz H7	<i>Reamers right hand spiral - right hand cut - Type «C» Tolerance H7 - K10 - Micrograin carbide - Internal norm</i>	125	280

Reibahlen: Geometrie - Toleranzen und Schneidenteilung Reamers: geometry - tolerances and division of cutting edges

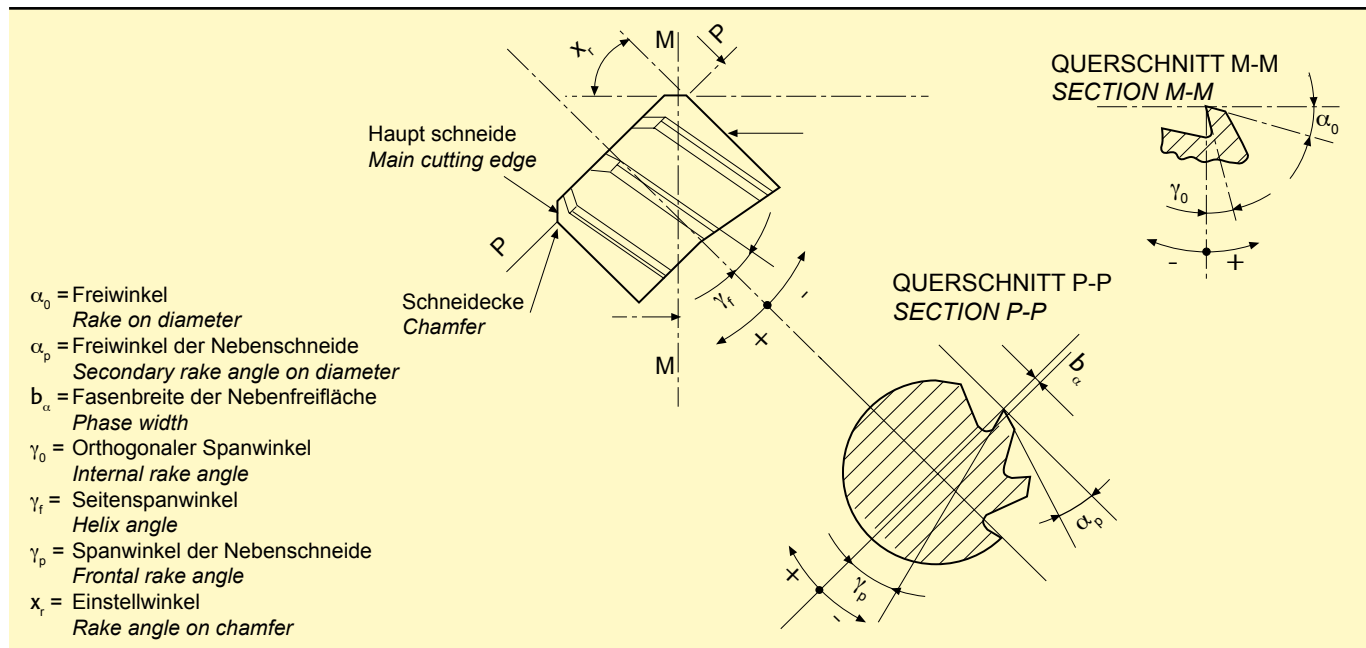

ungleiche Schneidenteilung uneven division of cutting edges

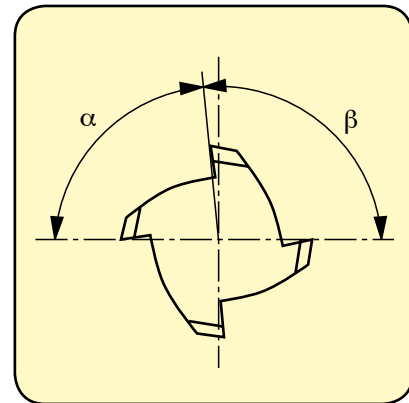
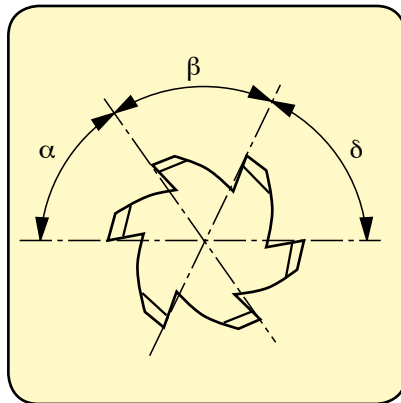
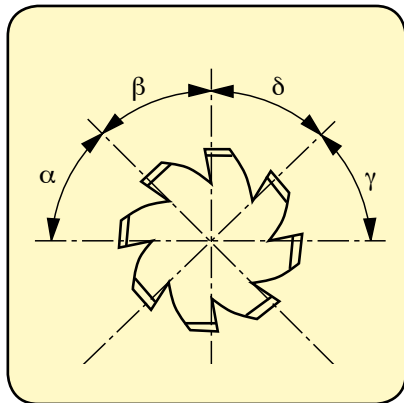



Schnittgeschwindigkeiten V_c (m/min) - Drehzahlen n (min^{-1})
Cutting speeds V_c (m/min) - Revolution per minute n (min^{-1})

Berechnungsformeln: Schnittgeschwindigkeit V_c (m/min) - Drehzahl n (min^{-1})
Calculation formula: Cutting speed V_c (m/min) - Revolution per minute n (min^{-1})

$$V_c \text{ (m/min)} = \frac{D_c \text{ (mm)} \times 3,14 \times n \text{ (min}^{-1}\text{)}}{1000}$$

$$n \text{ (min}^{-1}\text{)} = \frac{V_c \text{ (m/min)} \times 1000}{D_c \text{ (mm)} \times 3,14}$$

D_c (mm)	V_c (m/min)										
	5	8	10	12	15	20	25	30	35	40	45
	Drehzahl n (min^{-1}) / Revolution per minute n (min^{-1})										
2,00	796	1274	1592	1911	2389	3185	3981	4777	5573	6369	7166
2,50	637	1019	1274	1529	1911	2548	3185	3822	4459	5096	5732
3,00	531	849	1062	1274	1592	2123	2654	3185	3715	4246	4777
3,50	455	728	910	1092	1365	1820	2275	2730	3185	3640	4095
4,00	398	637	796	955	1194	1592	1990	2389	2787	3185	3583
4,50	354	566	708	849	1062	1415	1769	2123	2477	2831	3185
5,00	318	510	637	764	955	1274	1592	1911	2229	2548	2866
5,50	290	463	579	695	869	1158	1448	1737	2027	2316	2606
6,00	265	425	531	637	796	1062	1327	1592	1858	2123	2389
6,50	245	392	490	588	735	980	1225	1470	1715	1960	2205
7,00	227	364	455	546	682	910	1137	1365	1592	1820	2047
8,00	199	318	398	478	597	796	995	1194	1393	1592	1791
9,00	177	283	354	425	531	708	885	1062	1238	1415	1592
10,00	159	255	318	382	478	637	796	955	1115	1274	1433
11,00	145	232	290	347	434	579	724	869	1013	1158	1303
12,00	133	212	265	318	398	531	663	796	929	1062	1194
13,00	122	196	245	294	367	490	612	735	857	980	1102
14,00	114	182	227	273	341	455	569	682	796	910	1024
15,00	106	170	212	255	318	425	531	637	743	849	955
16,00	100	159	199	239	299	398	498	597	697	796	896
17,00	94	150	187	225	281	375	468	562	656	749	843
18,00	88	142	177	212	265	354	442	531	619	708	796
19,00	84	134	168	201	251	335	419	503	587	670	754
20,00	80	127	159	191	239	318	398	478	557	637	717
22,00	72	116	145	174	217	290	362	434	507	579	651
24,00	66	106	133	159	199	265	332	398	464	531	597
25,00	64	102	127	153	191	255	318	382	446	510	573

04

Reibahlen: Schnittgeschwindigkeit V_c (m/min) - Vorschubgeschwindigkeit f (mm)
Reamers: Cutting speed V_c (m/min) - Feed rate f (mm)

Werkstoff Gruppe Material group	Kühlmedium Code Cooling medium	$\diamond V_c$ (m/min)	Durchmesser D_c (mm) Diameter D_c (mm)										
			2,00	3,00	4,00	5,00	6,00	8,00	10,00	12,00	14,00	16,00	20,00
			f (mm)										
Aluminium - Alu-Legierungen - Kupfer - Kupferlegierungen - Magnesium <i>Aluminium - Alu-alloys - Copper - Copper alloys - Magnesium</i>													
A 1.1	1	35	0,10	0,12	0,14	0,15	0,18	0,20	0,25	0,28	0,30	0,34	0,38
A 1.2	1	25	0,10	0,12	0,14	0,15	0,18	0,20	0,25	0,28	0,30	0,34	0,38
A 1.3	1	30	0,10	0,12	0,14	0,15	0,18	0,20	0,25	0,28	0,30	0,34	0,38
A 1.4	1	25	0,10	0,12	0,14	0,15	0,18	0,20	0,24	0,26	0,28	0,32	0,35
A 1.5	1	25	0,10	0,12	0,14	0,15	0,18	0,20	0,24	0,26	0,28	0,32	0,35
A 1.6	1	30	0,08	0,10	0,12	0,14	0,16	0,20	0,24	0,26	0,28	0,32	0,35
A 1.7	0	20	0,06	0,08	0,10	0,10	0,12	0,15	0,18	0,20	0,22	0,25	0,28
A 2.1	1	30	0,10	0,12	0,14	0,15	0,18	0,20	0,24	0,26	0,28	0,32	0,35
A 2.2	1	30	0,10	0,12	0,14	0,15	0,18	0,20	0,24	0,26	0,28	0,32	0,35
A 2.3	2	40	0,10	0,12	0,14	0,15	0,18	0,20	0,24	0,26	0,28	0,32	0,35
A 2.4	1	30	0,08	0,10	0,12	0,14	0,16	0,20	0,24	0,26	0,28	0,32	0,35
A 2.5	2	40	0,08	0,10	0,12	0,14	0,16	0,20	0,24	0,26	0,28	0,32	0,35
A 2.6	1	25	0,08	0,10	0,12	0,14	0,16	0,20	0,24	0,26	0,28	0,32	0,35
A 2.7	1	25	0,08	0,10	0,12	0,14	0,16	0,18	0,20	0,24	0,25	0,28	0,32
A 3.1	1	25	0,10	0,12	0,15	0,18	0,20	0,22	0,25	0,28	0,32	0,35	0,40
A 3.2	1	25	0,10	0,12	0,15	0,18	0,20	0,22	0,25	0,28	0,32	0,35	0,40
A 4.1	3	30	0,10	0,10	0,12	0,14	0,16	0,18	0,20	0,22	0,25	0,28	0,32
A 4.2	3	30	0,10	0,10	0,12	0,14	0,16	0,18	0,20	0,22	0,25	0,28	0,32
Kunststoffe - Faserverstärkte Kunststoffe - Ne Werkstoffe <i>Plastics - Reinforced plastic fibers - Non ferrous materials</i>													
B 1.1	0	35	0,20	0,20	0,22	0,22	0,24	0,26	0,28	0,30	0,32	0,35	0,40
B 1.2	0	25	0,16	0,16	0,18	0,18	0,20	0,22	0,25	0,28	0,30	0,32	0,35
B 1.3	0	25	0,16	0,16	0,18	0,18	0,20	0,22	0,25	0,28	0,30	0,32	0,35
B 1.4	0	20	0,08	0,10	0,12	0,14	0,16	0,18	0,20	0,24	0,25	0,28	0,32
B 1.5	0	25	0,16	0,16	0,18	0,18	0,20	0,22	0,25	0,28	0,30	0,32	0,35
Allgemeine Stahlwerkstoffe - Stahllegierungen - gehärtete Stähle <i>General construction steels - Steel alloys - Hardened steels</i>													
C 1.1	1	25	0,15	0,16	0,16	0,18	0,18	0,20	0,22	0,25	0,28	0,32	0,36
C 1.2	1	25	0,15	0,16	0,16	0,18	0,18	0,20	0,22	0,25	0,28	0,32	0,36
C 1.3	1	25	0,14	0,15	0,15	0,16	0,16	0,18	0,20	0,22	0,25	0,28	0,32
C 1.4	1	25	0,14	0,15	0,15	0,16	0,16	0,18	0,20	0,22	0,25	0,28	0,32
C 1.5	1	25	0,14	0,15	0,15	0,16	0,16	0,18	0,20	0,22	0,25	0,28	0,32
C 1.6	2	20	0,12	0,14	0,14	0,15	0,15	0,16	0,18	0,20	0,22	0,25	0,30
C 1.7	0/3	12	0,08	0,08	0,10	0,10	0,10	0,12	0,14	0,15	0,18	0,20	0,25
C 1.8	1	15	0,08	0,08	0,10	0,10	0,10	0,12	0,14	0,15	0,18	0,20	0,25
C 2.1	1	15	0,08	0,08	0,10	0,10	0,10	0,12	0,14	0,15	0,18	0,20	0,25
C 2.2	1	15	0,08	0,08	0,10	0,10	0,10	0,12	0,14	0,15	0,18	0,20	0,25
C 2.3	2	15	0,08	0,08	0,10	0,10	0,10	0,12	0,14	0,15	0,18	0,20	0,25
C 2.4	1	10	0,06	0,06	0,08	0,08	0,10	0,10	0,12	0,14	0,16	0,18	0,22
C 3.1	1	10	0,06	0,06	0,08	0,08	0,10	0,10	0,12	0,14	0,16	0,18	0,22
C 3.2	2	8	0,04	0,04	0,05	0,05	0,06	0,80	0,10	0,12	0,15	0,16	0,20
C 4.1	1	12	0,08	0,08	0,10	0,10	0,10	0,12	0,14	0,15	0,18	0,20	0,25
C 4.2	2	10	0,06	0,06	0,08	0,08	0,10	0,10	0,12	0,14	0,16	0,18	0,22
Kühlmedium	0 = Trocken	1 = Emulsion	2 = Öl	3 = Luft									
Cooling medium	0= Dry	1= Emulsion	2= oil	3 = air									

04

\diamond Richtwerte für unbeschichtete Werkzeuge
 \diamond Approx. values for uncoated tools

Reibahlen: Schnittgeschwindigkeit V_c (m/min) - Vorschubgeschwindigkeit f (mm)
Reamers: Cutting speed V_c (m/min) - Feed rate f (mm)

Werkstoff Gruppe Material group	Kühlmedium Code Cooling medium	$\diamond V_c$ (m/min)	Durchmesser D_c (mm)										
			Diameter D_c (mm)										
			2,00	3,00	4,00	5,00	6,00	8,00	10,00	12,00	14,00	16,00	20,00
			f (mm)										
Rost- und säurebeständigeStähle - VA Stähle <i>Stainless steels</i>													
D 1.1	1	15	0,06	0,06	0,06	0,08	0,08	0,10	0,12	0,15	0,18	0,20	0,22
D 1.2	1	15	0,06	0,06	0,06	0,08	0,08	0,10	0,12	0,15	0,18	0,20	0,22
D 1.3	1	12	0,06	0,06	0,06	0,08	0,08	0,10	0,12	0,15	0,18	0,20	0,22
D 1.4	1	15	0,05	0,05	0,06	0,06	0,06	0,08	0,10	0,12	0,14	0,16	0,20
D 1.5	2	10	0,05	0,05	0,06	0,06	0,06	0,08	0,10	0,12	0,14	0,16	0,20
Nickel/Kobalt Legierungen - Titan - Titan Legierungen <i>Nickel/Cobalt alloys - Titanium - Titanium alloys</i>													
E 1.1	1	25	0,05	0,05	0,06	0,07	0,08	0,10	0,12	0,15	0,18	0,20	0,22
E 1.2	1	20	0,05	0,05	0,06	0,07	0,08	0,10	0,12	0,15	0,18	0,20	0,20
E 1.3	1	15	0,05	0,05	0,06	0,07	0,08	0,10	0,12	0,14	0,16	0,18	0,20
E 2.1	1	20	0,05	0,05	0,06	0,07	0,08	0,10	0,12	0,15	0,18	0,20	0,20
E 2.2	1	10	0,05	0,05	0,06	0,07	0,08	0,10	0,12	0,15	0,18	0,20	0,20
E 2.3	1	8	0,04	0,04	0,05	0,06	0,06	0,07	0,08	0,10	0,12	0,14	0,16
Gußwerkstoffe <i>Cast irons</i>													
F 1.1	0	12	0,08	0,10	0,14	0,18	0,22	0,25	0,28	0,32	0,35	0,38	0,40
F 1.2	0	12	0,10	0,12	0,14	0,15	0,16	0,18	0,20	0,24	0,28	0,32	0,35
F 1.3	3/0	5	0,04	0,04	0,05	0,06	0,06	0,07	0,08	0,10	0,12	0,14	0,16
F 1.4	0	15	0,08	0,10	0,14	0,18	0,22	0,25	0,28	0,32	0,35	0,38	0,40
F 1.5	0	15	0,10	0,12	0,14	0,15	0,16	0,18	0,20	0,24	0,28	0,32	0,35
F 2.1	3/0	12	0,08	0,10	0,14	0,18	0,22	0,25	0,28	0,32	0,35	0,38	0,40
F 2.2	3/0	10	0,06	0,06	0,06	0,08	0,08	0,10	0,12	0,15	0,18	0,20	0,22
F 2.3	3/0	10	0,10	0,12	0,14	0,15	0,16	0,18	0,20	0,22	0,24	0,26	0,30
F 2.4	3/0	10	0,10	0,12	0,14	0,15	0,16	0,18	0,20	0,22	0,24	0,26	0,30
Graphit - Wolfram/Kupferlegierungen (zur Elektrodenfertigung) <i>Graphite - Tungsten/copper alloys (for electrode manufacturing)</i>													
G 1.1													
G 2.1	1	12	0,10	0,12	0,14	0,15	0,18	0,20	0,24	0,26	0,28	0,32	0,35
Kühlmedium 0 = Trocken Cooling medium 0 = Dry			1 = Emulsion 1 = Emulsion			2 = Öl 2 = oil		3 = Luft 3 = air					

Wichtigste Herstellungstoleranzen - DIN 1420

Main manufacturing tolerances - DIN 1420

Nenn-durchmesser der Reibahle d_1 in mm		Zul. oberes und unteres Abmaß vom Nenndurchmesser d_1 der Reibahle in μm für Bohrungs-Toleranzfeld									
über	bis	A 9	A 11	B 8	B 9	B 10	B 11	C 8	C 9	C 10	C 11
1	3	+291	+321	+151	+161	+174	+191	+71	+81	+94	+111
		+282	+300	+146	+152	+160	+170	+66	+72	+80	+90
3	6	+295	+333	+155	+165	+180	+203	+85	+95	+110	+133
		+284	+306	+148	+154	+163	+176	+78	+84	+93	+106
6	10	+310	+356	+168	+180	+199	+226	+98	+110	+129	+156
		+297	+324	+160	+167	+178	+194	+90	+97	+108	+124
10	18	+326	+383	+172	+186	+209	+243	+117	+131	+154	+188
		+310	+344	+162	+170	+184	+204	+107	+115	+129	+149
18	30	+344	+410	+188	+204	+231	+270	+138	+154	+181	+220
		+325	+364	+176	+185	+201	+224	+126	+135	+151	+174
30	40	+362	+446	+203	+222	+255	+306	+153	+172	+205	+256
		+340	+390	+189	+200	+220	+250	+139	+150	+170	+200
40	50	+372	+456	+213	+232	+265	+316	+163	+182	+215	+266
		+350	+400	+199	+210	+230	+260	+149	+160	+180	+210
50	65	+402	+501	+229	+252	+292	+351	+179	+202	+242	+301
		+376	+434	+212	+226	+250	+284	+162	+176	+200	+234
65	80	+422	+521	+239	+262	+302	+361	+189	+212	+252	+311
		+396	+454	+222	+236	+260	+294	+172	+186	+210	+244
80	100	+453	+567	+265	+293	+339	+407	+215	+243	+289	+357
		+422	+490	+246	+262	+290	+330	+196	+212	+240	+280
100	120	+483	+597	+285	+313	+359	+427	+225	+253	+299	+367
		+452	+520	+266	+282	+310	+350	+206	+222	+250	+290
120	140	+545	+672	+313	+345	+396	+472	+253	+285	+336	+412
		+510	+584	+290	+310	+340	+384	+230	+250	+280	+324
140	160	+605	+732	+333	+365	+416	+492	+263	+295	+346	+422
		+570	+644	+310	+330	+360	+404	+240	+260	+290	+334
160	180	+665	+792	+363	+395	+446	+522	+283	+315	+366	+442
		+630	+704	+340	+360	+390	+434	+260	+280	+310	+354

04

Nenn-durchmesser der Reibahle d_1 in mm		Zul. oberes und unteres Abmaß vom Nenndurchmesser d_1 der Reibahle in μm für Bohrungs-Toleranzfeld												
über	bis	D 8	D 9	D 10	D 11	E 7	E 8	E 9	F 6	F 7	F 8	F 9	G 6	G 7
1	3	+31	+41	+54	+71	+22	+25	+35	+11	+14	+17	+27	+7	+10
		+26	+32	+40	+50	+18	+20	+26	+8	+10	+12	+18	+4	+6
3	6	+45	+55	+70	+93	+30	+35	+45	+16	+20	+25	+35	+10	+14
		+38	+44	+53	+66	+25	+28	+34	+13	+15	+18	+24	+7	+9
6	10	+58	+70	+89	+116	+37	+43	+55	+20	+25	+31	+43	+12	+17
		+50	+57	+68	+84	+31	+35	+42	+16	+19	+23	+30	+8	+11
10	18	+72	+86	+109	+143	+47	+54	+68	+25	+31	+38	+52	+15	+21
		+62	+70	+84	+104	+40	+44	+52	+21	+24	+28	+36	+11	+14
18	30	+93	+109	+136	+175	+57	+68	+84	+31	+37	+48	+64	+18	+24
		+81	+90	+106	+129	+49	+56	+65	+26	+29	+36	+45	+13	+16
30	50	+113	+132	+165	+216	+71	+83	+102	+38	+46	+58	+77	+22	+30
		+99	+110	+130	+160	+62	+69	+80	+32	+37	+44	+55	+16	+21
50	80	+139	+162	+202	+261	+85	+99	+122	+46	+55	+69	+92	+26	+35
		+122	+136	+160	+194	+74	+82	+96	+39	+44	+52	+66	+19	+24
80	120	+165	+193	+239	+307	+101	+117	+145	+54	+65	+81	+109	+30	+41
		+146	+162	+190	+230	+88	+98	+114	+46	+52	+62	+78	+22	+28
120	180	+198	+230	+281	+357	+119	+138	+170	+64	+77	+96	+128	+35	+48
		+175	+195	+225	+269	+105	+115	+135	+55	+63	+73	+93	+26	+34



Wichtigste Herstellungstoleranzen - DIN 1420
Main manufacturing tolerances - DIN 1420

Nenn-durchmesser der Reibahle d_1 in mm		Zul. oberes und unteres Abmaß vom Nenndurchmesser d_1 der Reibahle in μm für Bohrungs-Toleranzfeld													
über	bis	H 6	H 7	H 8	H 9	H 10	H 11	H 12	J 6	J 7	J 8	JS 6	JS 7	JS 8	JS 9
1	3	+ 5	+ 8	+ 11	+ 21	+ 34	+ 51	+ 85	+ 1	+ 2	+ 3	+ 2	+ 3	+ 4	+ 8
		+ 2	+ 4	+ 6	+ 12	+ 20	+ 30	+ 50	- 2	- 2	- 2	- 1	- 1	- 1	- 1
3	6	+ 6	+ 10	+ 15	+ 25	+ 40	+ 63	+102	+ 3	+ 4	+ 7	+ 2	+ 4	+ 6	+ 10
		+ 3	+ 5	+ 8	+ 14	+ 23	+ 36	+ 60	0	- 1	0	- 1	- 1	- 1	- 1
6	10	+ 7	+ 12	+ 18	+ 30	+ 49	+ 76	+127	+ 3	+ 5	+ 8	+ 3	+ 5	+ 7	+ 12
		+ 3	+ 6	+ 10	+ 17	+ 28	+ 44	+ 74	- 1	- 1	0	- 1	- 1	- 1	- 1
10	18	+ 9	+ 15	+ 22	+ 36	+ 59	+ 93	+153	+ 4	+ 7	+ 10	+ 3	+ 6	+ 9	+ 15
		+ 5	+ 8	+ 12	+ 20	+ 34	+ 54	+ 90	0	0	0	- 1	- 1	- 1	- 1
18	30	+ 11	+ 17	+ 28	+ 44	+ 71	+110	+178	+ 6	+ 8	+ 15	+ 4	+ 7	+ 11	+ 18
		+ 6	+ 9	+ 16	+ 25	+ 41	+ 64	+104	+ 1	0	+ 3	- 1	- 1	- 1	- 1
30	50	+ 13	+ 21	+ 33	+ 52	+ 85	+136	+212	+ 7	+ 10	+ 18	+ 5	+ 8	+ 13	+ 21
		+ 7	+ 12	+ 19	+ 30	+ 50	+ 80	+124	+ 1	+ 1	+ 4	- 1	- 1	- 1	- 1
50	80	+ 16	+ 25	+ 39	+ 62	+102	+161	+255	+ 10	+ 13	+ 21	+ 6	+ 10	+ 16	+ 25
		+ 9	+ 14	+ 22	+ 36	+ 60	+ 94	+150	+ 3	+ 2	+ 4	- 1	- 1	- 1	- 1
80	120	+ 18	+ 29	+ 45	+ 73	+119	+187	+297	+ 12	+ 16	+ 25	+ 7	+ 12	+ 18	+ 30
		+ 10	+ 16	+ 26	+ 42	+ 70	+110	+174	+ 4	+ 3	+ 6	- 1	- 1	- 1	- 1
120	180	+ 21	+ 34	+ 53	+ 85	+136	+212	+340	+ 14	+ 20	+ 31	+ 8	+ 14	+ 22	+ 35
		+ 12	+ 20	+ 30	+ 50	+ 80	+124	+200	+ 5	+ 6	+ 8	- 1	0	- 1	0

04

Nenn-durchmesser der Reibahle d_1 in mm		Zul. oberes und unteres Abmaß vom Nenndurchmesser d_1 der Reibahle in μm für Bohrungs-Toleranzfeld													
über	bis	K 6	K 7	K 8	M 6	M 7	M 8	N 6	N 7	N 8	N 9	N 10	N 11	P 6	P 7
1	3	- 4	- 2	- 3	- 3	- 4	-	- 5	- 6	- 7	- 8	- 10	- 13	- 7	- 8
		- 1	- 6	- 8	- 6	- 8	-	- 8	- 10	- 12	- 17	- 24	- 34	- 10	- 12
3	6	0	+ 1	+ 2	- 3	- 2	- 1	- 7	- 6	- 5	- 5	- 8	- 12	- 11	- 10
		- 3	- 4	- 5	- 6	- 7	- 8	- 10	- 11	- 12	- 16	- 25	- 39	- 14	- 15
6	10	0	+ 2	+ 2	- 5	- 3	- 3	- 9	- 7	- 7	- 6	- 9	- 14	- 14	- 12
		- 4	- 4	- 6	- 9	- 9	- 11	- 13	- 13	- 15	- 19	- 30	- 46	- 18	- 18
10	18	0	+ 3	+ 3	- 6	- 3	- 3	- 11	- 8	- 8	- 7	- 11	- 17	- 17	- 14
		- 4	- 4	- 7	- 10	- 10	- 13	- 15	- 15	- 18	- 23	- 36	- 56	- 21	- 21
18	30	0	+ 2	+ 5	- 6	- 4	- 1	- 13	- 11	- 8	- 8	- 13	- 20	- 20	- 18
		- 5	- 6	- 7	- 11	- 12	- 13	- 18	- 19	- 20	- 27	- 43	- 66	- 25	- 26
30	50	0	+ 3	+ 6	- 7	- 4	- 1	- 15	- 12	- 9	- 10	- 15	- 24	- 24	- 21
		- 6	- 6	- 8	- 13	- 13	- 15	- 21	- 21	- 23	- 32	- 50	- 80	- 30	- 30
50	80	+ 1	+ 4	+ 7	- 8	- 5	- 2	- 17	- 14	- 11	- 12	- 18	- 29	- 29	- 26
		- 6	- 7	- 10	- 15	- 16	- 19	- 24	- 24	- 28	- 38	- 60	- 96	- 36	- 37
80	120	0	+ 4	+ 7	- 10	- 6	- 3	- 20	- 16	- 13	- 14	- 21	- 33	- 34	- 30
		- 8	- 9	- 12	- 18	- 19	- 22	- 28	- 29	- 32	- 45	- 70	- 110	- 42	- 43
120	180	0	+ 6	+ 10	- 12	- 6	- 2	- 24	- 18	- 14	- 15	- 24	- 38	- 40	- 34
		- 9	- 8	- 13	- 21	- 20	- 25	- 33	- 32	- 37	- 50	- 80	- 126	- 49	- 48

PIKTOGRAMME (SYMBOLE) ERKLÄRUNG ICONS DESCRIPTION

Hartmetall Qualität <i>Carbide grade</i>		Werkzeug - Länge <i>Tool length</i>	
Werkzeugausführung nach Werksnorm <i>Cutting edge design acc. to internal standard</i>		Werkzeug - Länge <i>Tool length</i>	
Werksnorm (WN) lang <i>Internal standard long</i>		Werkzeugtyp A <i>Tool type A</i>	
Werkzeugbaumaße nach DIN <i>Dimensions acc. to DIN 8093</i>		Werkzeugtyp B <i>Tool type B</i>	
Kühlkanäle gedraht <i>Spiral coolant ducts</i>		Werkzeugtyp C <i>Tool type C</i>	
Kühlkanäle gerade, zentrisch <i>Straight centric coolant duct</i>			
Kühlkanäle gerade <i>Straight coolant ducts</i>			
mit Emulsion - Öl <i>with oil emulsion</i>			
gerade genutet <i>straight flute</i>			
Linksspirale - rechtsschneidend <i>Left hand cut spiral - right hand cut</i>			
Rechtsspirale - rechtsschneidend <i>Right hand cut spiral - right hand cut</i>			
Werkzeugdurchmesser D _c <i>Tool diameter D_c</i>			
Werkzeug - Länge <i>Tool length</i>			

Reibahlen Linksdrill und Rechtsschneidend - Typ «B»

Hartmetallsorte K10 - Feinstkorn - nach DIN 8093 (212) - ungleiche Teilung - Toleranz H7

Reamers left hand spiral - right hand cut - Type «B»

Tolerance H7 - DIN 8093 (212) - Uneven indexing - K10 - Micrograin carbide

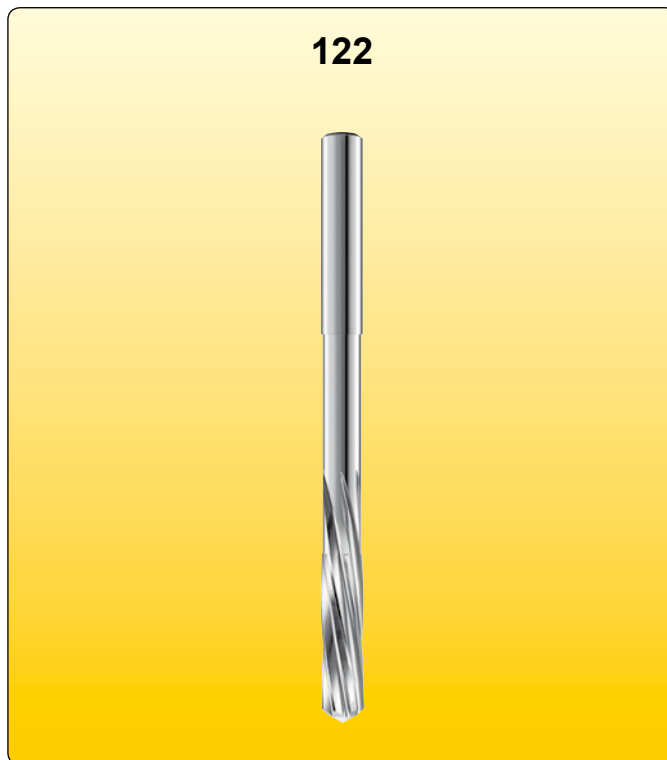

Einsatzgebiete / Range of application

A: Legierungen / Light alloys
A1.1-1.7 A2.1-2.7 A3.1-3.2 A4.1-4.2

C: Stahlwerkstoffe / Steels
C1.1-1.8 C2.1-2.4 C3.1 C4.1-4.2

D: Edelstahl / Stainless Steel
D1.1-1.5

E: Titan / Titanium
E1.1-1.3 E2.2

F: Gußeisen / Cast irons
F1.1-1.5 F2.1-2.4

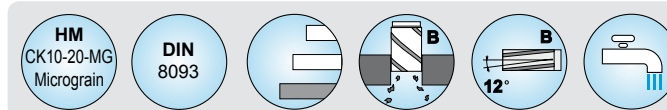
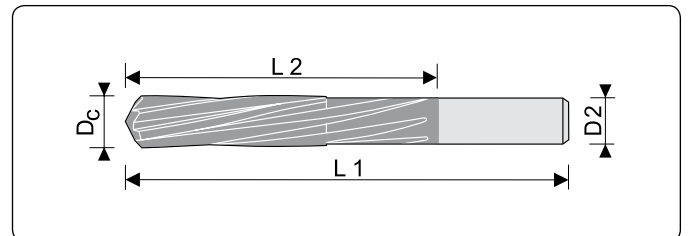

4.
01

D _c mm von-bis / from-to Toll. H7	L2	L1	D2	Z	122
					■
					Bitte immer - Ø mm angeben / Please always indicate Ø mm
1,9 - 2,1	11	49	2	4	122.0190 ÷ 122.0210
2,2 - 2,3	12	53	2,2	4	122.0220 ÷ 122.0230
2,4 - 2,6	14	57	2,5	4	122.0240 ÷ 122.0260
2,7 - 3,1	15	61	3	4	122.0270 ÷ 122.0310
3,2 - 3,7	18	70	3,5	4	122.0320 ÷ 122.0370
3,8 - 4,2	19	75	4	4	122.0380 ÷ 122.0420
4,3 - 4,7	21	75	4,5	4	122.0430 ÷ 122.0470
4,8 - 5,3	23	86	5	4	122.0480 ÷ 122.0530
5,4 - 5,8	26	93	5,6	6	122.0540 ÷ 122.0580
5,9 - 6,2	26	93	5,6	6	122.0590 ÷ 122.0620
6,3 - 6,7	28	101	6,3	6	122.0630 ÷ 122.0670
6,8 - 7,5	31	109	7,1	6	122.0680 ÷ 122.0750
7,6 - 8,5	33	117	8	6	122.0760 ÷ 122.0850
8,6 - 9,5	36	125	9	6	122.0860 ÷ 122.0950
9,6 - 10,6	38	133	10	6	122.0960 ÷ 122.1060
10,7 - 11,8	41	142	10	6	122.1070 ÷ 122.1180
11,9 - 13,2	44	151	10	6	122.1190 ÷ 122.1320

- Auf Anfrage auch mit Beschichtung lieferbar.
- Coating upon request.

Reibahlen Linksdrall und Rechtsschneidend - Typ «B»

Hartmetallsorte K10 - Feinstkorn - nach DIN 8093 (212) - ungleiche Teilung - Toleranz H7

Reamers left hand spiral - right hand cut - Type «B»

Tolerance H7 - DIN 8093 (212) - Uneven indexing - K10 - Micrograin carbide

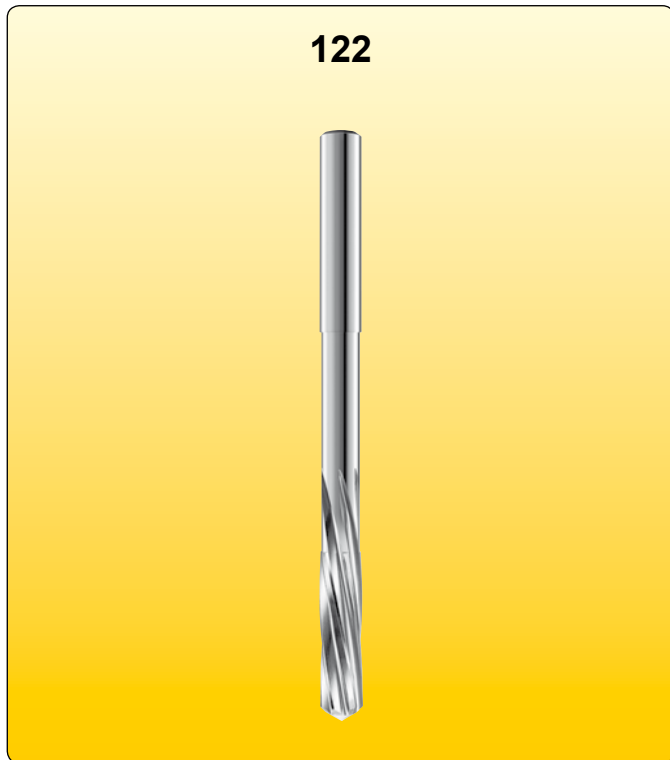

Einsatzgebiete / Range of application

A: Legierungen / Light alloys

A1.1-1.7 A2.1-2.7 A3.1-3.2 A4.1-4.2

C: Stahlwerkstoffe / Steels

C1.1-1.8 C2.1-2.4 C3.1 C4.1-4.2

D: Edelstahl / Stainless Steel

D1.1-1.5

E: Titan / Titanium

E1.1-1.3 E2.2

F: Gußeisen / Cast irons

F1.1-1.5 F2.1-2.4

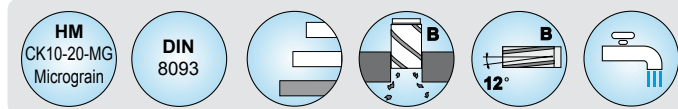
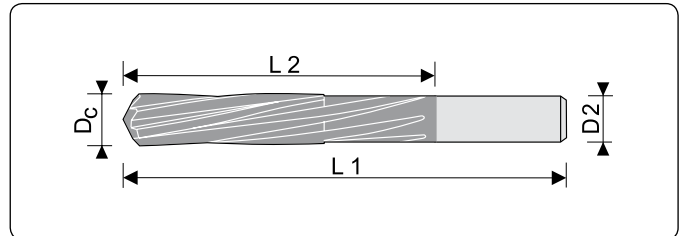

4.01

D _c mm von-bis / from-to H7	L2	L1	D2	Z	122	
					□	
					Bitte immer - Ø mm angeben / Please always indicate Ø mm	
1,91 - 2,12	11	49	2	4	122.0191 ÷ 122.0212	
2,13 - 2,36	12	53	2,2	4	122.0213 ÷ 122.0236	
2,37 - 2,65	14	57	2,5	4	122.0237 ÷ 122.0265	
2,66 - 3,15	15	61	3	4	122.0266 ÷ 122.0315	
3,16 - 3,75	18	70	3,5	4	122.0316 ÷ 122.0375	
3,76 - 4,25	19	75	4	4	122.0376 ÷ 122.0425	
4,26 - 4,75	21	75	4,5	4	122.0426 ÷ 122.0475	
4,76 - 5,30	23	86	5	4	122.0476 ÷ 122.0530	
5,31 - 5,80	26	93	5,6	6	122.0531 ÷ 122.0580	
5,81 - 6,20	26	93	5,6	6	122.0581 ÷ 122.0620	
6,21 - 6,70	28	101	6,3	6	122.0621 ÷ 122.0670	
6,71 - 7,50	31	109	7,1	6	122.0671 ÷ 122.0750	
7,51 - 8,50	33	117	8	6	122.0751 ÷ 122.0850	
8,51 - 9,50	36	125	9	6	122.0851 ÷ 122.0950	
9,51 - 10,60	38	133	10	6	122.0951 ÷ 122.1060	
10,61 - 11,80	41	142	10	6	122.1061 ÷ 122.1180	
11,81 - 13,20	44	151	10	6	122.1181 ÷ 122.1320	

- Auf Anfrage auch mit Beschichtung lieferbar.
- Coating upon request.

Reibahlen Geradegenutet - Typ «A»

Hartmetallsorte K10 - Feinstkorn - Toleranz H7 - DIN 8093 (212) - ungleiche Teilung

Straight flute reamers - Type «A»

Tolerance H7 - K10 - Micrograin carbide - DIN 8093 (212) - Uneven indexing

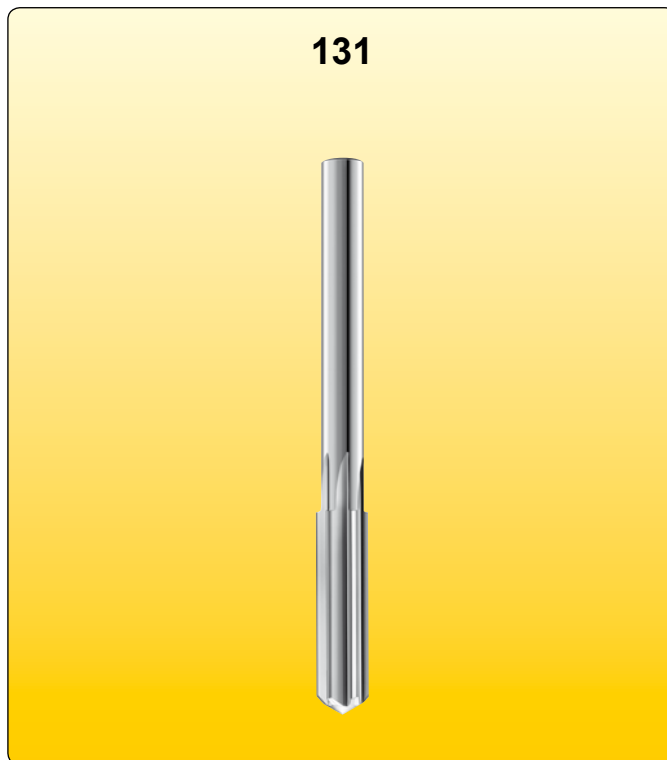

Einsatzgebiete / Range of application

A: Legierungen / Light alloys

A1.1-1.7 A2.1-2.7 A3.1-3.2 A4.1-4.2

C: Stahlwerkstoffe / Steels

C1.1-1.8 C2.1-2.4 C3.1 C4.1-4.2

D: Edelstahl / Stainless Steel

D1.1-1.5

E: Titan / Titanium

E1.1-1.3 E2.2

F: Gußeisen / Cast irons

F1.1-1.5 F2.1-2.4

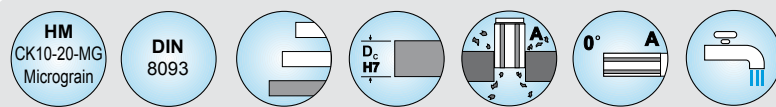
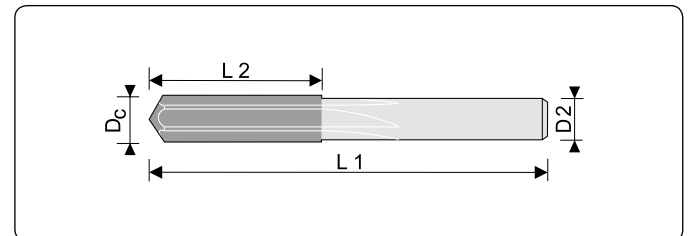

4.
01

D _c H7	L2	L1	D2 h6	Z	131
					□
2	11	49	2	4	131.020
2,5	14	57	2,5	4	131.025
3	15	61	3	4	131.030
3,5	18	70	3,5	4	131.035
4	19	75	4	4	131.040
4,5	21	75	4,5	4	131.045
5	23	86	5	4	131.050
5,5	26	93	5,6	6	131.056
6	26	93	5,6	6	131.056
6,5	28	101	6,3	6	131.063
7	31	109	7,1	6	131.071
8	33	117	8	6	131.080
9	36	125	9	6	131.090
10	38	133	10	6	131.100
11	41	142	10	6	131.110
12	44	151	10	6	131.120

□ Auf Anfrage auch mit Beschichtung lieferbar.

□ Coating upon request.

Reibahlen Linksdrall und Rechtsschneidend - Typ «B»

Hartmetallsorte K10 - Feinstkorn - Toleranz H7

Reamers left hand spiral - right hand cut - Type «B»

Tolerance H7 - K10 - Micrograin carbide - Internal norm

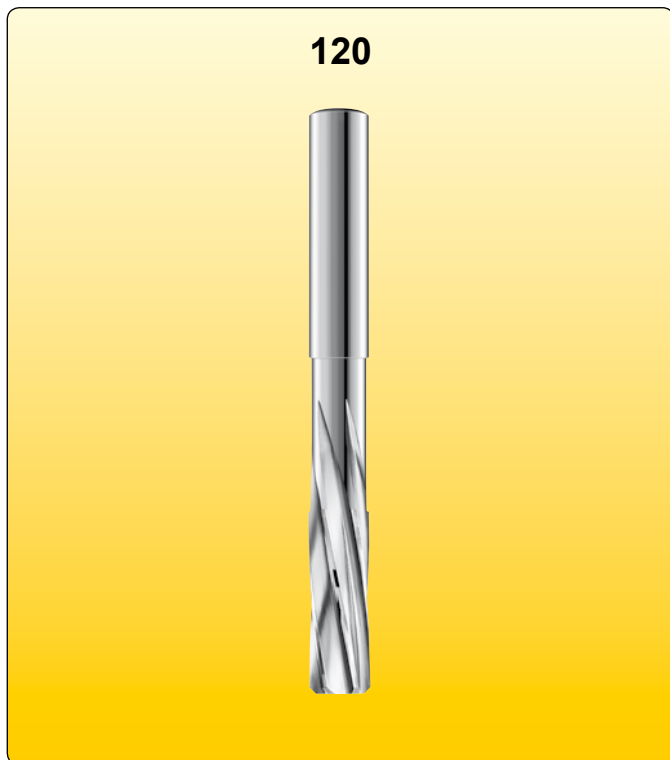

Einsatzgebiete / Range of application

A: Legierungen / Light alloys

A1.1-1.7 A2.1-2.7 A3.1-3.2 A4.1-4.2

C: Stahlwerkstoffe / Steels

C1.1-1.8 C2.1-2.4 C3.1 C4.1-4.2

D: Edelstahl / Stainless Steel

D1.1-1.5

E: Titan / Titanium

E1.1-1.3 E2.2

F: Gußeisen / Cast irons

F1.1-1.5 F2.1-2.4

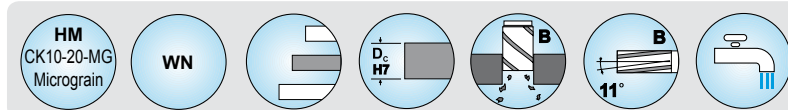
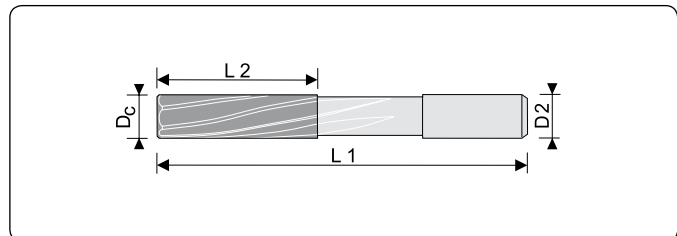

D _c H7	L2	L1	D2	Z	120
					□
2	12	40	2	4	120.020
2,5	12	40	2,5	4	120.025
3	12	50	3	4	120.030
3,5	15	52	3,5	4	120.035
4	18	55	4	4	120.040
4,5	20	58	4,5	4	120.045
5	22	62	5	4	120.050
5,5	22	62	5,5	4	120.055
6	25	66	6	6	120.060
6,5	25	66	6,5	6	120.065
7	25	75	7	6	120.070
8	28	79	8	6	120.080
9	35	100	9	6	120.090
10	35	100	10	6	120.100
11	35	100	11	6	120.110
12	35	100	12	6	120.120

□ Auf Anfrage auch mit Beschichtung lieferbar.

■ Coating upon request.

Reibahlen Rechtsdrill und Rechtsschneidend - Typ «C»

Hartmetallsorte K10 - Feinstkorn - Toleranz H7

Reamers right hand spiral - right hand cut - Type «C»

Tolerance H7 - K10 - Micrograin carbide - Internal norm

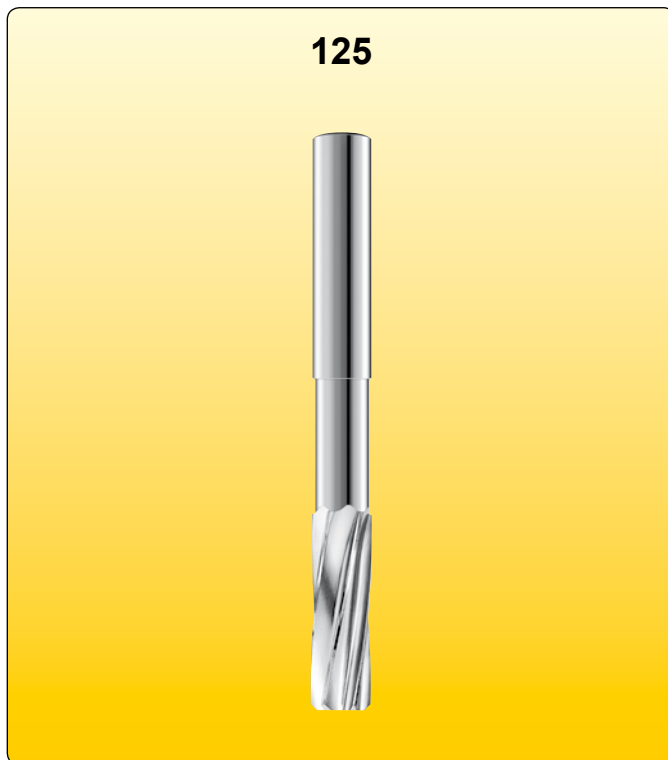

Einsatzgebiete / Range of application

A: Legierungen / Light alloys

A1.1-1.7 A2.1-2.7 A3.1-3.2 A4.1-4.2

C: Stahlwerkstoffe / Steels

C1.1-1.8 C2.1-2.4 C3.1 C4.1-4.2

D: Edelstahl / Stainless Steel

D1.1-1.5

E: Titan / Titanium

E1.1-1.3 E2.2

F: Gußeisen / Cast irons

F1.1-1.5 F2.1-2.4

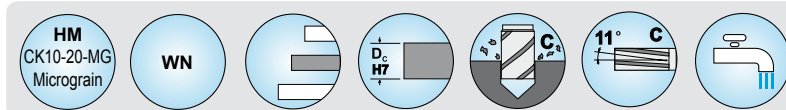
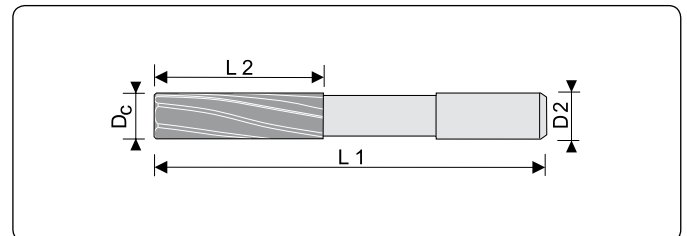

4.
01

D _c H7	L2	L1	D2 h7	Z	125
					□
2	12	40	2	4	125.020
2,5	12	40	2,5	4	125.025
3	12	50	3	4	125.030
3,5	15	52	3,5	4	125.035
4	18	55	4	4	125.040
4,5	20	58	4,5	4	125.045
5	22	62	5	4	125.050
5,5	22	62	5,5	4	125.055
6	25	66	6	6	125.060
6,5	25	66	6,5	6	125.065
7	25	75	7	6	125.070
8	28	79	8	6	125.080
9	35	100	9	6	125.090
10	35	100	10	6	125.100
11	35	100	11	6	125.110
12	35	100	12	6	125.120

□ Auf Anfrage auch mit Beschichtung lieferbar.

□ Coating upon request.



Hartmetall - Kegelsenker
Carbide countersinks



Inhaltsverzeichnis Index

Werkzeug Gruppe 5: Hartmetall - Kegelsenker	Tools Group 5: Carbide countersinks	Id. Nr. Code	Seite Page
Einführung	<i>Introduction</i>		282 ÷ 285
Kegelsenker - 1 Schneide - 60°	<i>60° single flute countersink</i>	51 51A	286
Kegelsenker - 3 Schneiden - 60°	<i>60° three flute countersink</i>	53 53A	287
Kegelsenker - 1 Schneide - 90°	<i>90° single flute countersink</i>	50 50A	288
Kegelsenker - 3 Schneiden - 90°	<i>90° three flute countersink</i>	52 52A	289

Schnittgeschwindigkeit V_c (m/min) - Vorschubgeschwindigkeit f (mm)
Cutting speed V_c (m/min) - Feed rate f (mm)

Werkstoff Gruppe	Werkstoff Bezeichnung	Festigkeit N/mm ²	V_c (m/min)	f (mm)	Kühlung
Material Group	Material Description	Strength N/mm ²	V_c (m/min)	f (mm)	Cooling system
A 1	Alu Knetlegierungen <i>Wrought Aluminium alloys</i>	< 705	25 - 30	0,08 - 0,3	Emulsion <i>Emulsion</i>
	Alu Gußlegierungen Si < 12% <i>Cast aluminium alloys</i>	< 400	30 - 35	0,1 - 0,3	Emulsion <i>Emulsion</i>
A 2	Kupfer Kupferlegierungen <i>Copper - Copper alloys</i>	< 400	30 - 35	0,1 - 0,3	Emulsion <i>Emulsion</i>
	Kupfer - Kupferlegierungen <i>Copper - Copper alloys</i>	< 850	20 - 25	0,05 - 0,20	Emulsion <i>Emulsion</i>
A 4	Magnesiumlegierungen <i>Magnesium alloys</i>	< 705	25 - 30	0,05 - 0,25	Trocken <i>Dry</i>
B 1	Duroplaste - Thermoplaste <i>Thermoset - Thermoplastic</i>	< 250	30 - 35	0,08 - 0,35	Trocken / Luft <i>Dry / Air</i>
B 2	Ne Werkstoffe <i>Non ferrous materials</i>	< 250	20 - 30	0,08 - 0,15	Trocken / Luft <i>Dry / Air</i>
C 1	Stahl - Legierte Stähle <i>Steel - Steel alloys</i>	< 400	20 - 25	0,1 - 0,3	Emulsion <i>Emulsion</i>
	Stahl - Legierte Stähle <i>Steel - Steel alloys</i>	< 705	15 - 20	0,05 - 0,25	Emulsion <i>Emulsion</i>
	Stahl - Legierte Stähle <i>Steel - Steel alloys</i>	< 1125	12 - 18	0,05 - 0,20	Emulsion <i>Emulsion</i>
	Stahl - Legierte Stähle <i>Steel - Steel alloys</i>	< 1420	10 - 15	0,03 - 0,15	Schneidöl <i>Oil</i>
C 2	Gehärtete Stähle <i>Hardned steels</i>	< 56 HRC	8 - 12	0,02 - 0,01	Schneidöl <i>Oil</i>
C 3	Stahl Sonderwerkstoffe <i>Special steels</i>	< 1420	10 - 15	0,03 - 0,15	Schneidöl <i>Oil</i>
D 1	Rostbeständige Stähle <i>Stainless steels</i>	< 850	10 - 15	0,06 - 0,25	Emulsion <i>Emulsion</i>
	Säurebeständige Stähle <i>Stainless steels</i>	< 1420	8 - 12		Schneidöl <i>Oil</i>
E 1	Reintitan <i>Pure titanium</i>	< 705	20 - 25	0,05 - 0,20	Emulsion <i>Emulsion</i>
	Titanlegierungen <i>Titanium alloys</i>	< 1125	15 - 20	0,05 - 0,20	Emulsion <i>Emulsion</i>
E 2	Nickel-Kobaltlegierungen <i>Nickel-cobalt alloys</i>	< 705	20 - 25	0,05 - 0,20	Emulsion <i>Emulsion</i>
	Nickel-Kobaltlegierungen <i>Nickel-cobalt alloys</i>	< 1420	8 - 12	0,03 - 0,15	Schneidöl <i>Oil</i>
F 1	Grauguß <i>Grey cast irons</i>	< 333 HB	15 - 20	0,05 - 0,3	Trocken <i>Dry</i>
	Hartguß <i>Hard cast irons</i>	< 418 HB	8 - 12	0,03 - 0,15	Trocken / MMS <i>Dry / Min.q.ty lubr.</i>
	Temperguß <i>Malleable cast irons</i>	< 705	15 - 20	0,05 - 0,25	Trocken <i>Dry</i>
F 2	Gußeisen mit Kugelgraphit <i>Nodular graphite cast irons</i>	< 400	20 - 25	0,05 - 0,3	Trocken / MMS <i>Dry / Min.q.ty lubr.</i>
	Gußeisen mit Kugelgraphit <i>Nodular graphite cast irons</i>	< 1125	15 - 20	0,03 - 0,2	Trocken / MMS <i>Dry / Min.q.ty lubr.</i>
	Gußeisen mit Vermikulargraphit <i>Vermicular graphite cast irons</i>	< 333 HB	15 - 20	0,03 - 0,2	Trocken / MMS <i>Dry / Min.q.ty lubr.</i>

Kegelsenker Berechnungsformeln für Drehzahl n (min^{-1})

Calculation formula for revolution per minute n (min^{-1})

Drehzahl n (min^{-1}) Revolution per minute n (min^{-1})	Schnittgeschwindigkeit V_c (m/min) Cutting speed V_c (m/min)
$n \text{ (min}^{-1}\text{)} = \frac{V_c \times 1000}{D_w \times 3,14}$	$V_c \text{ (m/min)} = \frac{D_w \times 3,14 \times n \text{ (min}^{-1}\text{)}}{1000}$

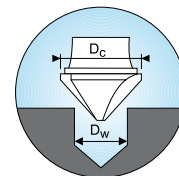









Drehzahlenübersicht n (min^{-1})

Survey of revolutions per minute n (min^{-1})

D_w (mm)	V_c (m/min)											
	5	8	10	12	15	18	20	25	30	35	40	50
Drehzahl n (min^{-1}) / Revolution or minute (min^{-1})												
2,5	39	63	79	94	118	141	157	196	236	275	314	393
3,0	47	75	94	113	141	170	188	236	283	330	377	471
3,5	55	88	110	132	165	198	220	275	330	385	440	550
4,0	63	100	126	151	188	226	251	314	377	440	502	628
5,0	79	126	157	188	236	283	314	393	471	550	628	785
5,5	86	138	173	207	259	311	345	432	518	604	691	864
6,0	94	151	188	226	283	339	377	471	565	659	754	942
6,5	102	163	204	245	306	367	408	510	612	714	816	1021
7,0	110	176	220	264	330	396	440	550	659	769	879	1099
7,5	118	188	236	283	353	424	471	589	707	824	942	1178
8,0	126	201	251	301	377	452	502	628	754	879	1005	1256
8,5	133	214	267	320	400	480	534	667	801	934	1068	1335
9,0	141	226	283	339	424	509	565	707	848	989	1130	1413
9,5	149	239	299	358	448	538	597	747	896	1045	1194	1493
10,0	157	251	314	377	471	565	628	785	942	1099	1256	1570
11,0	173	276	345	414	518	622	691	864	1036	1209	1382	1727
12,0	188	301	377	452	565	678	754	942	1130	1319	1507	1884
13,0	204	327	408	490	612	735	816	1021	1225	1429	1633	2041
14,0	220	352	440	528	659	791	879	1099	1319	1539	1758	2198
15,0	236	377	471	565	707	848	942	1178	1413	1649	1884	2355
16,0	251	402	502	603	754	904	1005	1256	1507	1758	2010	2512
17,0	267	427	534	641	801	961	1068	1335	1601	1868	2135	2669
18,0	283	452	565	678	848	1017	1130	1413	1696	1978	2261	2826
9,0	141	226	283	339	424	509	565	707	848	989	1130	1413
20,0	314	502	628	754	942	1130	1256	1570	1884	2198	2512	3140
22,0	345	553	691	829	1036	1243	1382	1727	2072	2418	2763	3454
24,0	377	603	754	904	1130	1356	1507	1884	2261	2638	3014	3768
26,0	408	653	816	980	1225	1470	1633	2041	2449	2857	3266	4082
28,0	440	703	879	1055	1319	1583	1758	2198	2638	3077	3517	4396
30,0	471	754	942	1130	1413	1696	1884	2355	2826	3297	3768	4710
31,5	495	791	989	1187	1484	1780	1978	2473	2967	3462	3956	4946

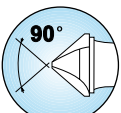
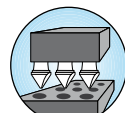
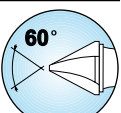
PIKTOGRAMME (SYMBOLE) ERKLÄRUNG

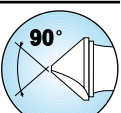
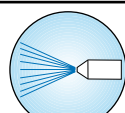
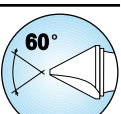
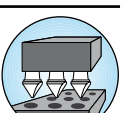
ICONS DESCRIPTION

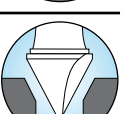
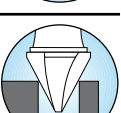
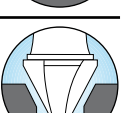
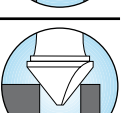
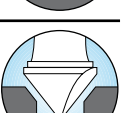
Hartmetall Qualität <i>Carbide grade</i>		Bearbeitung - Anfasen <i>Face setting application</i>	
Werkzeugausführung nach Werksnorm <i>Cutting edge design acc. to internal standard</i>		Bearbeitung - Senken <i>Countersinking application</i>	
Dreischneider 90° <i>90° three flute</i>		Mehrspindelbearbeitung <i>Multi-spindle application</i>	
Dreischneider 60° <i>60° three flute</i>		mit Emulsion <i>with emulsion</i>	
Einschneider 90° <i>90° single flute</i>		mit Druckluft <i>with compressed air</i>	
Einschneider 60° <i>60° single flute</i>			
Mehrspindelbearbeitung <i>Multi-spindle application</i>			
Bearbeitung - Anfasen <i>Face setting application</i>			
Bearbeitung - Senken <i>Countersinking application</i>			
Bearbeitung - Anfasen <i>Face setting application</i>			
Bearbeitung - Senken <i>Countersinking application</i>			
Bearbeitung - Anfasen <i>Face setting application</i>			
Bearbeitung - Senken <i>Countersinking application</i>			

Kegelsenker - 3 Schneiden - 60°

60° three flute countersink

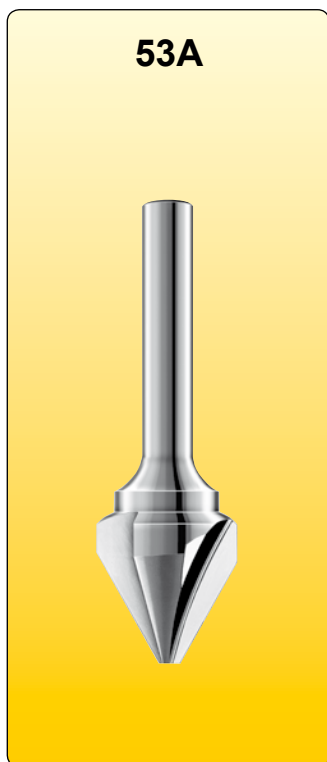
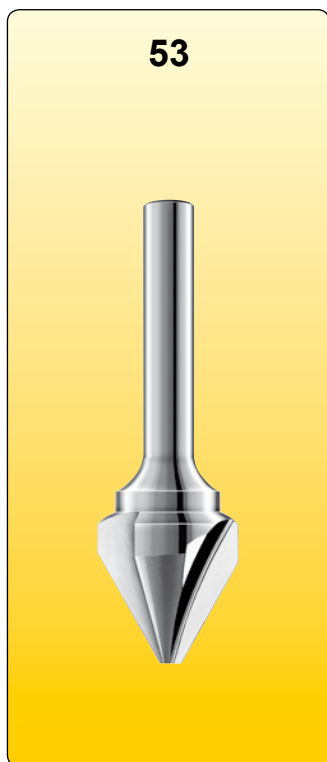

Einsatzgebiete / Range of application

A: Legierungen / Light alloys

A1.1-1.6 A2.1-2.7 A3.1-3.2 A4.1-4.2

B: Kunststoffe - Faserverstärkte Kunststoffe

B: Plastics - Reinforced plastic fibres

B1.1-1.3 B1.5-1.6 B2.1-2.4

C: Stahlwerkstoffe / Steels

C1.1-1.8 C2.1-2.3 C3.1 C4.1

D: Edelstahl / Stainless steel

D1.1-1.4

F: Gußeisen / Cast irons

F1.4-1.5 F2.1-2.4

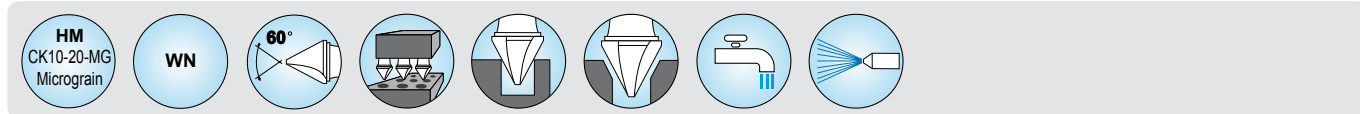
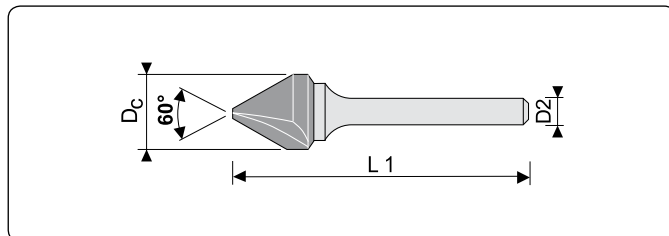

D _c	L1	D2 h6	53	53A
				Beschichtet / Coated
4,3	50	6	53.0406	53.0406A
6,3	51	6	53.0606	53.0606A
8,3	55	6	53.0806	53.0806A
10,4	56	6	53.1006	53.1006A
12,4	59	6	53.1206	53.1206A
12,4	59	8	53.1208	53.1208A
16,5	63	6	53.1606	53.1606A
16,5	63	8	53.1608	53.1608A
16,5	63	10	53.1610	53.1610A
20,5	67	6	53.2006	53.2006A
20,5	67	8	53.2008	53.2008A
20,5	67	10	53.2010	53.2010A
25,5	73	8	53.2508	53.2508A
25,5	73	10	53.2510	53.2510A
31,5	79	10	53.3110	53.3110A

Kegelsenker - 3 Schneiden - 90°

90° three flute countersink

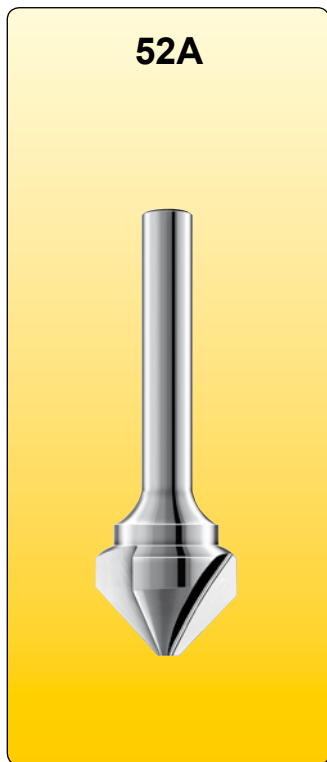
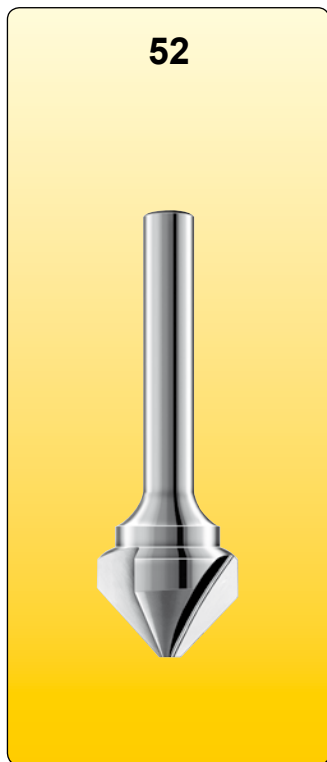

Einsatzgebiete / Range of application

A: Legierungen / Light alloys

A1.1-1.6 A2.1-2.7 A3.1-3.2 A4.1-4.2

B: Kunststoffe - Faserverstärkte Kunststoffe

B: *Plastics - Reinforced plastic fibres*

B1.1-1.3 B1.5-1.6 B2.1-2.4

C: Stahlwerkstoffe / Steels

C1.1-1.8 C2.1-2.3 C3.1 C4.1

D: Edelstahl / Stainless steel

D1.1-1.4

F: Gußeisen / Cast irons

F1.4-1.5 F2.1-2.4

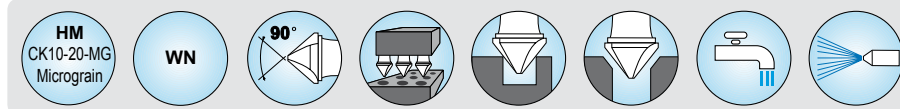
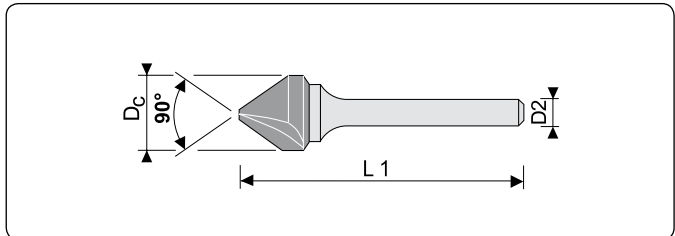

D _c	L1	D2 h6	52	52A
				Beschichtet / Coated
4,3	50	6	52.0406	52.0406A
6,3	51	6	52.0606	52.0606A
8,3	52	6	52.0806	52.0806A
10,4	53	6	52.1006	52.1006A
12,4	55	6	52.1206	52.1206A
12,4	55	8	52.1208	52.1208A
16,5	58	6	52.1606	52.1606A
16,5	58	8	52.1608	52.1608A
16,5	58	10	52.1610	52.1610A
20,5	61	6	52.2006	52.2006A
20,5	61	8	52.2008	52.2008A
20,5	61	10	52.2010	52.2010A
25,5	64	8	52.2508	52.2508A
25,5	64	10	52.2510	52.2510A
31,5	68	10	52.3110	52.3110A



A series of horizontal lines providing a writing area for the page.



Cerin[®] Spa

Via Enrico Fermi, 15 - 37010 AFFI (Verona) Italy
Tel. +39 045 7200 844 - Fax +39 045 7200 835
e-mail: cerin@cerin.it
www.cerin.it

45°33'53.28" N - 10°45'58.14" E